

Features

- Low drain-source on-resistance: $R_{DS(ON)}=0.035\Omega(\text{typ})$
- Very Low FOM ($R_{DS(on)} \times Q_g$)
- Extremely low switching loss
- 100% avalanche tested
- RoHS compliant

Key Performance Parameters



Parameter	Value	Unit
$V_{DS} @ T_{j,max}$	650	V
$R_{DS(ON),max}$	41	m Ω
I_D	80	A
$Q_{g,typ}$	133	nC
I_{DM}	240	A

Applications

- Switch Mode Power Supply (SMPS)
- Uninterruptible Power Supply (UPS)
- Power Factor Correction (PFC)

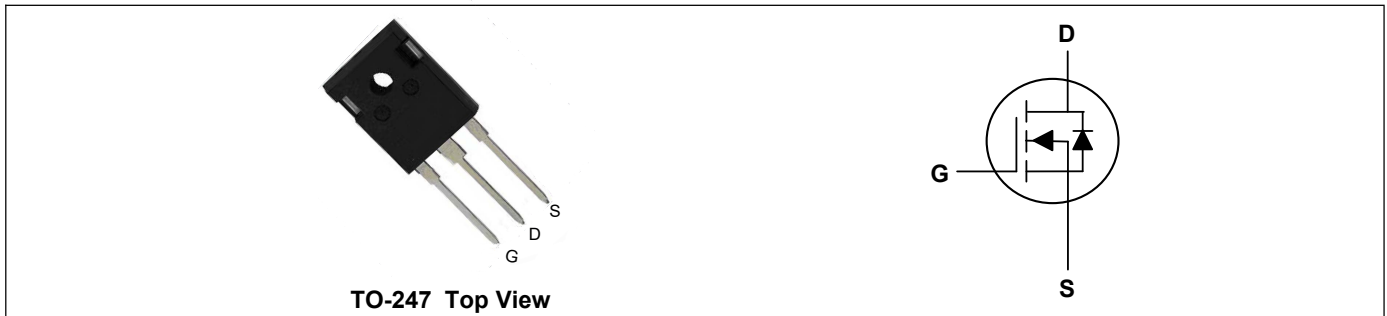

Absolute Maximum Ratings ($T_C=25^\circ\text{C}$, unless otherwise noted)

Parameter	Symbol	Value	Unit
Drain-Source Voltage	V_{DS}	650	V
Gate-Source Voltage	V_{GS}	± 30	V
Continuous Drain Current ¹	I_D	80	A
Pulsed Drain Current ²	I_{DM}	240	A
Single Pulse Avalanche Energy ⁴	EAS	720	mJ
Avalanche Current	I_{AS}	12	A
Repetitive Avalanche Energy	E_{AR}	3	mJ
MOSFET dv/dt ruggedness, $V_{DS} = 0 \dots 400\text{V}$	dv/dt	50	V/ns
Reverse diode dv/dt ³ $V_{DS}=0 \dots 400\text{V}$, $I_{SD} \leq I_D$		50	
Total Power Dissipation ($T_C=25^\circ\text{C}$)	P_D	481	W
Storage Temperature Range	T_{STG}	-55 to 150	$^\circ\text{C}$
Operating Junction Temperature Range	T_J	-55 to 150	$^\circ\text{C}$

Thermal Characteristics

Parameter	Symbol	Value	Unit
Thermal Resistance Junction-Ambient (Max)	$R_{\theta JA}$	62	$^\circ\text{C/W}$
Thermal Resistance Junction-Case (Max)	$R_{\theta JC}$	0.26	$^\circ\text{C/W}$

Electrical Characteristics ($T_J=25^\circ\text{C}$, unless otherwise noted)

Parameter	Symbol	Conditions	Min	Typ	Max	Unit
Drain-Source Breakdown Voltage	BV_{DSS}	$V_{GS}=0V, I_D=250\mu A$	650	---	---	V
Static Drain-Source On-Resistance	$R_{DS(ON)}$	$V_{GS}=10V, I_D=36A$	---	35	41	m Ω
Gate Threshold Voltage	$V_{GS(th)}$	$V_{GS}=V_{DS}, I_D=250\mu A$	2.5	---	4.5	V
Drain-Source Leakage Current	I_{DSS}	$V_{DS}=650V, V_{GS}=0V, T_J=25^\circ\text{C}$	---	---	5	μA
		$V_{DS}=650V, V_{GS}=0V, T_J=150^\circ\text{C}$	---	---	1000	μA
Gate-Source Leakage Current	I_{GSS}	$V_{GS}=\pm 30V, V_{DS}=0V$	---	---	± 100	nA
Gate Resistance	R_g	$V_{DS}=0V, V_{GS}=0V, f=1\text{MHz}$	---	13	---	Ω
Total Gate Charge	Q_g	$V_{DD}=520V, V_{GS}=10V, I_D=72A$	---	133	---	nC
Gate-Source Charge	Q_{gs}		---	27	---	
Gate-Drain Charge	Q_{gd}		---	41	---	
Turn-On Delay Time	$T_{d(on)}$	$V_{DD}=400V, R_G=1.9\Omega, I_D=44.4A, V_{GS}=13V$	---	22	---	ns
Rise Time	T_r		---	10	---	
Turn-Off Delay Time	$T_{d(off)}$		---	120	---	
Fall Time	T_f		---	8	---	
Input Capacitance	C_{iss}	$V_{DS}=50V, V_{GS}=0V, f=1\text{MHz}$	---	5960	---	pF
Output Capacitance	C_{oss}		---	490	---	
Reverse Transfer Capacitance	C_{rss}		---	30	---	

Drain-Source Diode Characteristics

Parameter	Symbol	Conditions	Min	Typ	Max	Unit
Continuous Source Current	I_S	$T_C=25^\circ\text{C}$	---	---	80	A
Pulsed Source Current	I_{SM}		---	---	240	A
Diode Forward Voltage	V_{SD}	$V_G=0V, I_S=50A, T_J=25^\circ\text{C}$	---	0.8	1.2	V
Reverse Recovery Time	t_{rr}	$V_R=400V, I_F=44.4A, di_F/dt=100A/\mu s$	---	390	---	ns
Reverse Recovery Charge	Q_{rr}		---	9	---	μC
Peak Reverse Recovery Current	I_{rrm}		---	35	---	A

Note:

- Limited by $T_{J,max}$. Maximum Duty Cycle $D = 0.50$
- Pulse width t_p limited by $T_{J,max}$
- Identical low side and high side switch with identical R_G
- $V_{DD}=50V, R_G=25\Omega, I_{AS}=15A$, Starting $T_J=25^\circ\text{C}$

Typical Characteristics

Figure 1. Output Characteristics

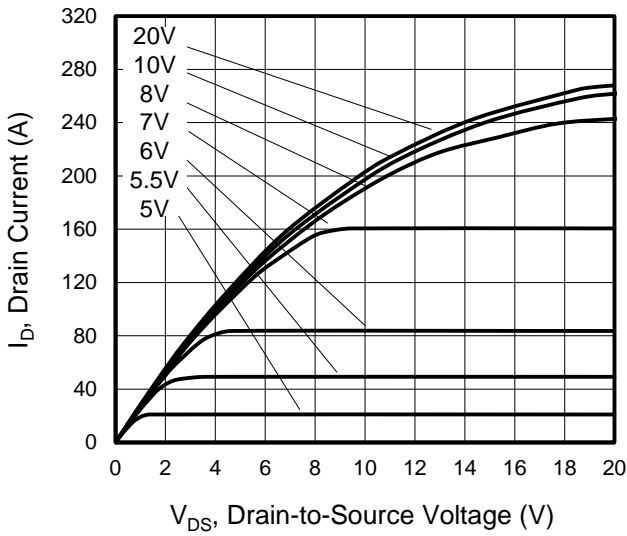

Figure 2. Transfer Characteristics

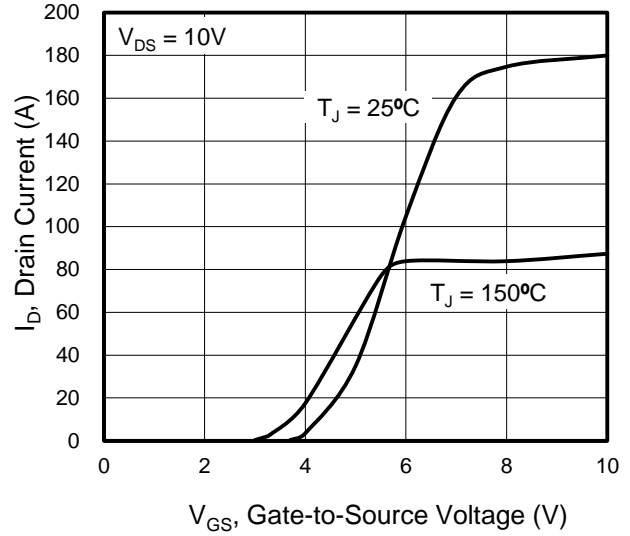

Figure 3. On-Resistance vs. Drain Current

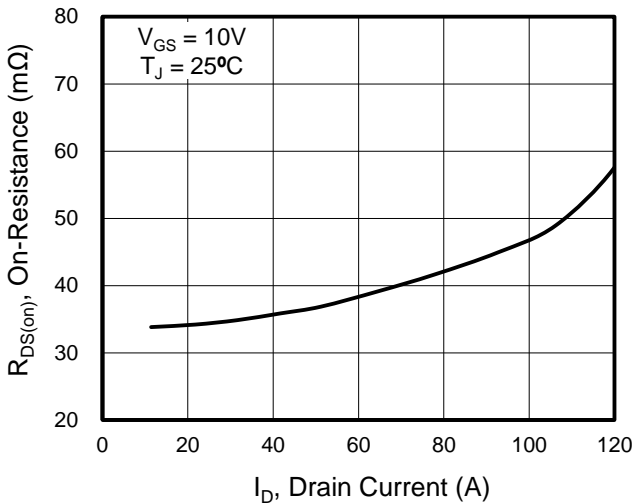

Figure 4. Capacitance

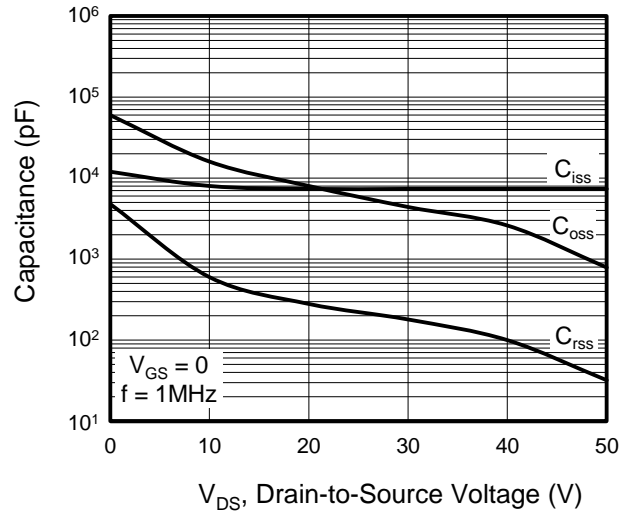

Figure 5. Gate Charge

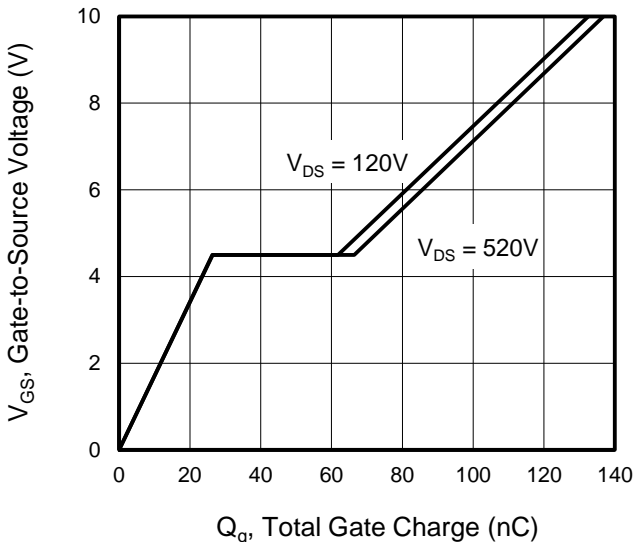

Figure 6. Body Diode Forward Voltage

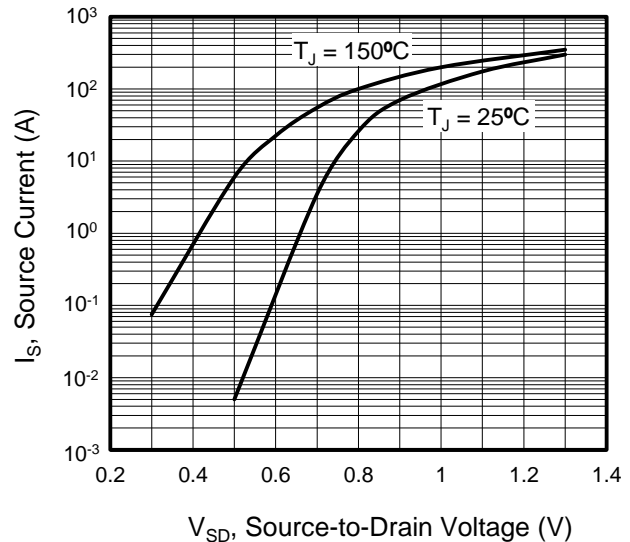

Figure 7. On-Resistance vs. Temperature

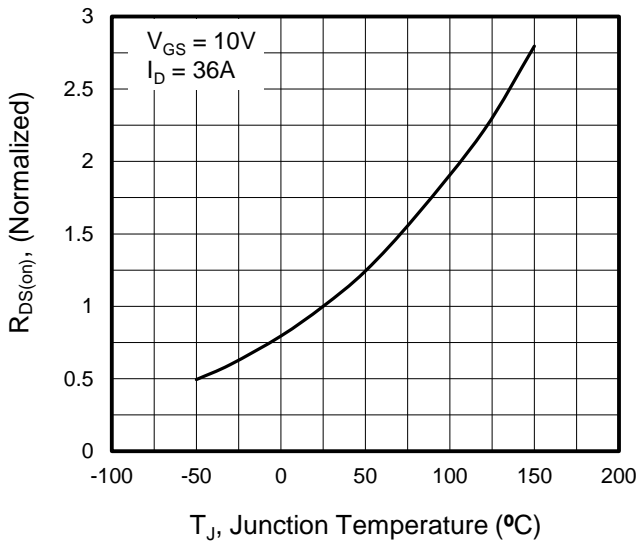

Figure 8. Threshold Voltage vs. Temperature

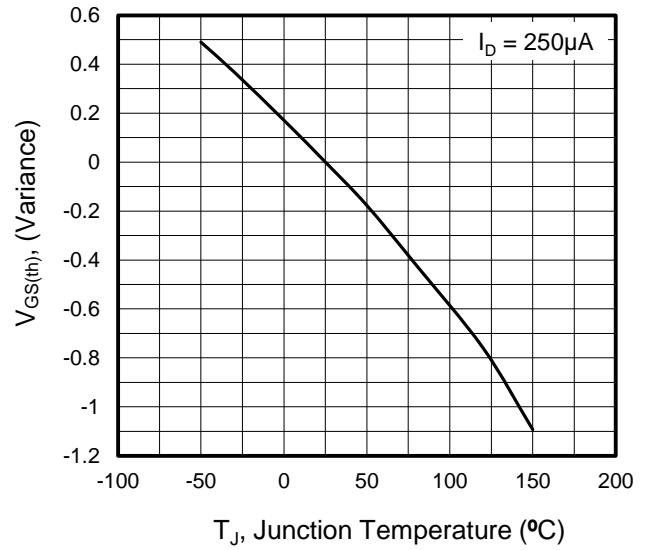
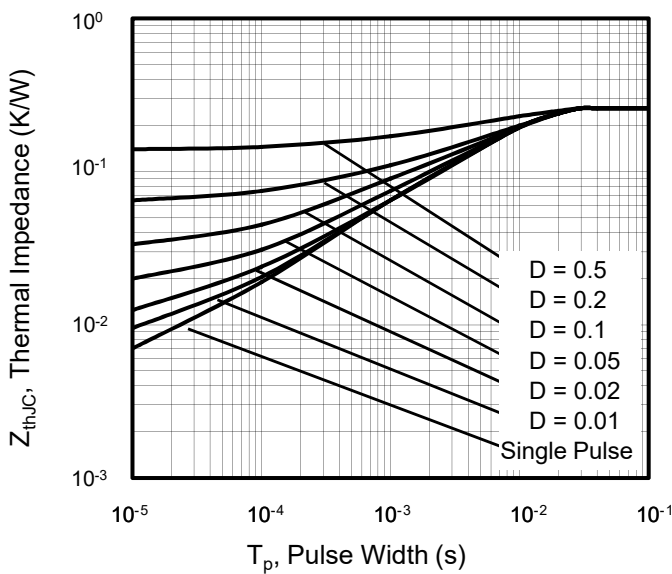
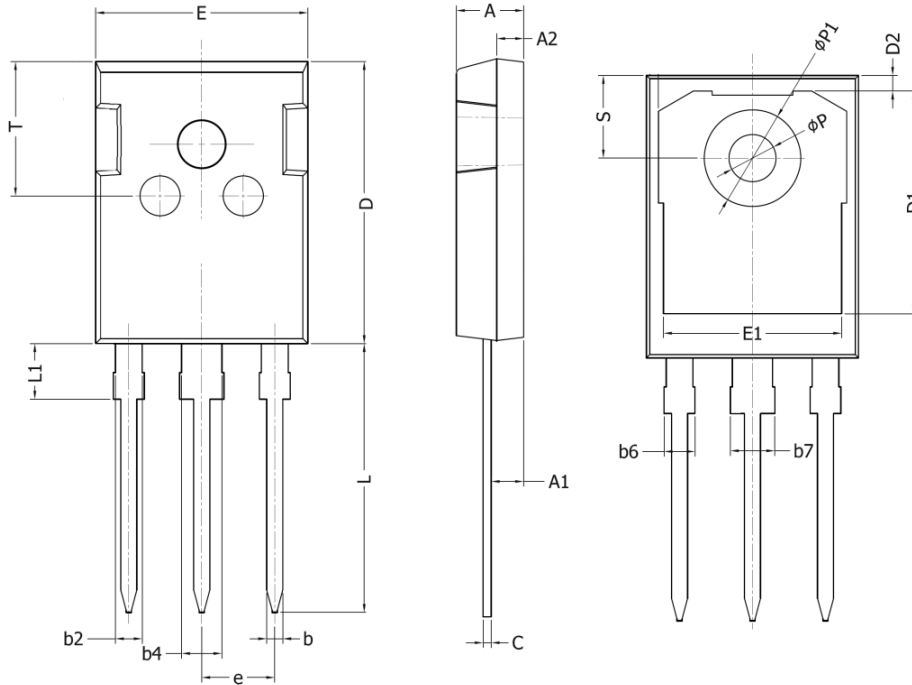

Figure 9. Transient Thermal Impedance



TO-247 Package Outline Dimensions



Symbol	Dimensions In Millimeters	
	Min.	Max.
A	4.90	5.20
A1	2.31	2.51
A2	1.9	2.1
b	1.16	1.26
b2	1.96	2.06
b4	2.96	3.06
b6	-	2.25
b7	-	3.25
C	0.59	0.66
D	20.90	21.20
D1	16.25	16.85
D2	1.05	1.35
E	15.75	16.10
E1	13.00	13.60
e	5.436 BSC	
L	19.80	20.20
L1	-	4.30
P	3.40	3.60
P1	7.00	7.40
S	6.05	6.25
T	9.80	10.20