

**Features**

- Advanced high cell density Trench technology
- Super Low Gate Charge
- Excellent CdV/dt effect decline
- Green Device Available

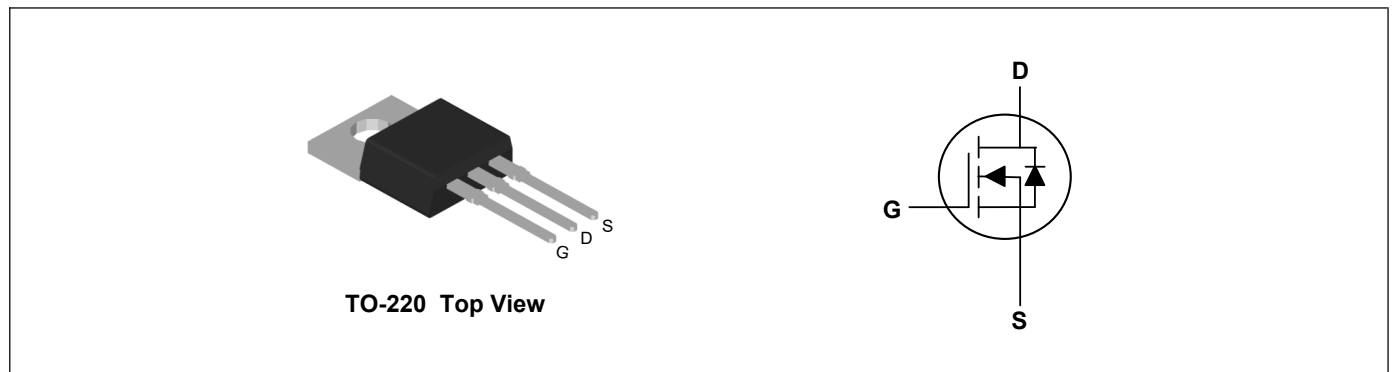
**Product Summary**



$V_{DS}$	120	V
$I_D$	60	A
$R_{DS(ON)}$ (at $V_{GS}=10V$ )	11	m $\Omega$

**Applications**

- High Frequency Point-of-Load, Synchronous Buck Converter
- Networking DC-DC Power System
- Load Switch



**Absolute Maximum Ratings( $T_C=25^{\circ}C$ , unless otherwise noted)**

Parameter	Symbol	Rating	Units
Drain-Source Voltage	$V_{DS}$	120	V
Gate-Source Voltage	$V_{GS}$	$\pm 20$	V
Continuous Drain Current	$I_D$	60	A
Continuous Drain Current	$I_{D@T_C=100^{\circ}C}$	42.4	A
Pulsed Drain Current	$I_{DM}$	240	A
Single Pulse Avalanche Energy <sup>3</sup>	EAS	290	mJ
Total Power Dissipation	$P_D$	105	W
Storage Temperature Range	$T_{STG}$	-55 to 175	$^{\circ}C$
Operating Junction Temperature Range	$T_J$	-55 to 175	$^{\circ}C$

**Thermal Characteristics**

Parameter	Symbol	Typ	Max	Unit
Thermal Resistance Junction-Case <sup>1</sup>	$R_{\theta JC}$	---	1.4	$^{\circ}C/W$

**Electrical Characteristics ( $T_J=25^{\circ}\text{C}$ , unless otherwise noted)**

Parameter	Symbol	Conditions	Min	Typ	Max	Unit
Drain-Source Breakdown Voltage	$BV_{DSS}$	$V_{GS}=0V, I_D=250\mu A$	120	---	---	V
Static Drain-Source On-Resistance	$R_{DS(ON)}$	$V_{GS}=10V, I_D=30A$	---	10	11	m $\Omega$
Gate Threshold Voltage	$V_{GS(th)}$	$V_{GS}=V_{DS}, I_D=250\mu A$	1.0	1.8	2.5	V
Drain-Source Leakage Current	$I_{DSS}$	$V_{DS}=120V, V_{GS}=0V, T_J=25^{\circ}\text{C}$	---	---	1	$\mu A$
Gate-Source Leakage Current	$I_{GSS}$	$V_{GS}=\pm 20V, V_{DS}=0V$	---	---	$\pm 100$	nA
Forward Transconductance	$g_{fs}$	$V_{DS}=5V, I_D=30A$	---	40	---	S
Total Gate Charge	$Q_g$	$V_{DS}=60V, V_{GS}=10V, I_D=30A$	---	37	---	nC
Gate-Source Charge	$Q_{gs}$		---	14	---	
Gate-Drain Charge	$Q_{gd}$		---	8	---	
Turn-On Delay Time	$T_{d(on)}$	$V_{DD}=50V, I_D=30A, V_{GS}=10V, R_G=3\Omega$	---	11	---	ns
Rise Time	$T_r$		---	7.5	---	
Turn-Off Delay Time	$T_{d(off)}$		---	26	---	
Fall Time	$T_f$		---	4	---	
Input Capacitance	$C_{iss}$	$V_{DS}=60V, V_{GS}=0V, f=1\text{MHz}$	---	2500	---	pF
Output Capacitance	$C_{oss}$		---	273	---	
Reverse Transfer Capacitance	$C_{rss}$		---	27	---	

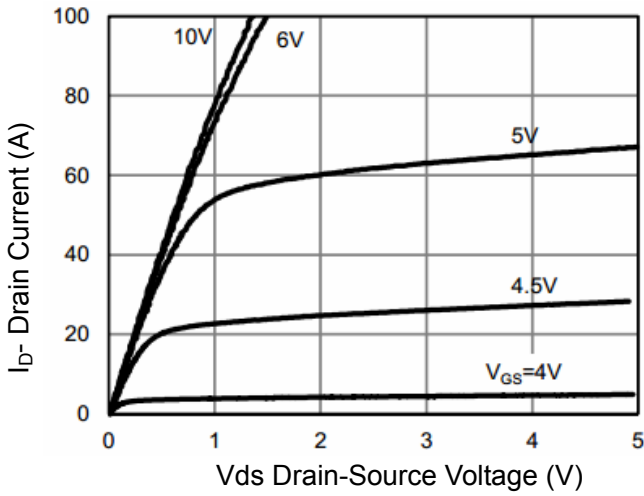
**Drain-Source Diode Characteristics**

Parameter	Symbol	Conditions	Min	Typ	Max	Unit
Continuous Source Current <sup>2</sup>	$I_S$		---	---	60	A
Diode Forward Voltage <sup>1</sup>	$V_{SD}$	$V_{GS}=0V, I_F=60A, T_J=25^{\circ}\text{C}$	---	---	1.2	V
Reverse Recovery Time	$t_{rr}$	$I_F=I_S, di/dt=100A/\mu s, T_J=25^{\circ}\text{C}$	---	58	---	nS
Reverse Recovery Charge	$Q_{rr}$		---	149	---	nC

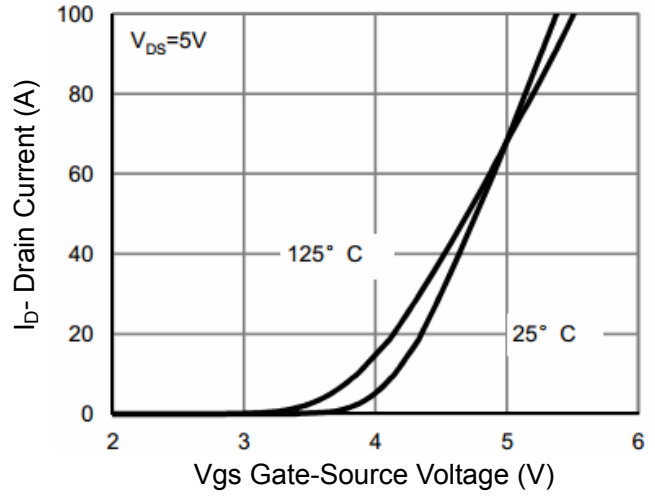
**Note:**

1. The data tested by surface mounted on a 1 inch<sup>2</sup> FR-4 board with 2OZ copper.
2. The data tested by pulsed, pulse width  $\leq 300\mu s$ , duty cycle  $\leq 2\%$
3. ESD condition:  $T_J=25^{\circ}\text{C}, V_{DD}=50V, V_{GS}=10V, L=0.5\text{mH}, R_G=25\Omega$

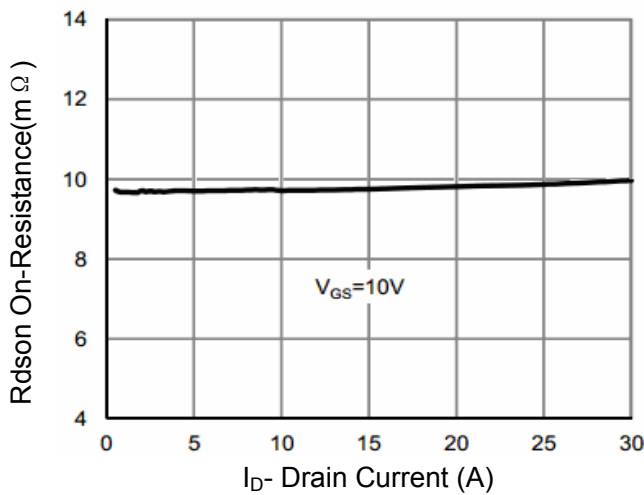
**Typical Characteristics**



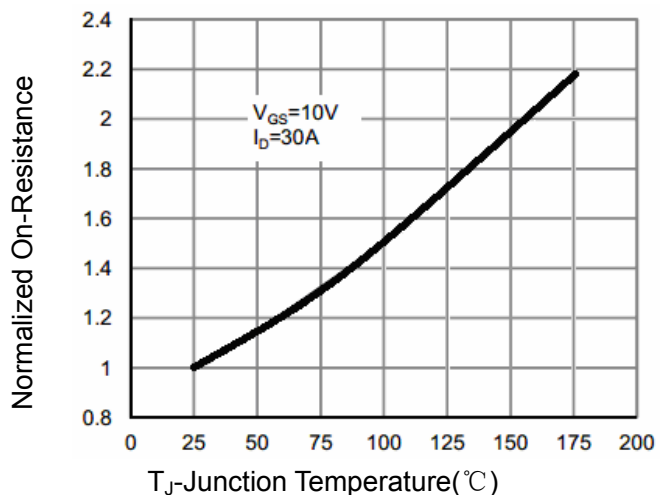
**Figure 1 Output Characteristics**



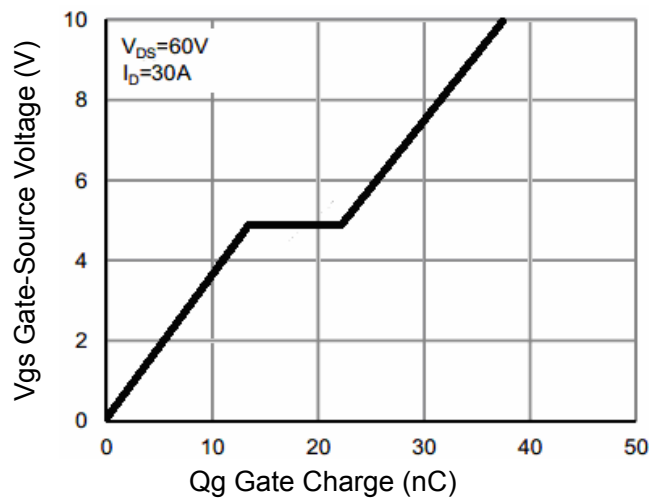
**Figure 2 Transfer Characteristics**



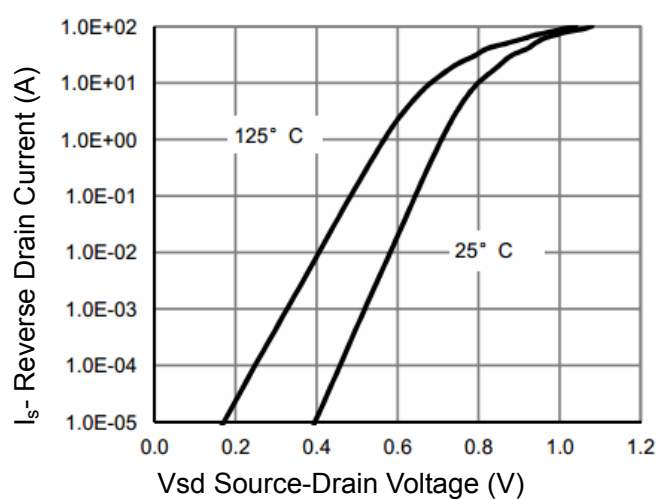
**Figure 3 Rdson- Drain Current**



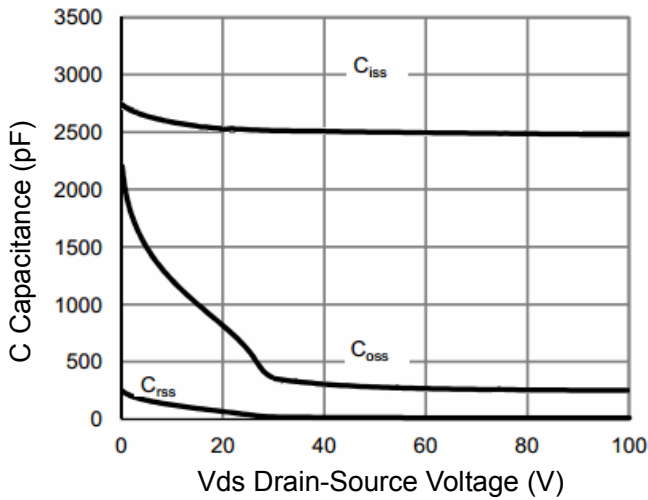
**Figure 4 Rdson-Junction Temperature**



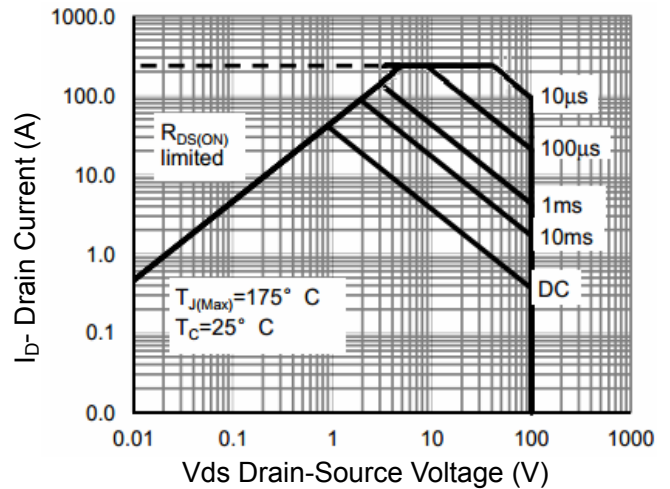
**Figure 5 Gate Charge**



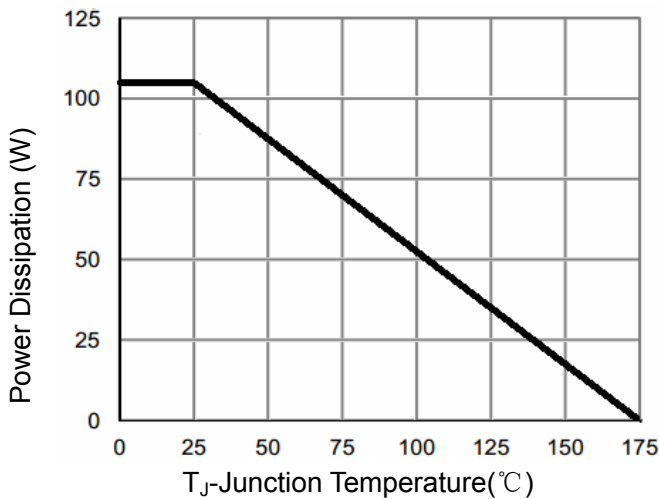
**Figure 6 Source- Drain Diode Forward**



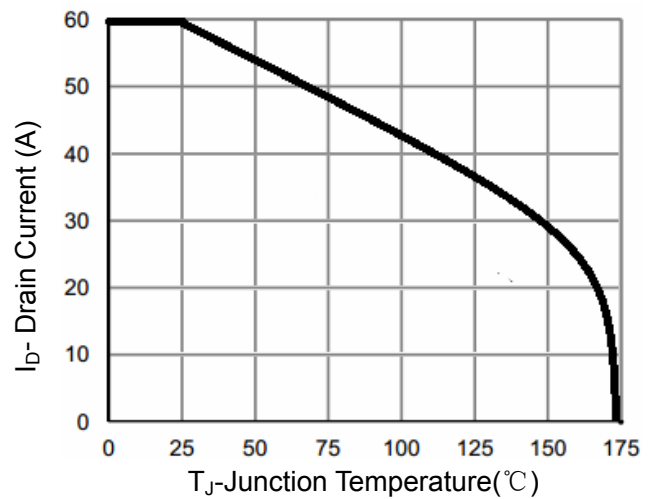
**Figure 7 Capacitance vs Vds**



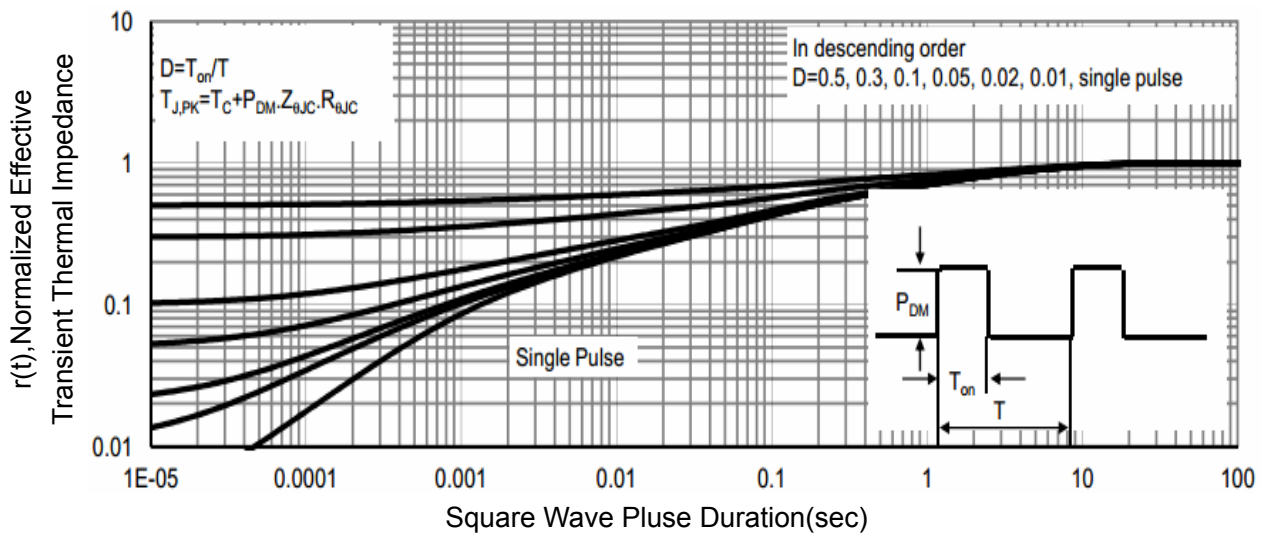
**Figure 8 Safe Operation Area**



**Figure 9 Power De-rating**

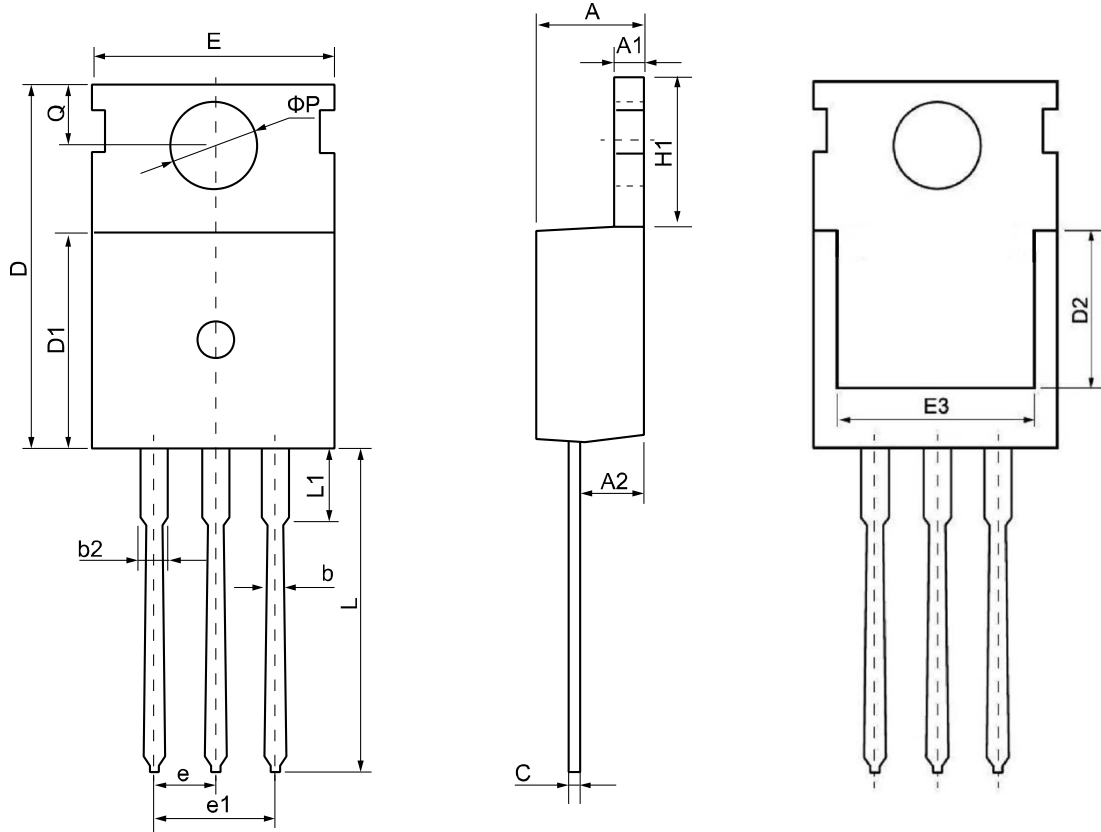


**Figure 10 Current De-rating**



**Figure 11 Normalized Maximum Transient Thermal Impedance**

**TO-220 Package Outline Dimensions**



Symbol	Dimensions (unit:mm)			Symbol	Dimensions (unit:mm)		
	Min	Typ	Max		Min	Typ	Max
<b>A</b>	4.30	4.55	4.75	<b>E</b>	9.65	10.00	10.25
<b>A1</b>	1.15	1.30	1.45	<b>E3</b>	7.00	--	--
<b>A2</b>	2.20	2.40	2.60	<b>e</b>	2.54 BSC		
<b>b</b>	0.70	0.80	0.95	<b>e1</b>	5.08 BSC		
<b>b2</b>	1.17	1.27	1.47	<b>H1</b>	6.30	6.50	6.80
<b>c</b>	0.40	0.50	0.65	<b>L</b>	12.70	13.50	14.10
<b>D</b>	15.30	15.60	15.90	<b>L1</b>	--	3.20	3.95
<b>D1</b>	8.90	9.10	9.35	<b>φP</b>	3.40	3.60	3.80
<b>D2</b>	5.50	--	--	<b>Q</b>	2.60	2.80	3.00