

Features

- Advanced high cell density Trench technology
- Super Low Gate Charge
- Excellent CdV/dt effect decline
- 100% EAS Guaranteed
- Green Device Available

Product Summary



V_{DS}	200	V
I_D	18	A
$R_{DS(ON)}$ (at $V_{GS}=10V$)	170	m Ω
$R_{DS(ON)}$ (at $V_{GS}=4.5V$)	180	m Ω

Applications

- High Frequency Point-of-Load, Synchronous Buck Converter
- Networking DC-DC Power System
- Load Switch, LCD/LED Back light

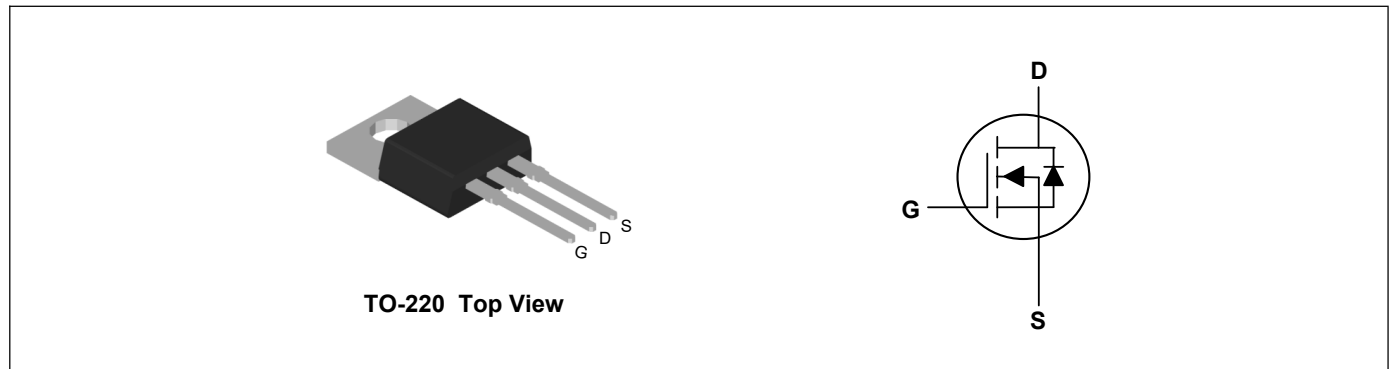

Absolute Maximum Ratings ($T_C=25^{\circ}C$, unless otherwise noted)

Parameter	Symbol	Rating	Units
Drain-Source Voltage	V_{DS}	200	V
Gate-Source Voltage	V_{GS}	± 20	V
Continuous Drain Current, V_{GS} @ 10V ¹	$I_D@T_C=25^{\circ}C$	18	A
Continuous Drain Current, V_{GS} @ 10V ¹	$I_D@T_C=100^{\circ}C$	11.7	A
Pulsed Drain Current ²	I_{DM}	40	A
Single Pulse Avalanche Energy ³	EAS	15	mJ
Avalanche Current	I_{AS}	10	A
Total Power Dissipation ⁴	$P_D@T_C=25^{\circ}C$	83	W
Storage Temperature Range	T_{STG}	-55 to 150	$^{\circ}C$
Operating Junction Temperature Range	T_J	-55 to 150	$^{\circ}C$

Thermal Characteristics

Parameter	Symbol	Typ	Max	Unit
Thermal Resistance Junction-Ambient ¹	$R_{\theta JA}$	---	60	$^{\circ}C/W$
Thermal Resistance Junction-Case ¹	$R_{\theta JC}$	---	1.5	$^{\circ}C/W$

Electrical Characteristics (T_J=25°C, unless otherwise noted)

Parameter	Symbol	Conditions	Min	Typ	Max	Unit
Drain-Source Breakdown Voltage	BV _{DSS}	V _{GS} =0V, I _D =250μA	200	---	---	V
Static Drain-Source On-Resistance ²	R _{DS(ON)}	V _{GS} =10V, I _D =9A	---	---	170	mΩ
		V _{GS} =4.5V, I _D =9A	---	---	180	mΩ
Gate Threshold Voltage	V _{GS(th)}	V _{GS} =V _{DS} , I _D =250μA	1.2	1.8	2.5	V
Drain-Source Leakage Current	I _{DSS}	V _{DS} =160V, V _{GS} =0V, T _J =25°C	---	---	1	μA
		V _{DS} =160V, V _{GS} =0V, T _J =55°C	---	---	5	μA
Gate-Source Leakage Current	I _{GSS}	V _{GS} =±20V, V _{DS} =0V	---	---	±100	nA
Forward Transconductance	g _{fs}	V _{DS} =5V, I _D =9A	---	22	---	S
Gate Resistance	R _g	V _{DS} =0V, V _{GS} =0V, f=1MHz	---	2	---	Ω
Total Gate Charge	Q _g	V _{DS} =80V, V _{GS} =10V, I _D =9A	---	45	---	nC
Gate-Source Charge	Q _{gs}		---	9	---	
Gate-Drain Charge	Q _{gd}		---	10.5	---	
Turn-On Delay Time	T _{d(on)}	V _{DD} =50V, V _{GS} =10V, R _G =3.3Ω, I _D =9A	---	13	---	ns
Rise Time	T _r		---	8.2	---	
Turn-Off Delay Time	T _{d(off)}		---	25	---	
Fall Time	T _f		---	11	---	
Input Capacitance	C _{iss}	V _{DS} =25V, V _{GS} =0V, f=1MHz	---	2047	---	pF
Output Capacitance	C _{oss}		---	109	---	
Reverse Transfer Capacitance	C _{rss}		---	70	---	

Drain-Source Diode Characteristics

Parameter	Symbol	Conditions	Min	Typ	Max	Unit
Continuous Source Current ^{1,5}	I _S	V _G =V _D =0V, Force Current	---	---	18	A
Pulsed Source Current ^{2,5}	I _{SM}		---	---	40	A
Diode Forward Voltage ²	V _{SD}	V _{GS} =0V, I _S =1A, T _J =25°C	---	---	1.2	V
Reverse Recovery Time	t _{rr}	I _F =10A, di/dt=100A/μs, T _J =25°C	---	37	---	nS
Reverse Recovery Charge	Q _{rr}		---	103	---	nC

Note:

- The data tested by surface mounted on a 1 inch² FR-4 board with 2OZ copper.
- The data tested by pulsed, pulse width ≤ 300μs, duty cycle ≤ 2%
- The EAS data shows Max. rating. The test condition is V_{DD}=25V, V_{GS}=10V, L=0.3mH
- The power dissipation is limited by 150°C junction temperature
- The data is theoretically the same as I_D and I_{DM}, in real applications, should be limited by total power dissipation.

Typical Characteristics

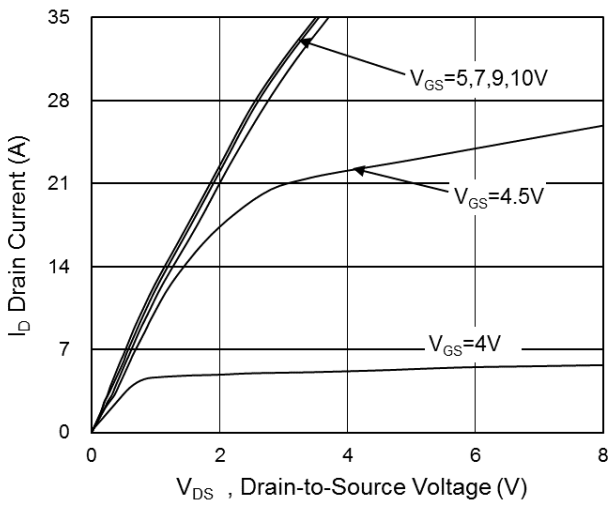

Fig.1 Typical Output Characteristics

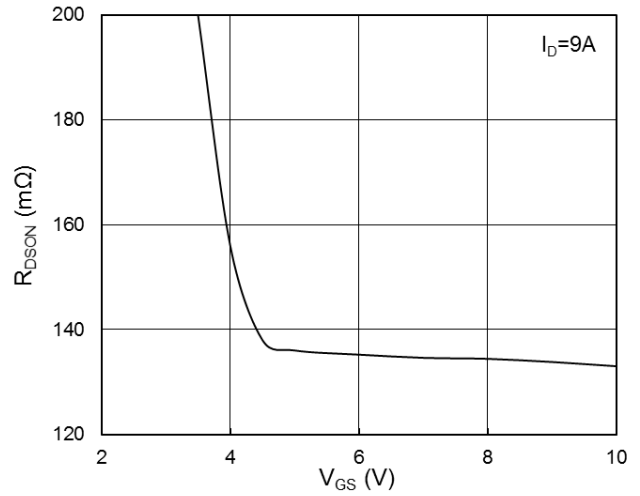

Fig.2 On-Resistance vs. Gate-Source

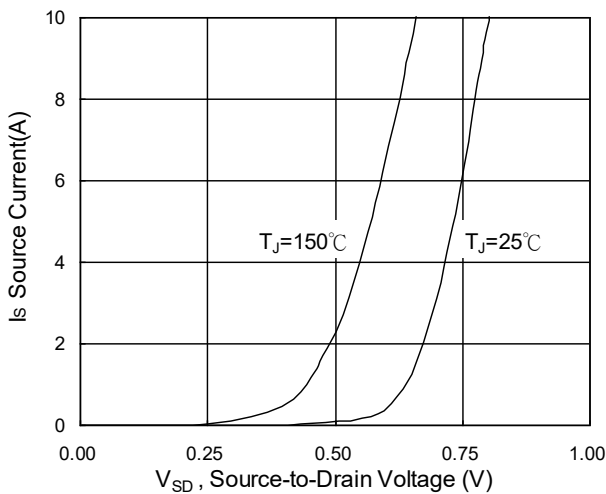

Fig.3 Forward Characteristics Of Reverse

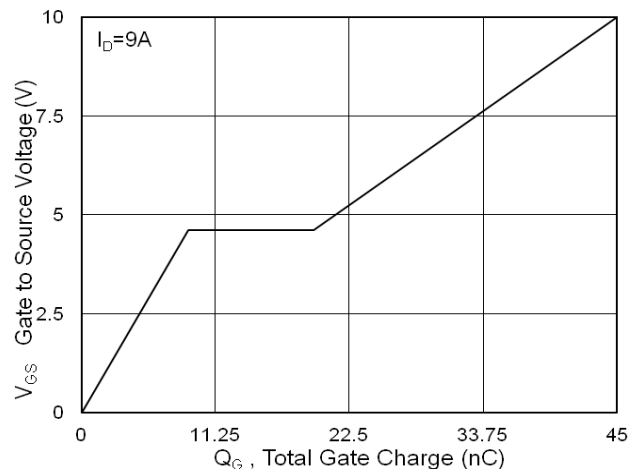

Fig.4 Gate-Charge Characteristics

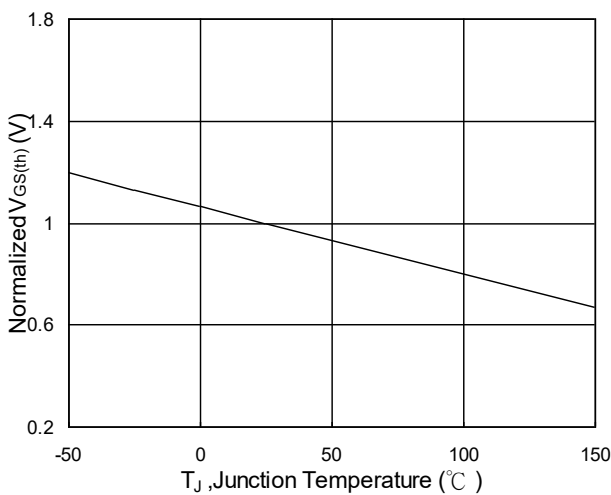

Fig.5 Normalized $V_{GS(th)}$ vs. T_J

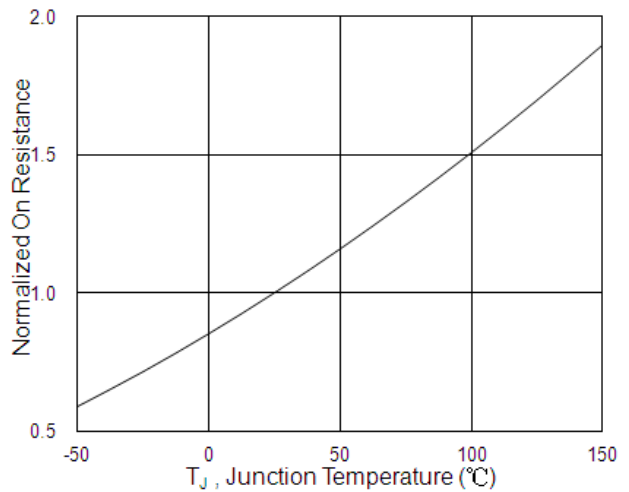

Fig.6 Normalized $R_{DS(on)}$ vs. T_J

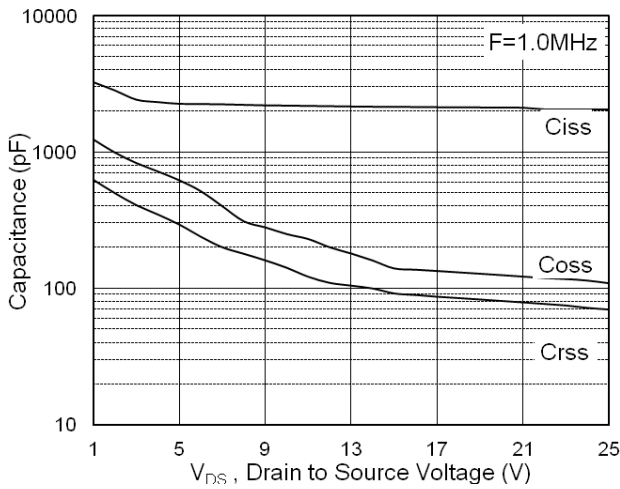

Fig.7 Capacitance

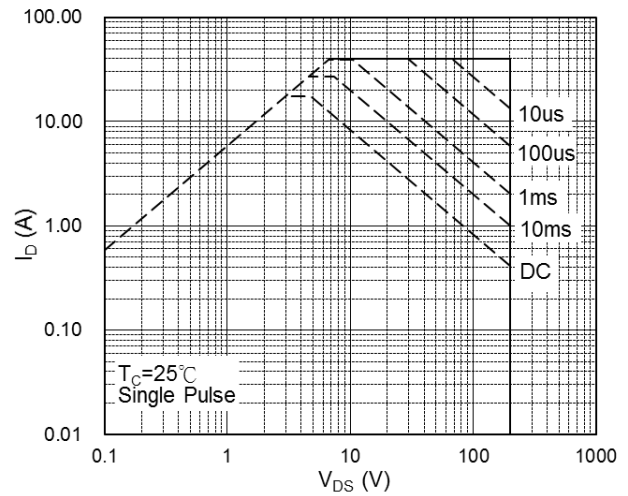

Fig.8 Safe Operating Area

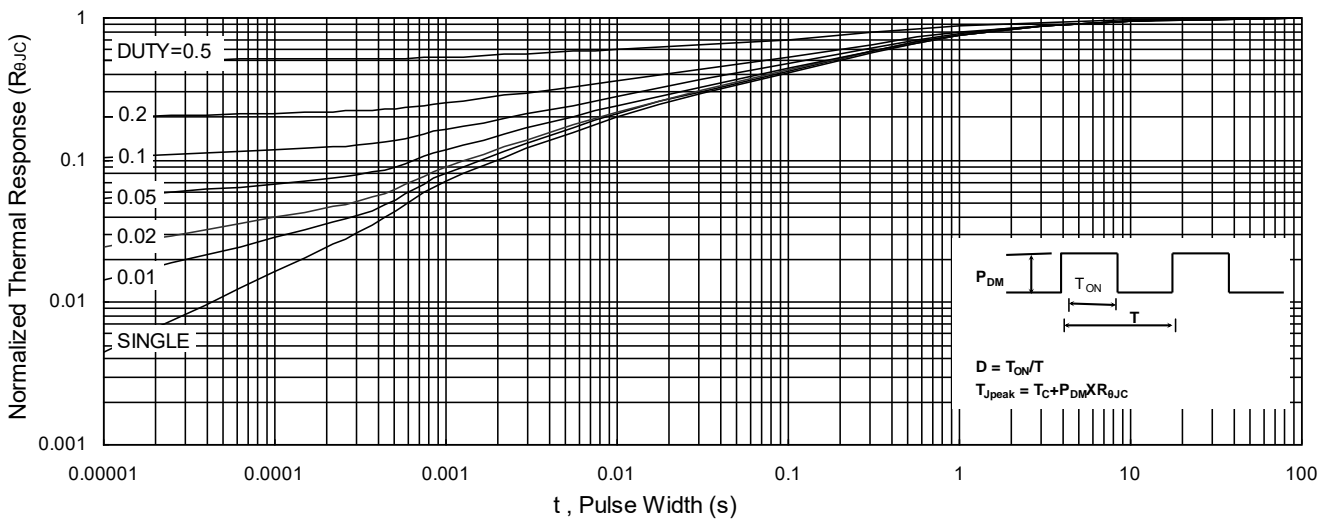

Fig.9 Normalized Maximum Transient Thermal Impedance

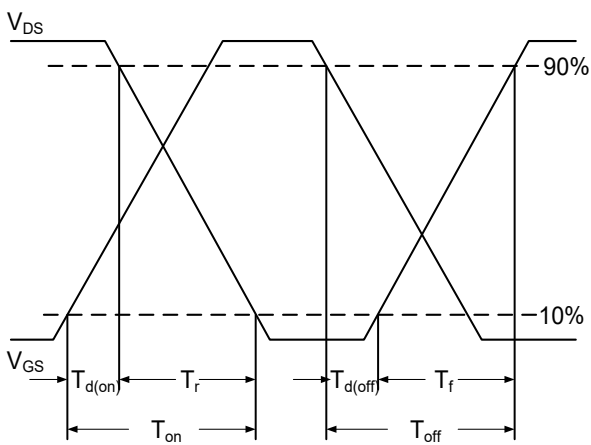

Fig.10 Switching Time Waveform

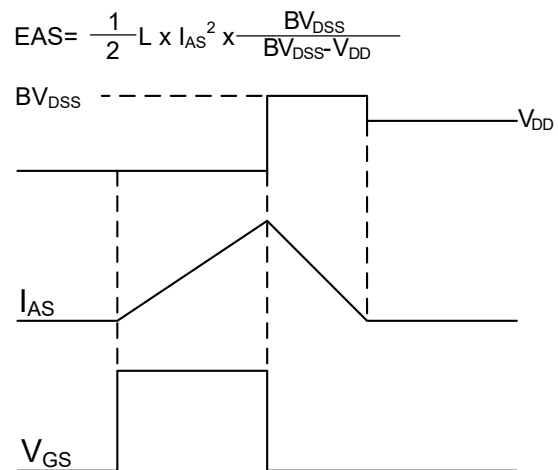
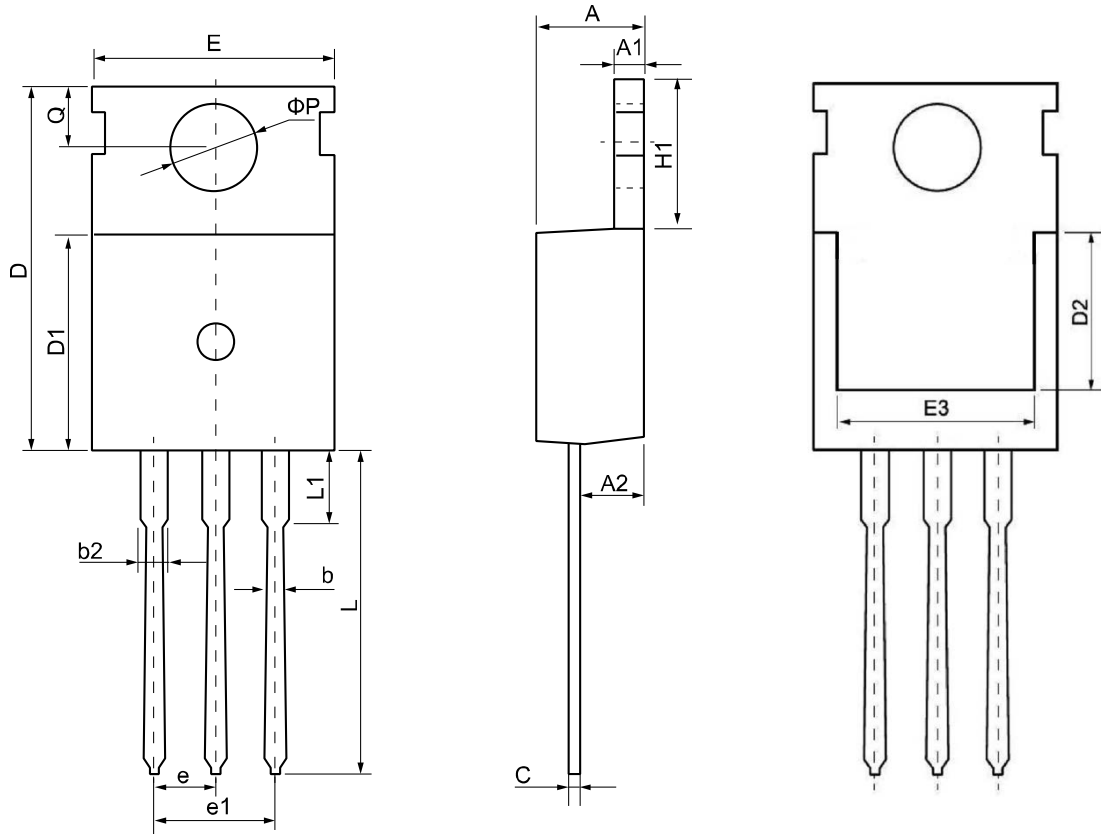

Fig.11 Unclamped Inductive Switching Waveform

TO-220 Package Outline Dimensions



Symbol	Dimensions (unit:mm)			Symbol	Dimensions (unit:mm)		
	Min	Typ	Max		Min	Typ	Max
A	4.30	4.55	4.75	E	9.65	10.00	10.25
A1	1.15	1.30	1.45	E3	7.00	--	--
A2	2.20	2.40	2.60	e	2.54 BSC		
b	0.70	0.80	0.95	e1	5.08 BSC		
b2	1.17	1.27	1.47	H1	6.30	6.50	6.80
c	0.40	0.50	0.65	L	12.70	13.50	14.10
D	15.30	15.60	15.90	L1	--	3.20	3.95
D1	8.90	9.10	9.35	φP	3.40	3.60	3.80
D2	5.50	--	--	Q	2.60	2.80	3.00