

Features

- Advanced Shield Gate Trench technology
- Super Low Gate Charge
- High-Speed Switching
- 100% EAS Guaranteed
- Green Device Available

Product Summary



V_{DS}	100	V
I_D	102	A
$R_{DS(ON)}$ (at $V_{GS}=10V$)	5.8	m Ω
$R_{DS(ON)}$ (at $V_{GS}=4.5V$)	8.0	m Ω

Applications

- High Frequency Point-of-Load, Synchronous Buck Converter
- Networking DC-DC Power System
- Load Switch

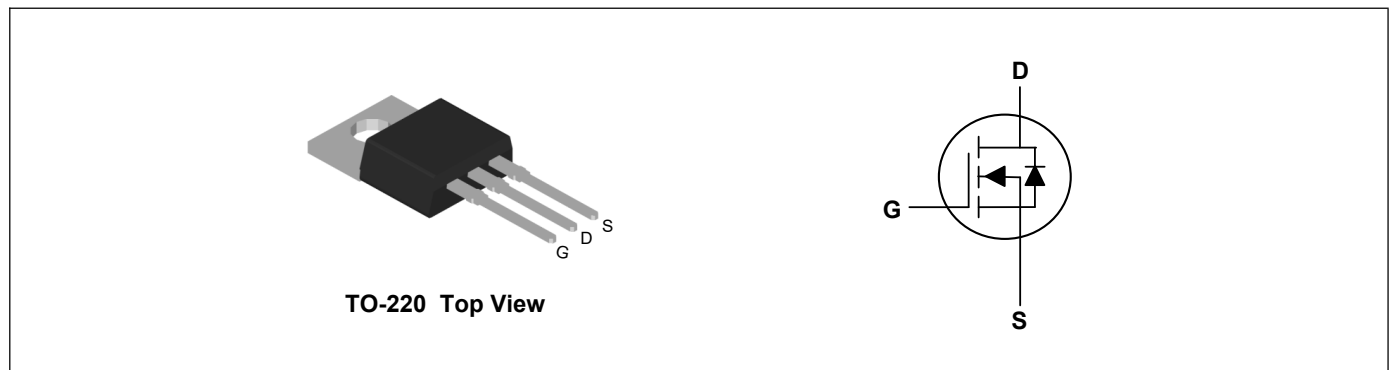

Absolute Maximum Ratings($T_C=25^\circ C$, unless otherwise noted)

Parameter	Symbol	Rating	Units
Drain-Source Voltage	V_{DS}	100	V
Gate-Source Voltage	V_{GS}	± 20	V
Continuous Drain Current ¹	I_D	102	A
Continuous Drain Current ¹	I_D	65	A
Pulsed Drain Current ²	I_{DM}	122	A
Single Pulse Avalanche Energy ³	E_{AS}	16	mJ
Avalanche Current	I_{AS}	18	A
Total Power Dissipation ⁴	P_D	125	W
Total Power Dissipation ⁴	P_D	50	W
Storage Temperature Range	T_{STG}	-55 to 150	$^\circ C$
Operating Junction Temperature Range	T_J	-55 to 150	$^\circ C$

Thermal Characteristics

Parameter	Symbol	Typ	Max	Unit
Thermal Resistance Junction-Ambient ¹	$R_{\theta JA}$	---	62.5	$^\circ C/W$
Thermal Resistance Junction-Case ¹	$R_{\theta JC}$	---	1	$^\circ C/W$

Electrical Characteristics (T_J=25°C, unless otherwise noted)

Parameter	Symbol	Conditions	Min	Typ	Max	Unit
Drain-Source Breakdown Voltage	BV _{DSS}	V _{GS} =0V, I _D =250uA	100	---	---	V
Static Drain-Source On-Resistance ²	R _{DS(ON)}	V _{GS} =10V, I _D =20A	---	5.1	5.8	mΩ
		V _{GS} =4.5V, I _D =20A	---	7.0	8.0	mΩ
Gate Threshold Voltage	V _{GS(th)}	V _{GS} =V _{DS} , I _D =250uA	2	3	4	V
Drain-Source Leakage Current	I _{DSS}	V _{DS} =80V, V _{GS} =0V	---	---	1	uA
Gate-Source Leakage Current	I _{GSS}	V _{GS} =±20V, V _{DS} =0V	---	---	±100	nA
Forward Transconductance	g _{fs}	V _{DS} =5V, I _D =10A	---	3.2	---	S
Gate Resistance	R _g	V _{DS} =0V, V _{GS} =0V, f=1MHz	---	1.8	---	Ω
Total Gate Charge	Q _g	V _{DS} =50V, V _{GS} =10V, I _D =20A	---	60	---	nC
Gate-Source Charge	Q _{gs}		---	8.2	---	
Gate-Drain Charge	Q _{gd}		---	16.5	---	
Turn-On Delay Time	T _{d(on)}	V _{DS} =50V, V _{GS} =10V, R _G =3Ω, I _D =1A	---	11	---	ns
Rise Time	T _r		---	21	---	
Turn-Off Delay Time	T _{d(off)}		---	43	---	
Fall Time	T _f		---	26	---	
Input Capacitance	C _{iss}	V _{DS} =50V, V _{GS} =0V, f=1MHz	---	3010	---	pF
Output Capacitance	C _{oss}		---	540	---	
Reverse Transfer Capacitance	C _{rss}		---	21	---	

Drain-Source Diode Characteristics

Parameter	Symbol	Conditions	Min	Typ	Max	Unit
Diode Forward Voltage ²	V _{SD}	V _{GS} =0V, I _S =20A, T _J =25°C	---	0.85	1.3	V
Reverse Recovery Time	t _{rr}	I _F =20A, V _R =50V di/dt=100A/μs, T _J =25°C	---	55	---	nS
Reverse Recovery Charge	Q _{rr}		---	109	---	nC

Note:

- 1.The data tested by surface mounted on a 1 inch² FR-4 board with 2OZ copper.
- 2.The data tested by pulsed, pulse width ≤ 300us, duty cycle ≤ 2%
- 3.The EAS data shows Max. rating. The test condition is V_{DD}=50V, V_{GS}=10V, L=0.1mH
- 4.The power dissipation is limited by 150°C junction temperature

Typical Characteristics

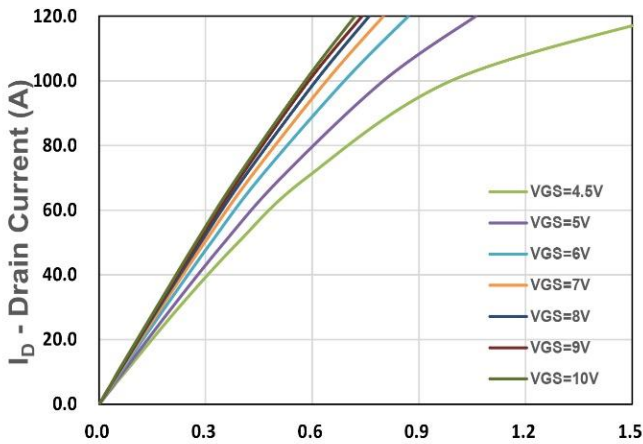

V_{DS} - Drain - Source Voltage (V)
Figure 1. Output Characteristics

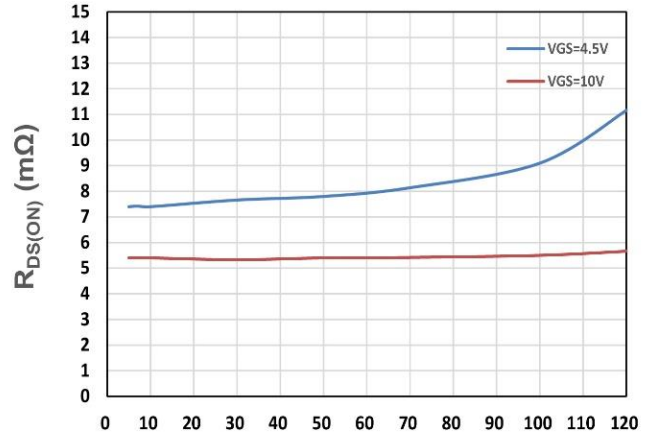

I_D - Drain Current (A)
Figure 2. On-Resistance vs. ID

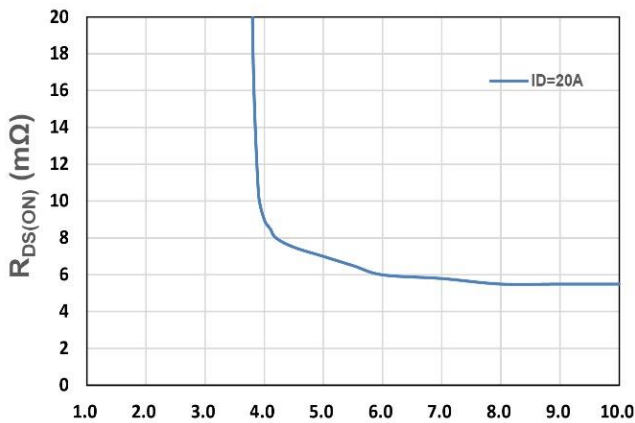

V_{GS} - Gate - Source Voltage (V)
Figure 3. On-Resistance vs. VGS

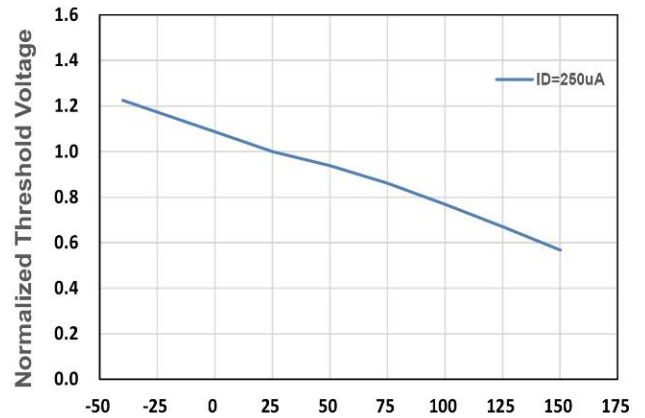

T_j, Junction Temperature(°C)
Figure 4. Gate Threshold Voltage

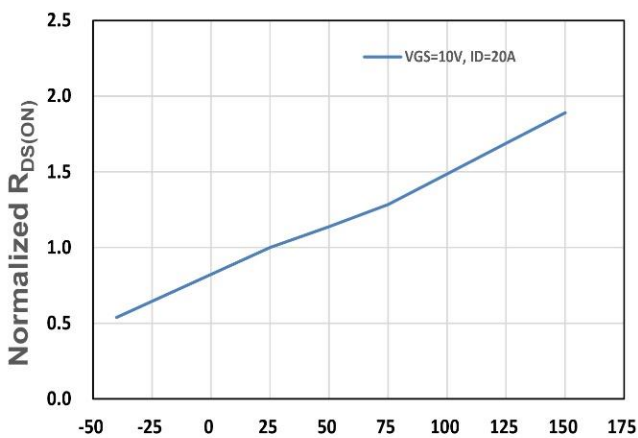

T_j, Junction Temperature(°C)
Figure 5. Drain-Source On Resistance

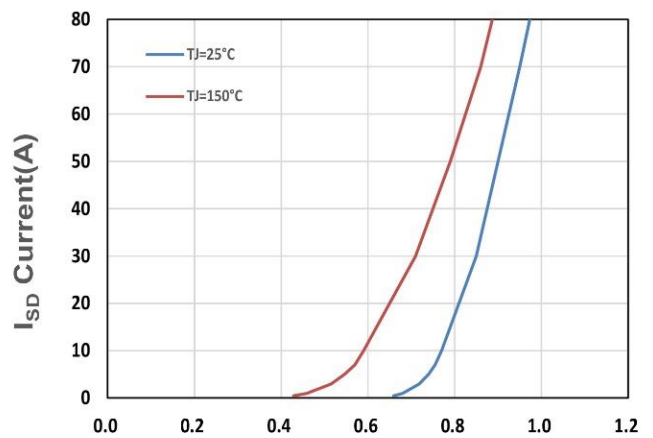

V_{SD}, Source-Drain Voltage(V)
Figure 6. Source-Drain Diode Forward

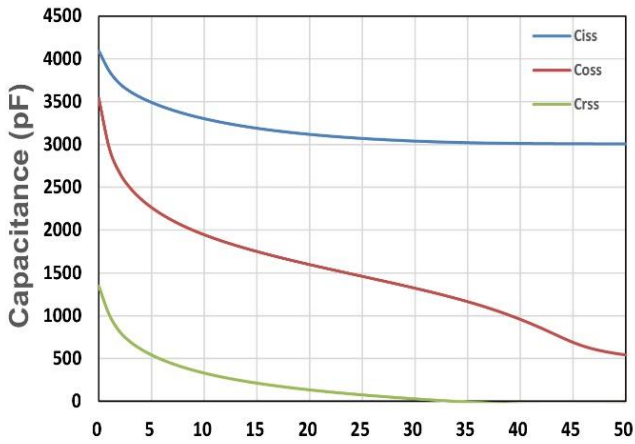

V_{DS} - Drain - Source Voltage (V)
Figure 7. Capacitance

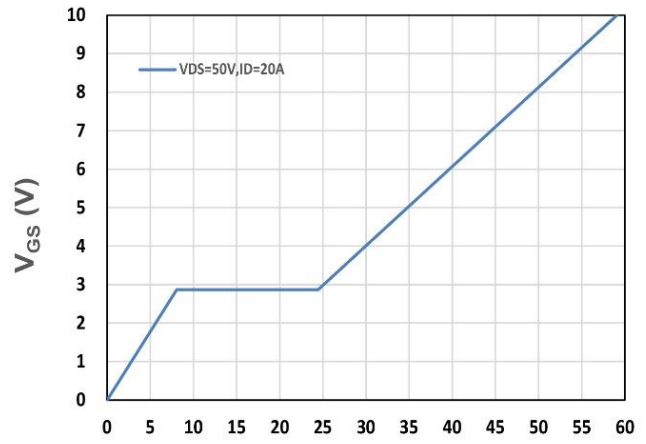

Q_g , Total Gate Charge (nC)
Figure 8. Gate Charge Characteristics

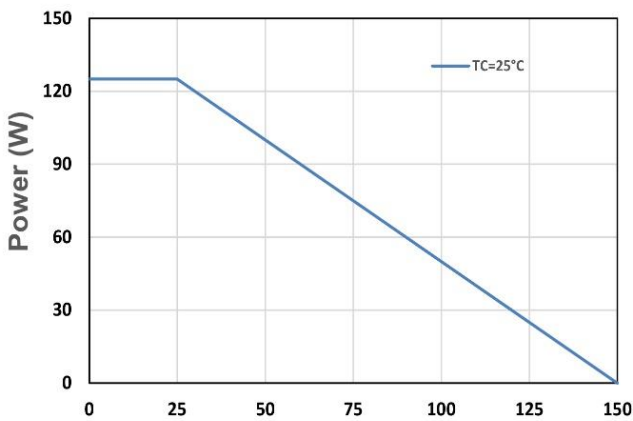

T_j - Junction Temperature ($^{\circ}C$)
Figure 9. Power Dissipation

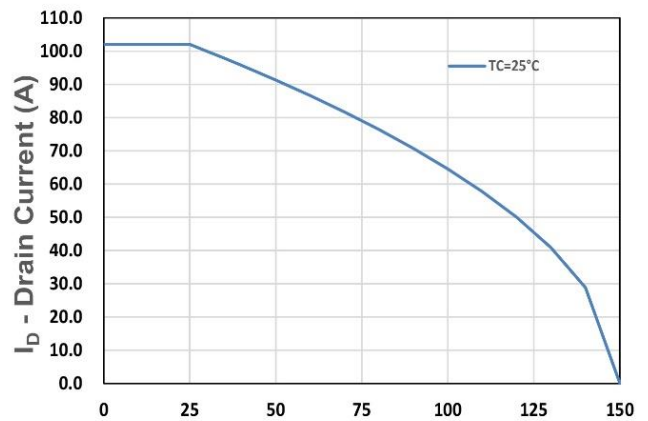

T_j - Junction Temperature ($^{\circ}C$)
Figure 10. Drain Current

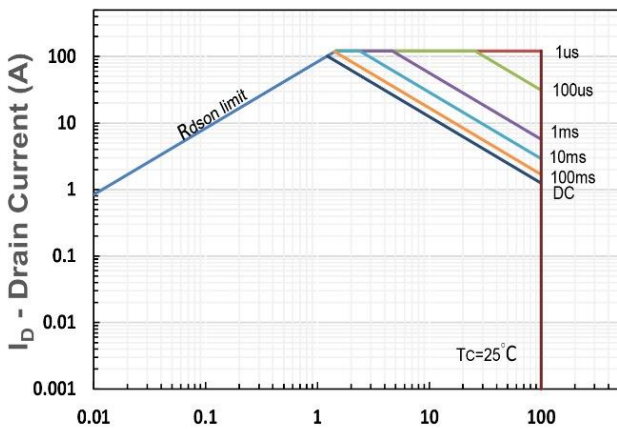

V_{DS} - Drain-Source Voltage (V)
Figure 11. Safe Operating Area

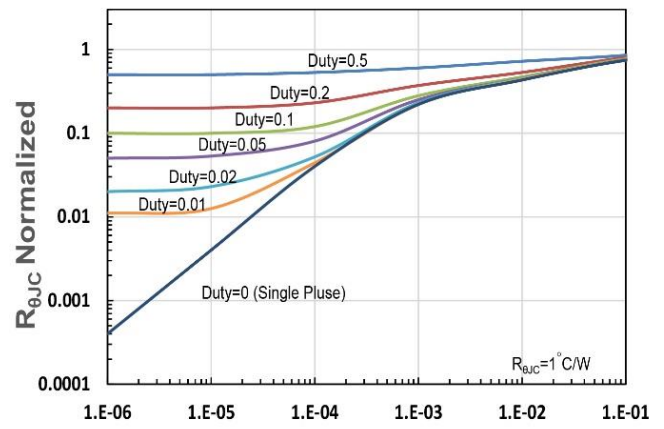

t_1 , Square Wave Pulse Duration (s)
Figure 12. $R_{\theta JC}$ Transient Thermal Impedance

TO-220 Package Outline Dimensions

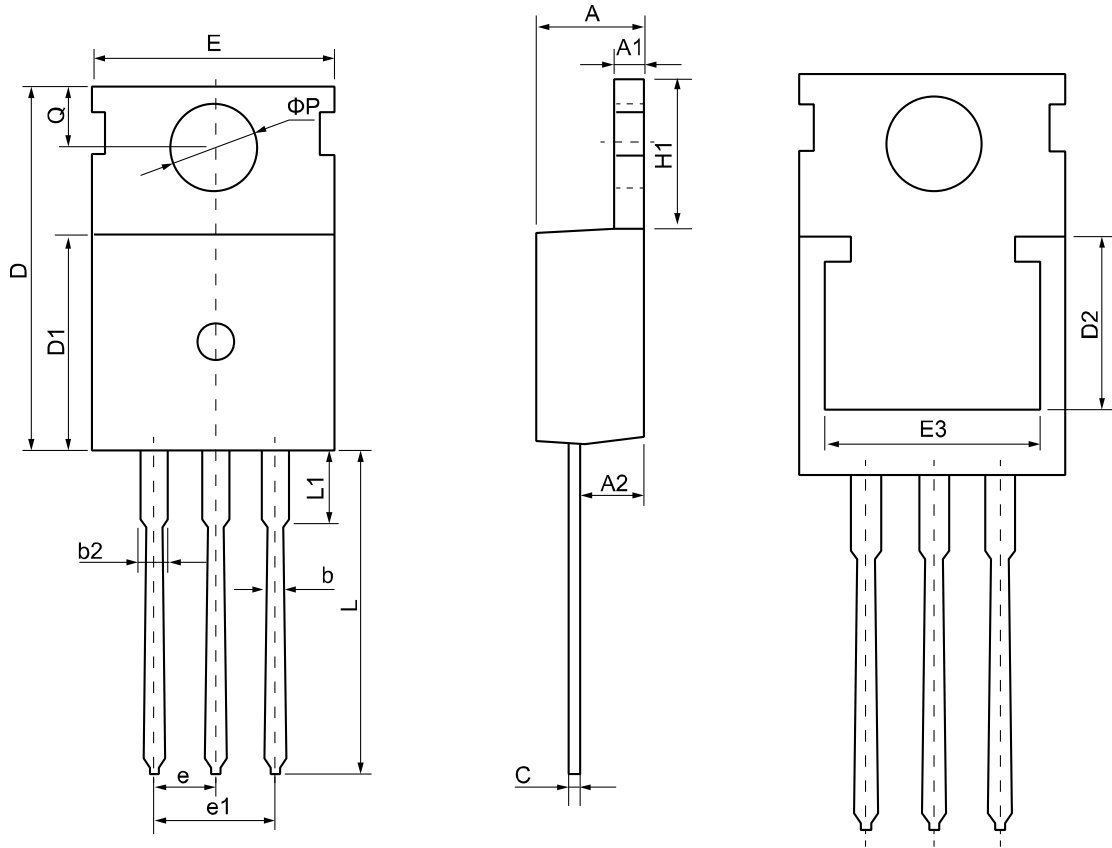

Symbol	Dimensions (unit:mm)			Symbol	Dimensions (unit:mm)		
	Min	Typ	Max		Min	Typ	Max
A	4.30	4.55	4.75	E	9.65	10.00	10.25
A1	1.15	1.30	1.45	E3	7.00	--	--
A2	2.20	2.40	2.60	e	2.54 BSC		
b	0.70	0.80	0.95	e1	5.08 BSC		
b2	1.17	1.27	1.47	H1	6.30	6.50	6.80
c	0.40	0.50	0.65	L	12.70	13.50	14.10
D	15.30	15.60	15.90	L1	--	3.20	3.95
D1	8.90	9.10	9.35	phi P	3.40	3.60	3.80
D2	5.50	--	--	Q	2.60	2.80	3.00