

**Features**

- Advanced Shield Gate Trench technology
- Super Low Gate Charge
- Excellent CdV/dt effect decline
- 100% EAS Guaranteed
- Green Device Available

**Product Summary**



$V_{DS}$	80	V
$I_D$	68	A
$R_{DS(ON)}$ (at $V_{GS}=10V$ )	12	m $\Omega$
$R_{DS(ON)}$ (at $V_{GS}=4.5V$ )	16	m $\Omega$

**Applications**

- High Frequency Point-of-Load, Synchronous Buck Converter
- Networking DC-DC Power System
- Load Switch

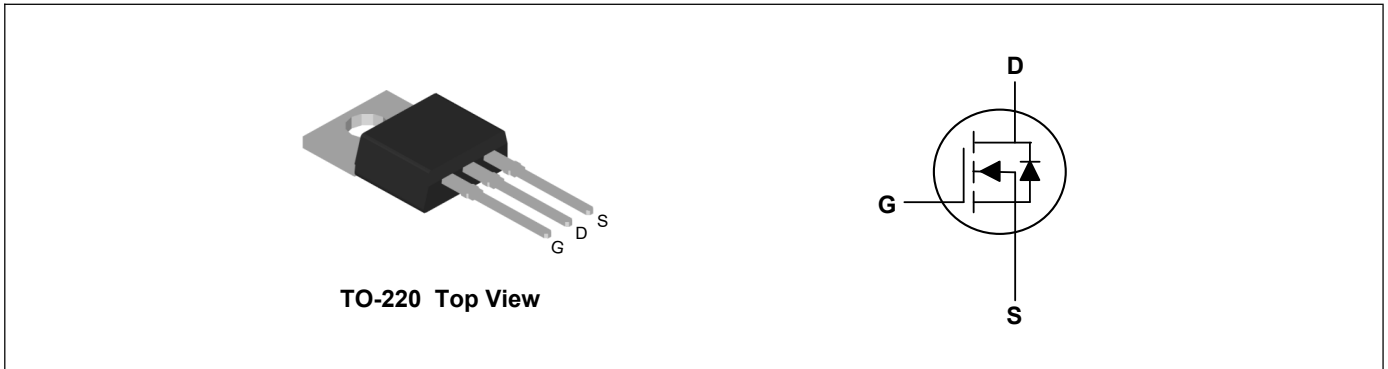

**Absolute Maximum Ratings( $T_C=25^{\circ}C$ , unless otherwise noted)**

Parameter	Symbol	Rating	Units
Drain-Source Voltage	$V_{DS}$	80	V
Gate-Source Voltage	$V_{GS}$	$\pm 20$	V
Continuous Drain Current <sup>1</sup>	$I_D$	68	A
Pulsed Drain Current <sup>2</sup>	$I_{DM}$	148	A
Single Pulse Avalanche Energy <sup>3</sup>	$E_{AS}$	180	mJ
Total Power Dissipation <sup>4</sup>	$P_D$	75	W
Storage Temperature Range	$T_{STG}$	-55 to 150	$^{\circ}C$
Operating Junction Temperature Range	$T_J$	-55 to 150	$^{\circ}C$

**Thermal Characteristics**

Parameter	Symbol	Typ	Max	Unit
Thermal Resistance Junction-Ambient <sup>1</sup>	$R_{\theta JA}$	---	62	$^{\circ}C/W$
Thermal Resistance Junction-Case <sup>1</sup>	$R_{\theta JC}$	---	2	$^{\circ}C/W$

**Electrical Characteristics (T<sub>J</sub>=25°C, unless otherwise noted)**

Parameter	Symbol	Conditions	Min	Typ	Max	Unit
Drain-Source Breakdown Voltage	BV <sub>DSS</sub>	V <sub>GS</sub> =0V, I <sub>D</sub> =250uA	80	---	---	V
Static Drain-Source On-Resistance	R <sub>DS(ON)</sub>	V <sub>GS</sub> =10V, I <sub>D</sub> =15A	---	9.5	12	mΩ
		V <sub>GS</sub> =4.5V, I <sub>D</sub> =12A	---	12	16	mΩ
Gate Threshold Voltage	V <sub>GS(th)</sub>	V <sub>GS</sub> =V <sub>DS</sub> , I <sub>D</sub> =250uA	1.0	1.8	2.5	V
Drain-Source Leakage Current	I <sub>DSS</sub>	V <sub>DS</sub> =480V, V <sub>GS</sub> =0V, T <sub>J</sub> =25°C	---	---	1	uA
Gate-Source Leakage Current	I <sub>GSS</sub>	V <sub>GS</sub> =±20V, V <sub>DS</sub> =0V	---	---	±100	nA
Total Gate Charge	Q <sub>g</sub>	V <sub>DD</sub> =40V, V <sub>GS</sub> =10V, I <sub>D</sub> =14.5A	---	26	---	nC
Gate-Source Charge	Q <sub>gs</sub>		---	6.4	---	
Gate-Drain Charge	Q <sub>gd</sub>		---	3.2	---	
Turn-On Delay Time	T <sub>d(on)</sub>	V <sub>DD</sub> =40V, V <sub>GS</sub> =10V, R <sub>G</sub> =3Ω, I <sub>D</sub> =14.5A	---	19	---	ns
Rise Time	T <sub>r</sub>		---	10	---	
Turn-Off Delay Time	T <sub>d(off)</sub>		---	24	---	
Fall Time	T <sub>f</sub>		---	5	---	
Input Capacitance	C <sub>iss</sub>	V <sub>DS</sub> =40V, V <sub>GS</sub> =0V, f=1MHz	---	1450	---	pF
Output Capacitance	C <sub>oss</sub>		---	200	---	
Reverse Transfer Capacitance	C <sub>rss</sub>		---	4	---	

**Drain-Source Diode Characteristics**

Parameter	Symbol	Conditions	Min	Typ	Max	Unit
Diode Forward Voltage <sup>2</sup>	V <sub>SD</sub>	V <sub>GS</sub> =0V, I <sub>S</sub> =15A, T <sub>J</sub> =25°C	---	0.8	1.2	V
Reverse Recovery Time	t <sub>rr</sub>	I <sub>F</sub> =10A, V <sub>R</sub> =40V di/dt=100A/μs, T <sub>J</sub> =25°C	---	17	---	nS
Reverse Recovery Charge	Q <sub>rr</sub>		---	63	---	nC

**Note:**

- 1.The data tested by surface mounted on a 1 inch<sup>2</sup> FR-4 board with 2OZ copper.
- 2.The data tested by pulsed , pulse width ≤ 300us , duty cycle ≤ 2%
- 3.The EAS data shows Max. rating . The test condition is V<sub>DD</sub>=50V, I<sub>D</sub>=30A
- 4.The power dissipation is limited by 150°C junction temperature

**Typical Characteristics**

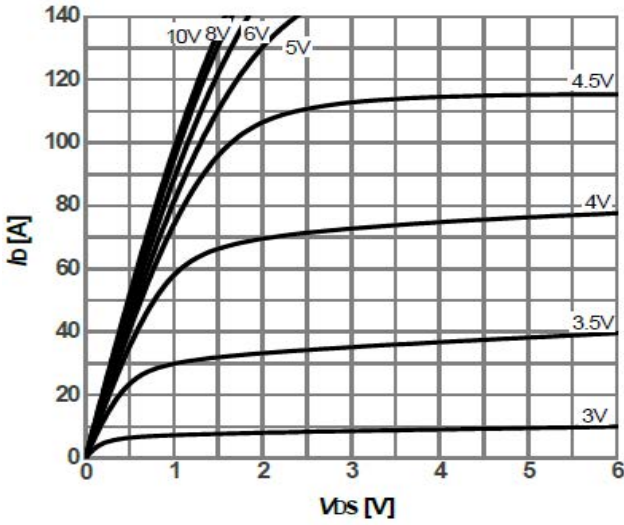

Typ. output characteristics

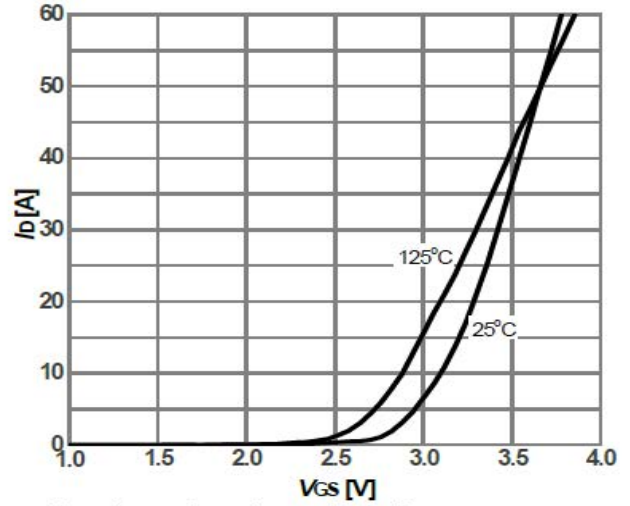

Typ. transfer characteristics

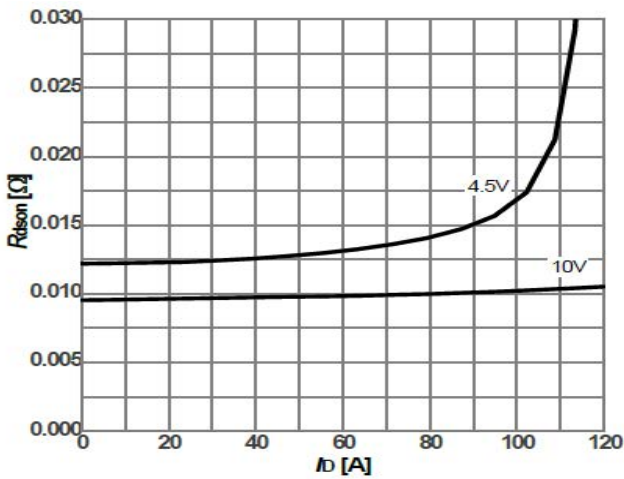

On-state resistance vs. Drain current

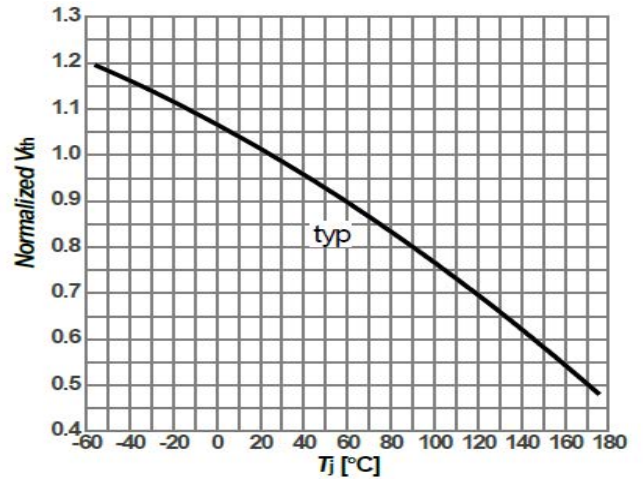

Gate threshold voltage vs. Junction temperature

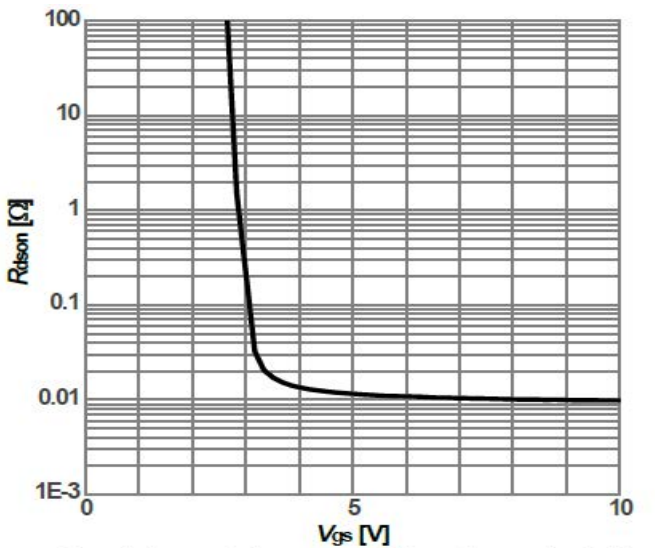

On-state resistance vs.  $V_{GS}$  characteristics

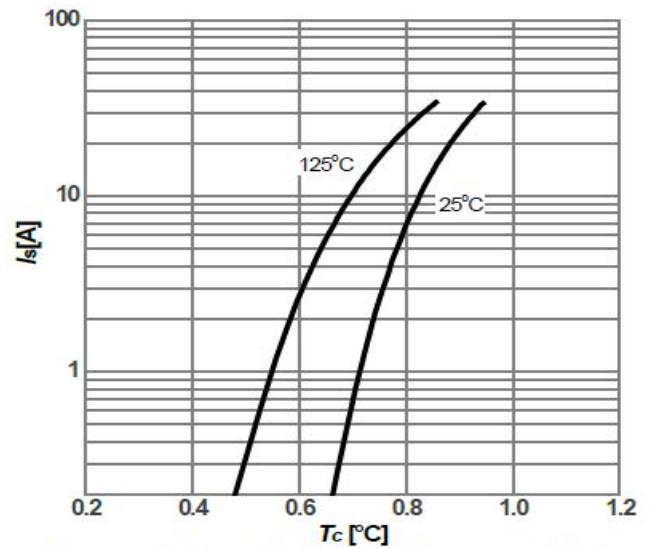

Forward characteristics of reverse diode

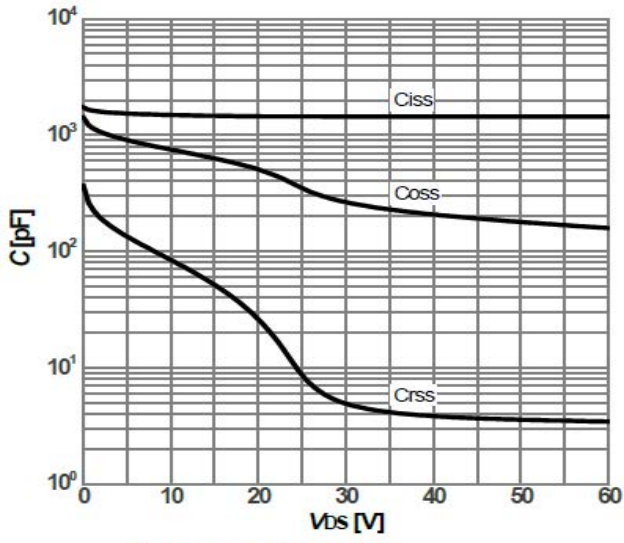

Typ. capacitances

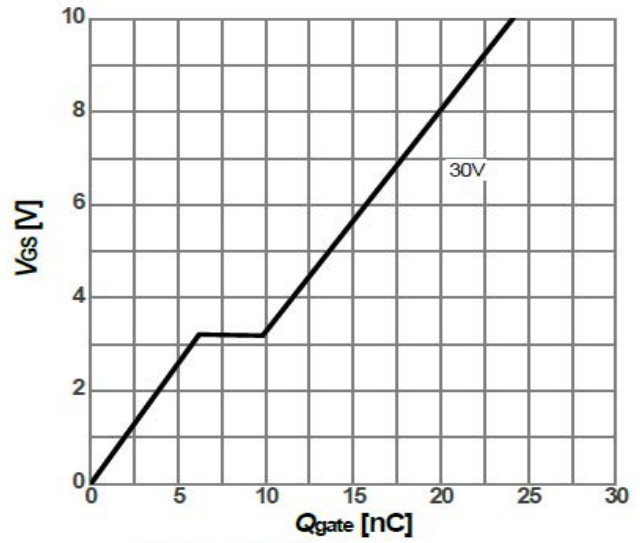

Typ. gate charge

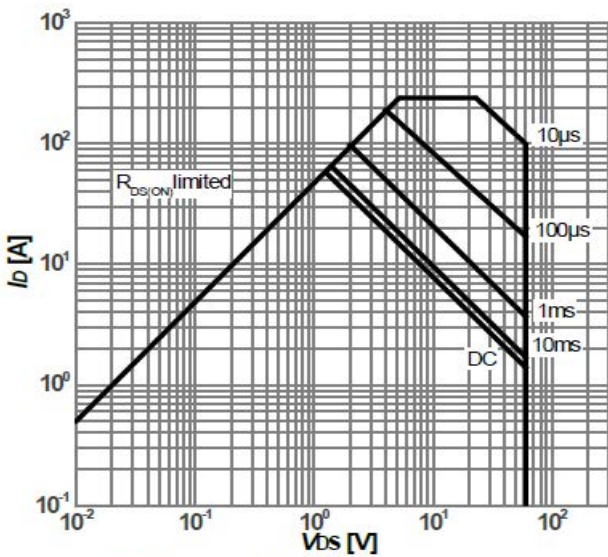

Safe operating area

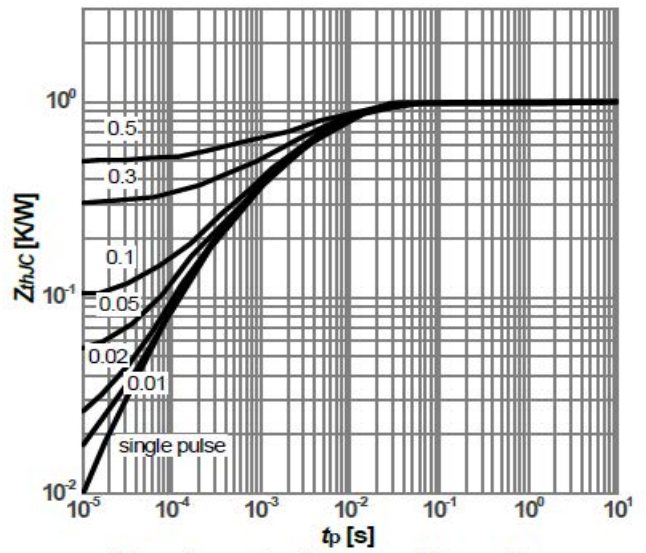

Max. transient thermal impedance

**TO-220 Package Outline Dimensions**

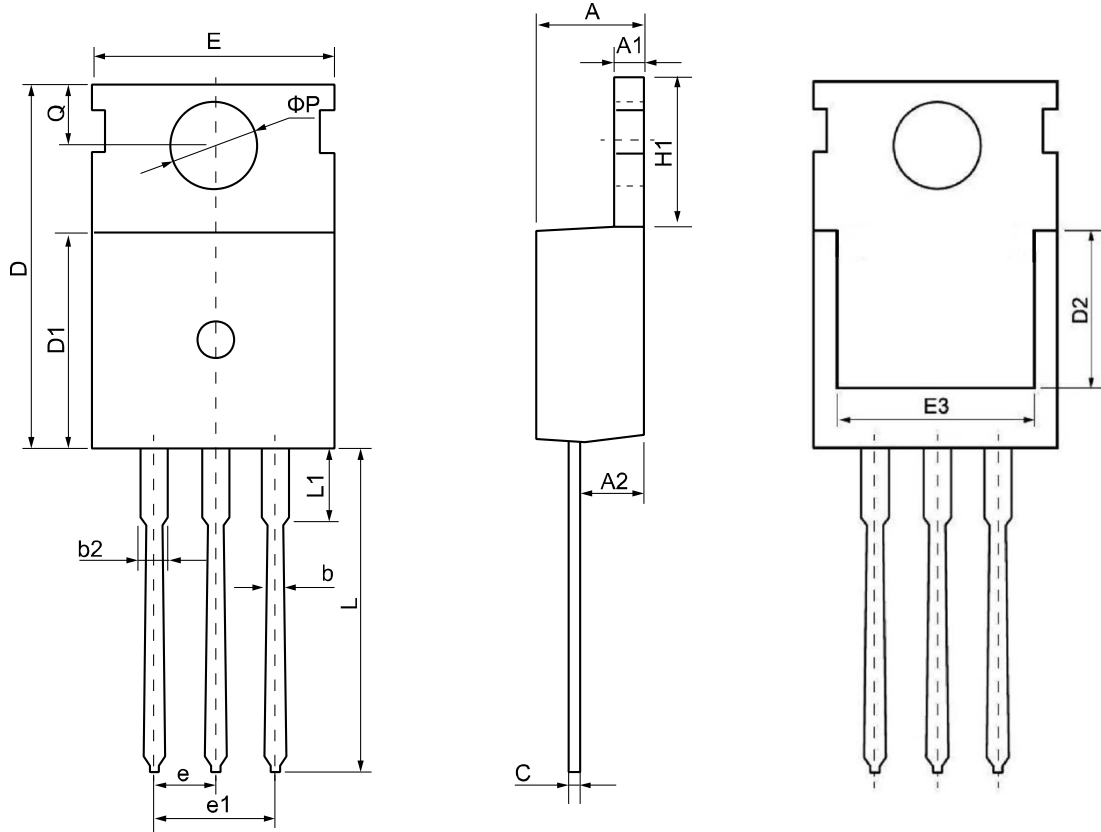

Symbol	Dimensions (unit:mm)			Symbol	Dimensions (unit:mm)		
	Min	Typ	Max		Min	Typ	Max
<b>A</b>	4.30	4.55	4.75	<b>E</b>	9.65	10.00	10.25
<b>A1</b>	1.15	1.30	1.45	<b>E3</b>	7.00	--	--
<b>A2</b>	2.20	2.40	2.60	<b>e</b>	2.54 BSC		
<b>b</b>	0.70	0.80	0.95	<b>e1</b>	5.08 BSC		
<b>b2</b>	1.17	1.27	1.47	<b>H1</b>	6.30	6.50	6.80
<b>c</b>	0.40	0.50	0.65	<b>L</b>	12.70	13.50	14.10
<b>D</b>	15.30	15.60	15.90	<b>L1</b>	--	3.20	3.95
<b>D1</b>	8.90	9.10	9.35	<b><math>\phi P</math></b>	3.40	3.60	3.80
<b>D2</b>	5.50	--	--	<b>Q</b>	2.60	2.80	3.00