

Features

- Advanced Shield Gate Trench technology
- Super Low Gate Charge
- High-Speed Switching
- 100% EAS Guaranteed
- Green Device Available

Product Summary



V_{DS}	40	V
I_D	250	A
$R_{DS(ON)}$ (at $V_{GS}=10V$)	2	m Ω
$R_{DS(ON)}$ (at $V_{GS}=4.5V$)	2.5	m Ω

Applications

- High Frequency Point-of-Load, Synchronous Buck Converter
- Networking DC-DC Power System
- Load Switch

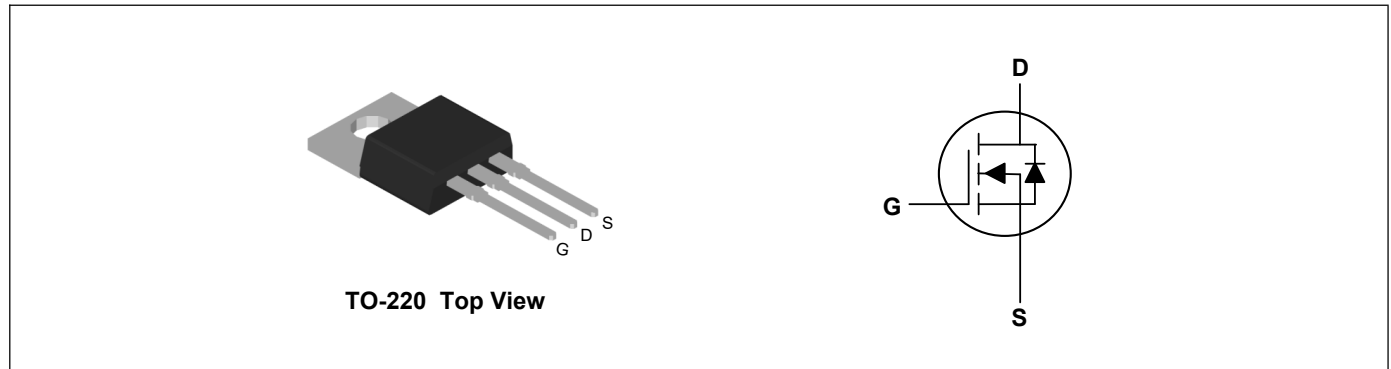

Absolute Maximum Ratings($T_C=25^\circ C$, unless otherwise noted)

Parameter	Symbol	Rating	Units
Drain-Source Voltage	V_{DS}	40	V
Gate-Source Voltage	V_{GS}	± 20	V
Continuous Drain Current ¹	I_D	250	A
Continuous Drain Current ¹	I_D	176	A
Pulsed Drain Current ²	I_{DM}	1000	A
Single Pulse Avalanche Energy ³	E_{AS}	196	mJ
Total Power Dissipation ⁴	P_D	180	W
Storage Temperature Range	T_{STG}	-55 to 175	$^\circ C$
Operating Junction Temperature Range	T_J	-55 to 175	$^\circ C$

Thermal Characteristics

Parameter	Symbol	Typ	Max	Unit
Thermal Resistance Junction-Ambient ¹	$R_{\theta JA}$	---	62.5	$^\circ C/W$
Thermal Resistance Junction-Case ¹	$R_{\theta JC}$	---	0.83	$^\circ C/W$

Electrical Characteristics (T_J=25°C, unless otherwise noted)

Parameter	Symbol	Conditions	Min	Typ	Max	Unit
Drain-Source Breakdown Voltage	BV _{DSS}	V _{GS} =0V, I _D =250uA	40	---	---	V
Static Drain-Source On-Resistance	R _{DS(ON)}	V _{GS} =10V, I _D =20A	---	1.4	2	mΩ
		V _{GS} =4.5V, I _D =15A	---	1.8	2.5	mΩ
Gate Threshold Voltage	V _{GS(th)}	V _{GS} =V _{DS} , I _D =250uA	1.0	---	2.3	V
Drain-Source Leakage Current	I _{DSS}	V _{DS} =40V, V _{GS} =0V	---	---	1	uA
Gate-Source Leakage Current	I _{GSS}	V _{GS} =±20V, V _{DS} =0V	---	---	±100	nA
Gate Resistance	R _g	V _{DS} =0V, V _{GS} =0V, f=1MHz	---	1.2	---	Ω
Total Gate Charge	Q _g	V _{DD} =20V, V _{GS} =10V, I _D =20A	---	52	---	nC
Gate-Source Charge	Q _{gs}		---	15	---	
Gate-Drain Charge	Q _{gd}		---	17	---	
Turn-On Delay Time	T _{d(on)}	V _{DD} =20V, V _{GS} =10V, R _G =3Ω, I _D =20A	---	15	---	ns
Rise Time	T _r		---	26	---	
Turn-Off Delay Time	T _{d(off)}		---	49	---	
Fall Time	T _f		---	20	---	
Input Capacitance	C _{iss}	V _{DS} =20V, V _{GS} =0V, f=1MHz	---	6000	---	pF
Output Capacitance	C _{oss}		---	2200	---	
Reverse Transfer Capacitance	C _{rss}		---	65	---	

Drain-Source Diode Characteristics

Parameter	Symbol	Conditions	Min	Typ	Max	Unit
Diode Forward Voltage ²	V _{SD}	V _{GS} =0V, I _S =20A, T _J =25°C	---	---	1.2	V
Reverse Recovery Time	t _{rr}	I _F =20A	---	57	---	nS
Reverse Recovery Charge	Q _{rr}	di/dt=100A/μs, T _J =25°C	---	98	---	nC

Note:

- 1.The data tested by surface mounted on a 1 inch² FR-4 board with 20Z copper.
- 2.The data tested by pulsed , pulse width ≤ 300us , duty cycle ≤ 2%
- 3.The EAS data shows Max. rating . The test condition is V_{DD}=30V,R_G=25Ω,L=0.5mH
- 4.The power dissipation is limited by 150°C junction temperature

Typical Characteristics

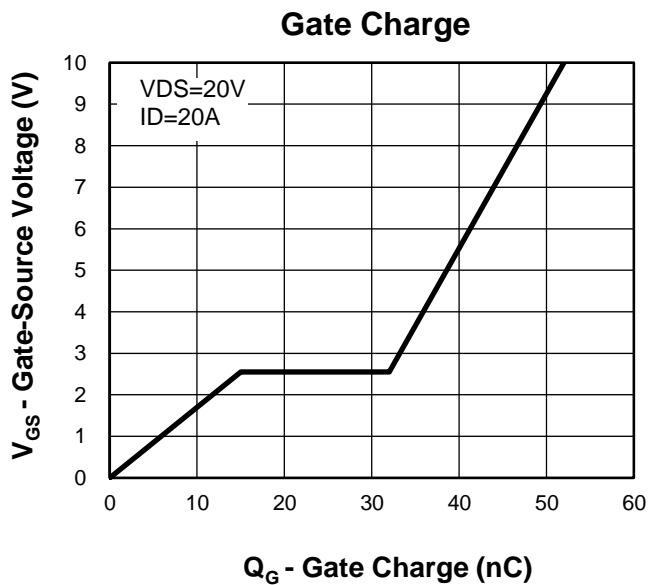
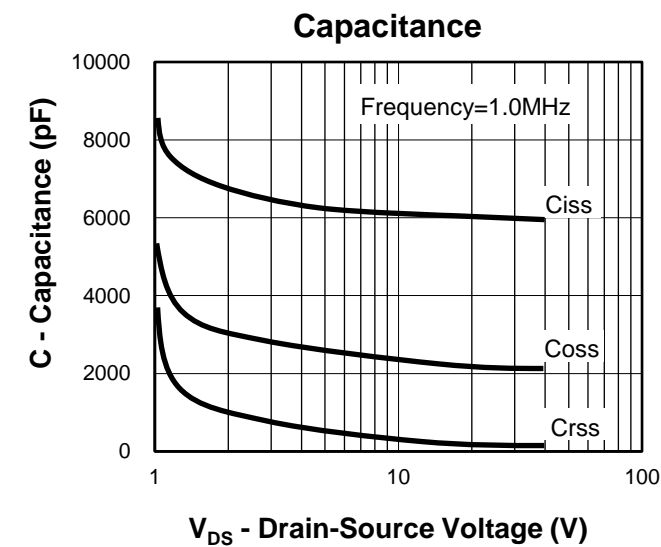
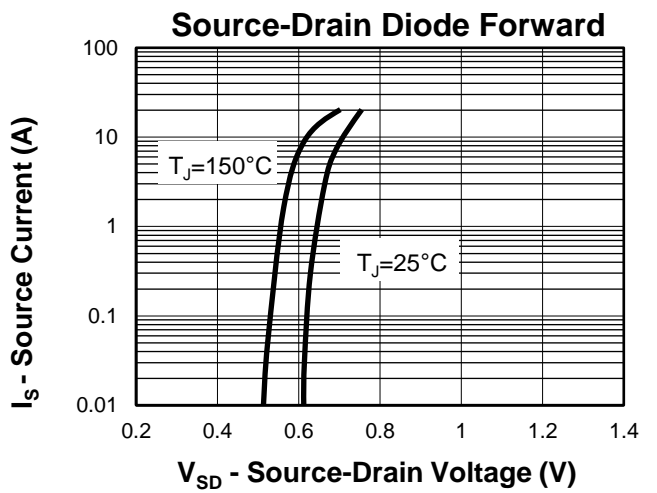
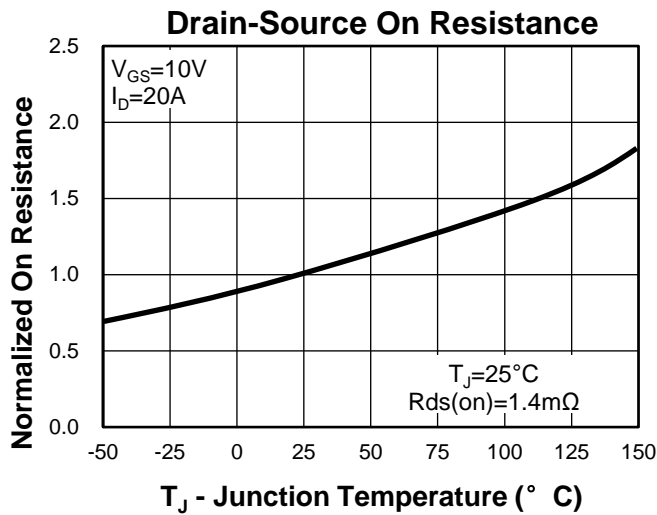
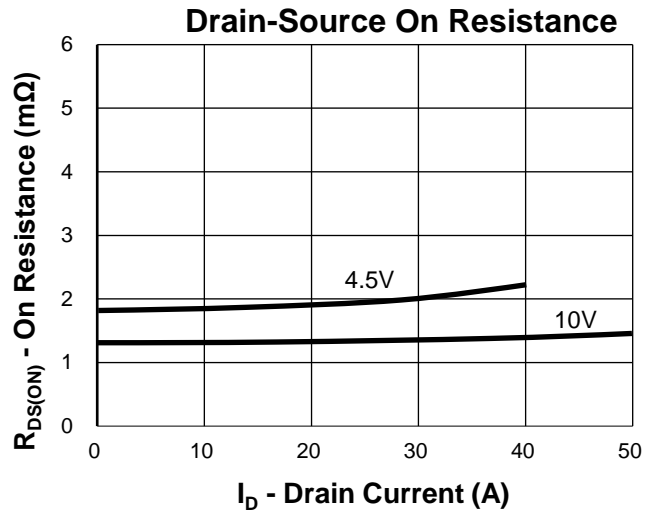
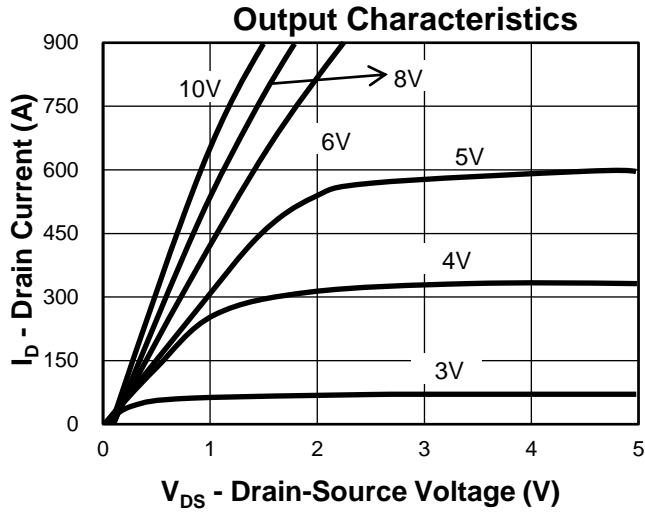

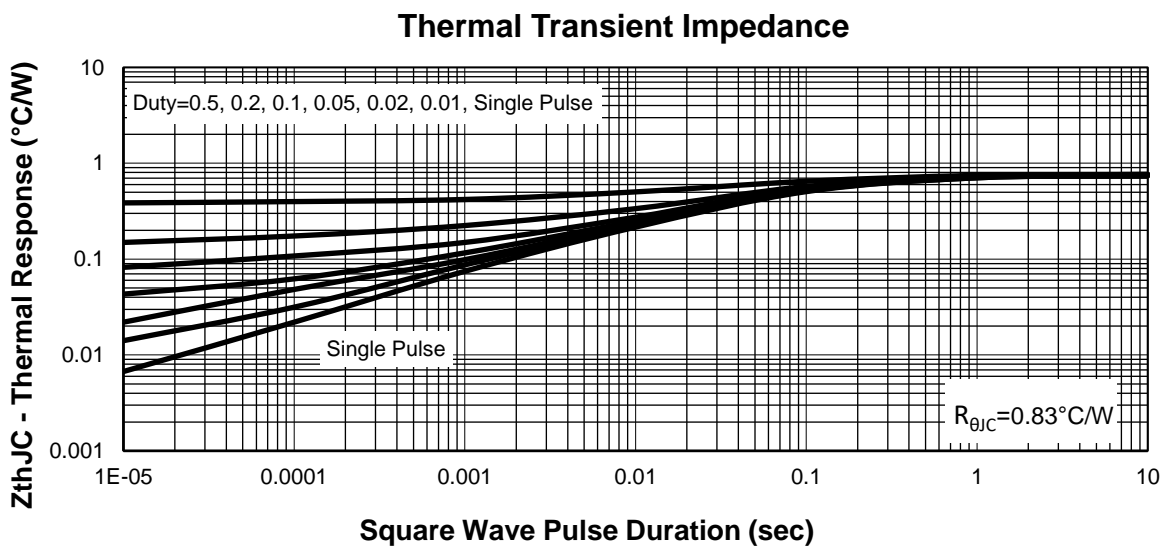
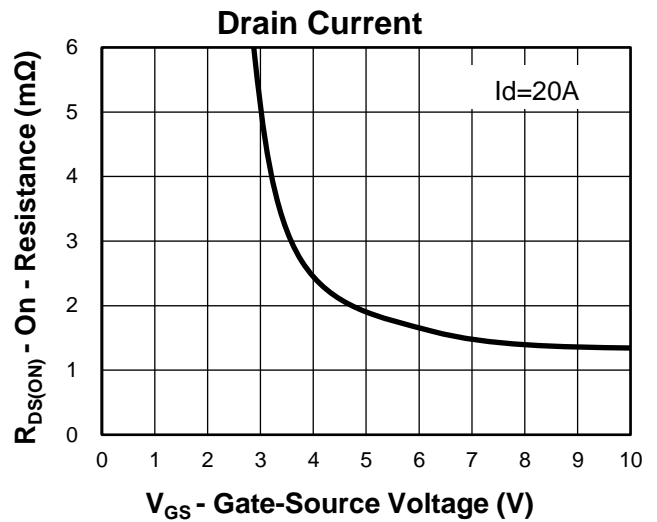
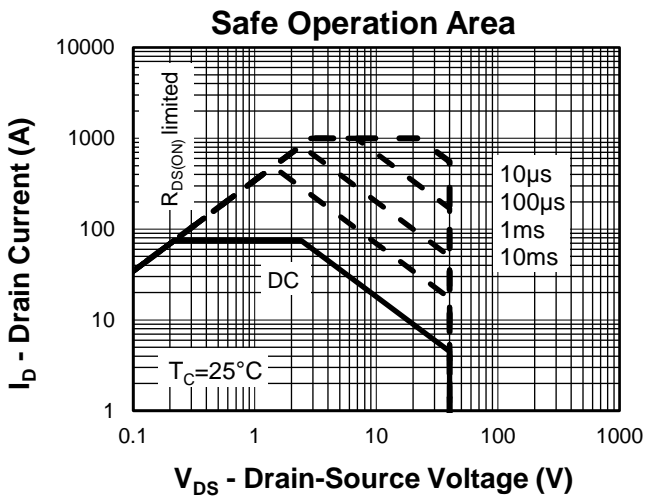
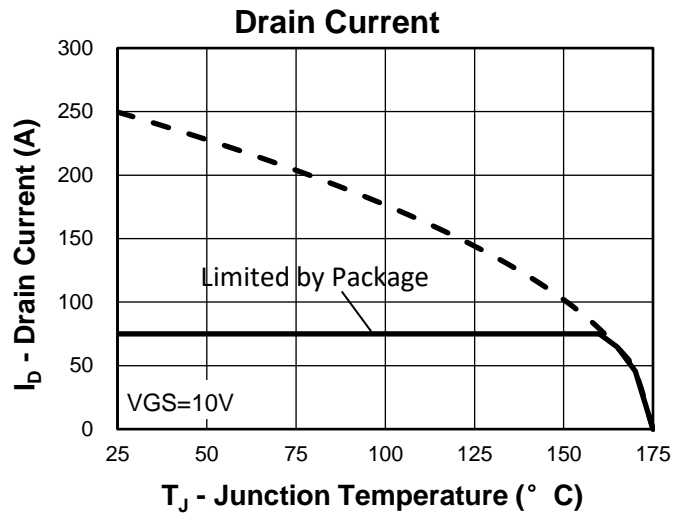
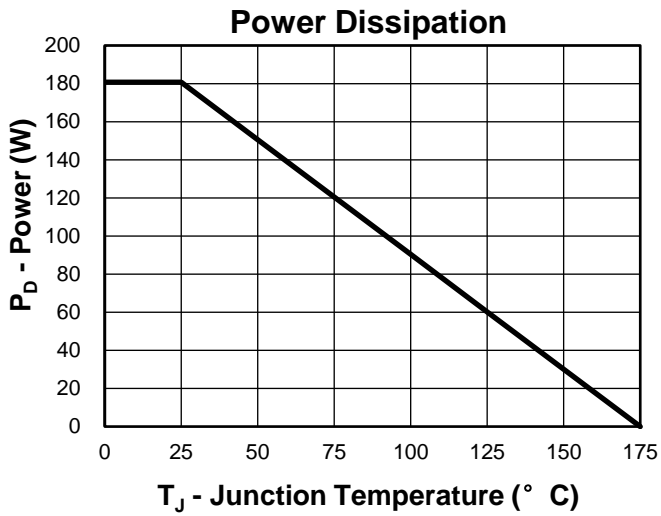

TO-220 Package Outline Dimensions

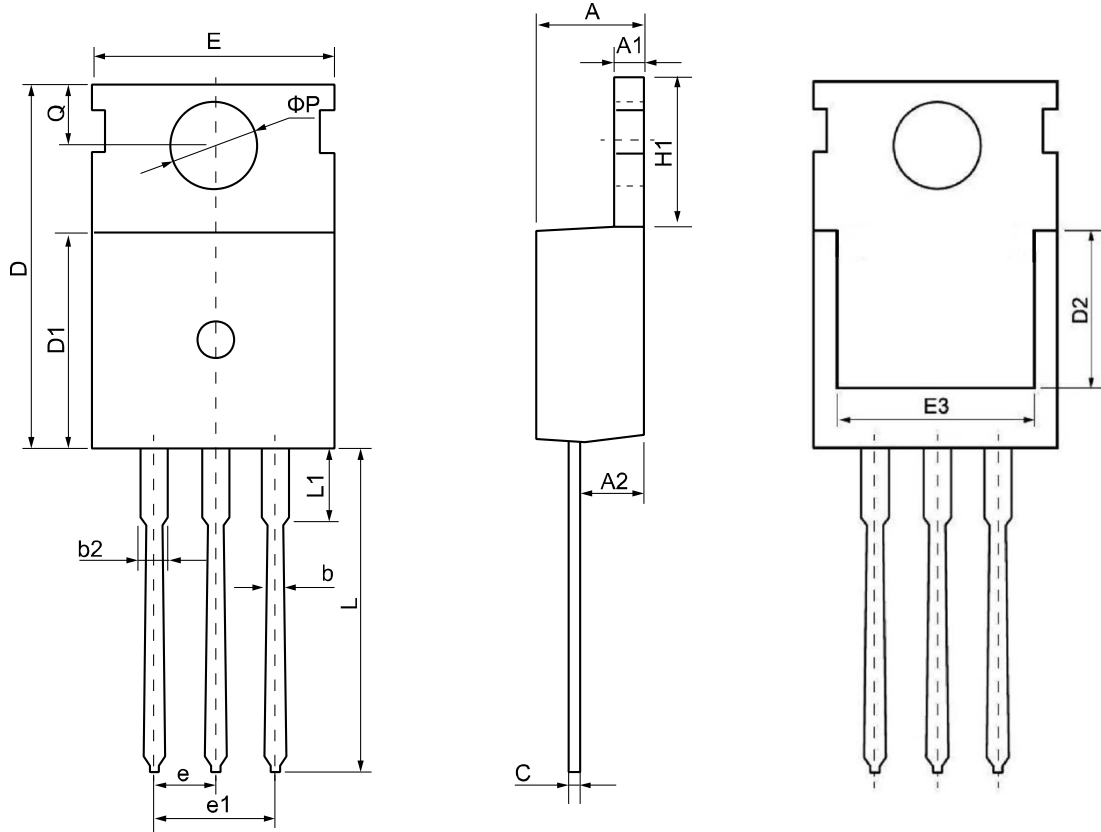

Symbol	Dimensions (unit:mm)			Symbol	Dimensions (unit:mm)		
	Min	Typ	Max		Min	Typ	Max
A	4.30	4.55	4.75	E	9.65	10.00	10.25
A1	1.15	1.30	1.45	E3	7.00	--	--
A2	2.20	2.40	2.60	e	2.54 BSC		
b	0.70	0.80	0.95	e1	5.08 BSC		
b2	1.17	1.27	1.47	H1	6.30	6.50	6.80
c	0.40	0.50	0.65	L	12.70	13.50	14.10
D	15.30	15.60	15.90	L1	--	3.20	3.95
D1	8.90	9.10	9.35	phi P	3.40	3.60	3.80
D2	5.50	--	--	Q	2.60	2.80	3.00