

**Features**

- Advanced high cell density Trench technology
- Super Low Gate Charge
- Excellent CdV/dt effect decline
- Green Device Available

**Product Summary**



$V_{DS}$	30	V
$I_D$	5.8	A
$R_{DS(ON)}$ (at $V_{GS}=10V$ )	27	m $\Omega$
$R_{DS(ON)}$ (at $V_{GS}=4.5V$ )	30	m $\Omega$

**Applications**

- High Frequency Point-of-Load, Synchronous Buck Converter
- Networking DC-DC Power System
- Load Switch

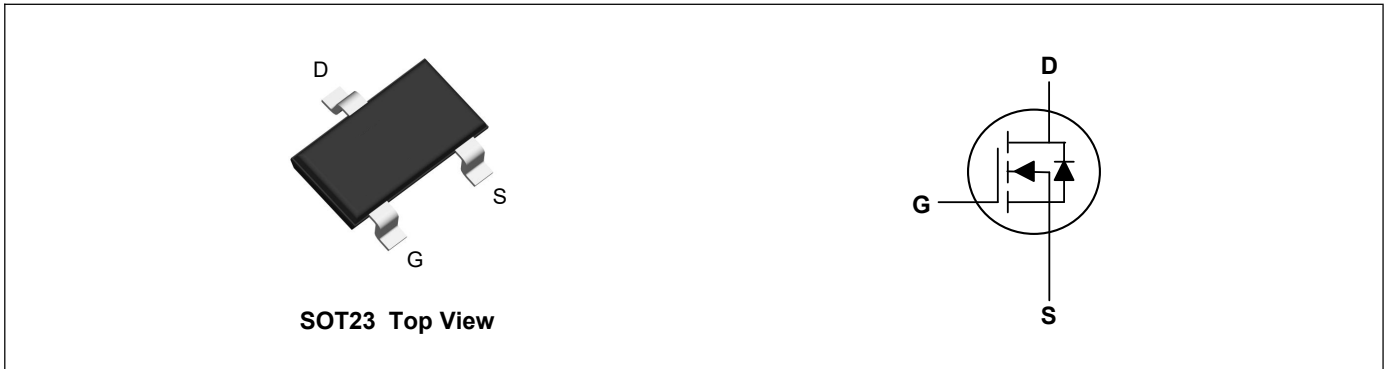

**Absolute Maximum Ratings( $T_A=25^{\circ}C$ , unless otherwise noted)**

Parameter	Symbol	Rating	Units
Drain-Source Voltage	$V_{DS}$	30	V
Gate-Source Voltage	$V_{GS}$	$\pm 12$	V
Continuous Drain Current	$I_D@T_A=25^{\circ}C$	5.8	A
Continuous Drain Current	$I_D@T_A=70^{\circ}C$	4.6	A
Pulsed Drain Current <sup>2</sup>	$I_{DM}$	23	A
Total Power Dissipation <sup>3</sup>	$P_D@T_A=25^{\circ}C$	1.5	W
Total Power Dissipation <sup>3</sup>	$P_D@T_A=70^{\circ}C$	0.9	W
Storage Temperature Range	$T_{STG}$	-55 to 150	$^{\circ}C$
Operating Junction Temperature Range	$T_J$	-55 to 150	$^{\circ}C$

**Thermal Characteristics**

Parameter	Symbol	Typ	Max	Unit
Thermal Resistance Junction-Ambient <sup>1</sup>	$R_{\theta JA}$	---	100	$^{\circ}C/W$

**Electrical Characteristics ( $T_J=25^{\circ}\text{C}$ , unless otherwise noted)**

Parameter	Symbol	Conditions	Min	Typ	Max	Unit
Drain-Source Breakdown Voltage	$BV_{DSS}$	$V_{GS}=0V, I_D=250\mu A$	30	---	---	V
Static Drain-Source On-Resistance <sup>2</sup>	$R_{DS(ON)}$	$V_{GS}=10V, I_D=5A$	---	22	27	m $\Omega$
		$V_{GS}=4.5V, I_D=4A$	---	25	30	m $\Omega$
		$V_{GS}=2.5V, I_D=2A$	---	32	40	m $\Omega$
Gate Threshold Voltage	$V_{GS(th)}$	$V_{GS}=V_{DS}, I_D=250\mu A$	0.5	---	1.5	V
Drain-Source Leakage Current	$I_{DSS}$	$V_{DS}=30V, V_{GS}=0V, T_A=25^{\circ}\text{C}$	---	---	1	$\mu A$
		$V_{DS}=24V, V_{GS}=0V, T_A=125^{\circ}\text{C}$	---	---	100	$\mu A$
Gate-Source Leakage Current	$I_{GSS}$	$V_{GS}=\pm 12V, V_{DS}=0V$	---	---	$\pm 100$	nA
Total Gate Charge	$Q_g$	$V_{DS}=15V, V_{GS}=4.5V, I_D=5A$	---	6.2	---	nC
Gate-Source Charge	$Q_{gs}$		---	1.2	---	
Gate-Drain Charge	$Q_{gd}$		---	1.9	---	
Turn-On Delay Time	$T_{d(on)}$	$V_{DD}=15V, V_{GS}=4V, R_G=3.3\Omega, I_D=5A$	---	7.5	---	ns
Rise Time	$T_r$		---	18	---	
Turn-Off Delay Time	$T_{d(off)}$		---	36	---	
Fall Time	$T_f$		---	5	---	
Input Capacitance	$C_{iss}$	$V_{DS}=15V, V_{GS}=0V, f=1\text{MHz}$	---	650	---	pF
Output Capacitance	$C_{oss}$		---	54	---	
Reverse Transfer Capacitance	$C_{rss}$		---	47	---	

**Drain-Source Diode Characteristics**

Parameter	Symbol	Conditions	Min	Typ	Max	Unit
Continuous Source Current <sup>1</sup>	$I_S$	$T_A=25^{\circ}\text{C}$	---	---	1.5	A
Diode Forward Voltage <sup>2</sup>	$V_{SD}$	$V_{GS}=0V, I_S=5A, T_J=25^{\circ}\text{C}$	---	0.83	1.2	V

**Note:**

- 1.The data tested by surface mounted on a 1 inch<sup>2</sup> FR-4 board with 2OZ copper.
- 2.The data tested by pulsed , pulse width  $\leq 300\mu s$  , duty cycle  $\leq 2\%$
- 3.The power dissipation is limited by 150 $^{\circ}\text{C}$  junction temperature

**Typical Characteristics**

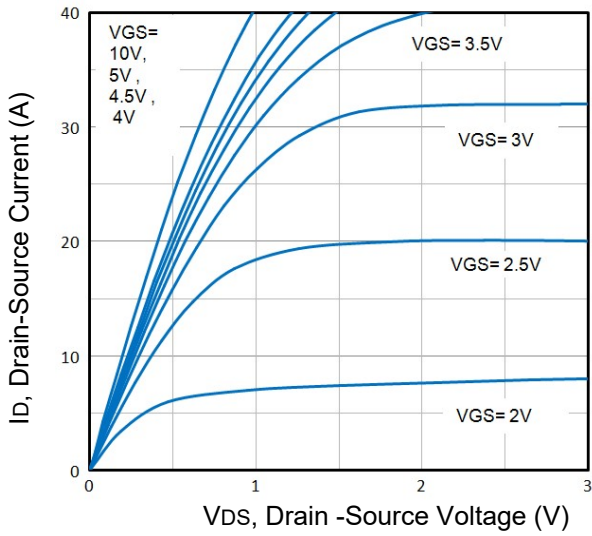

**Fig1.** Typical Output Characteristics

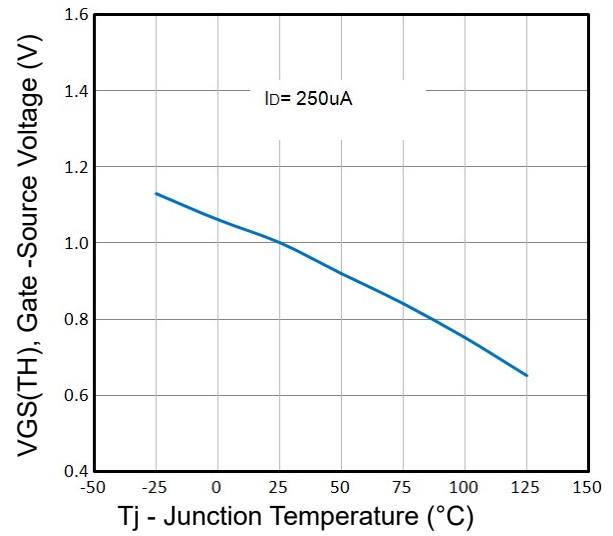

**Fig2.** Normalized Threshold Voltage Vs. Temperature

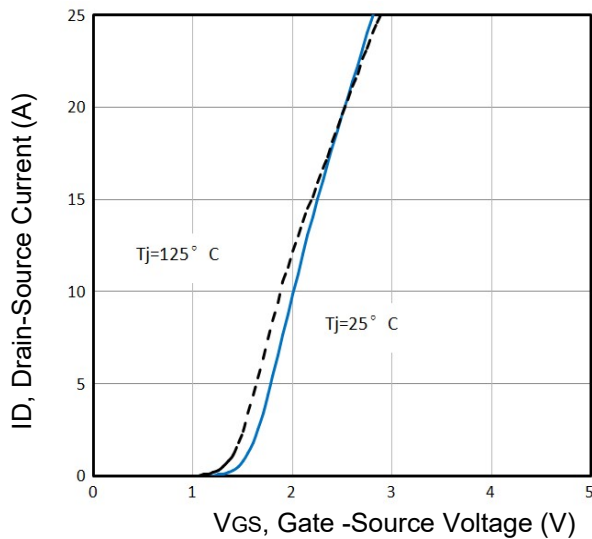

**Fig3.** Typical Transfer Characteristics

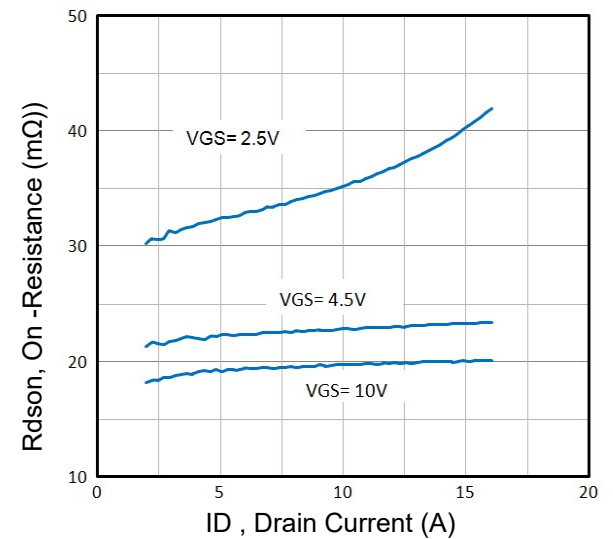

**Fig4.** On-Resistance vs. Drain Current and VGS

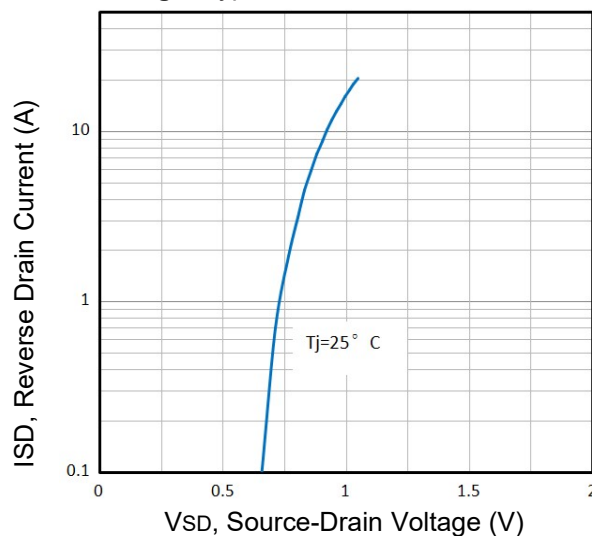

**Fig5.** Typical Source-Drain Diode Forward Voltage

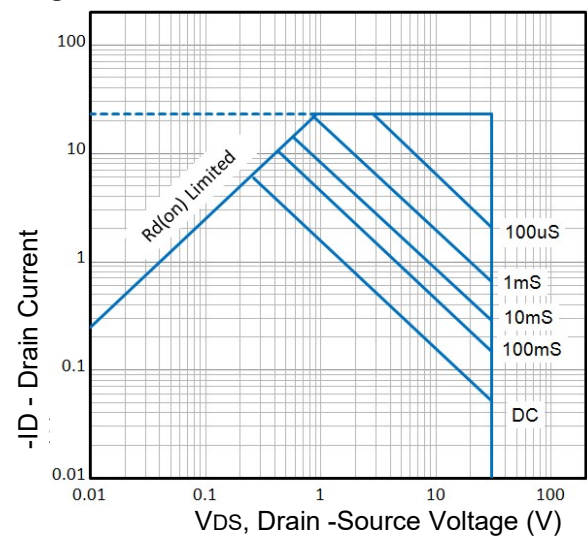

**Fig6.** Maximum Safe Operating Area

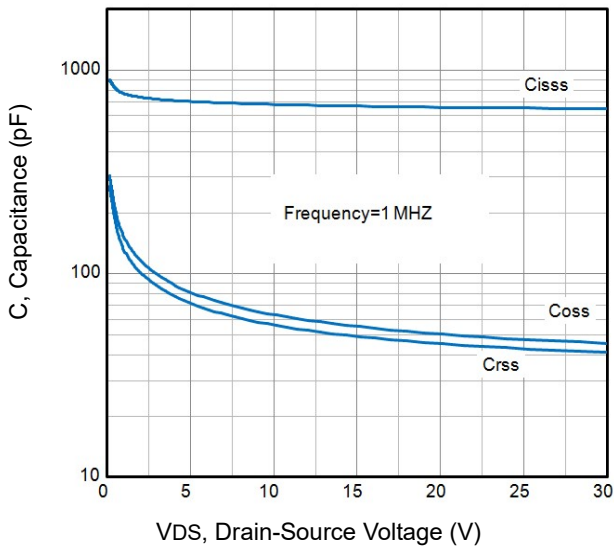

Fig7. Typical Capacitance Vs. Drain-Source Voltage

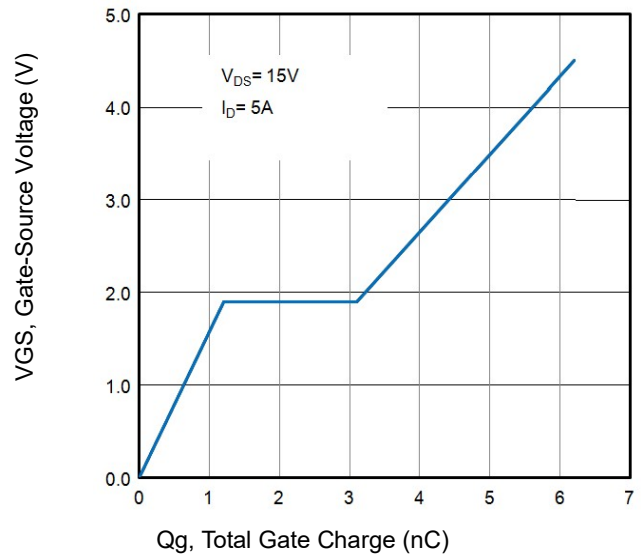

Fig8. Typical Gate Charge Vs. Gate-Source Voltage

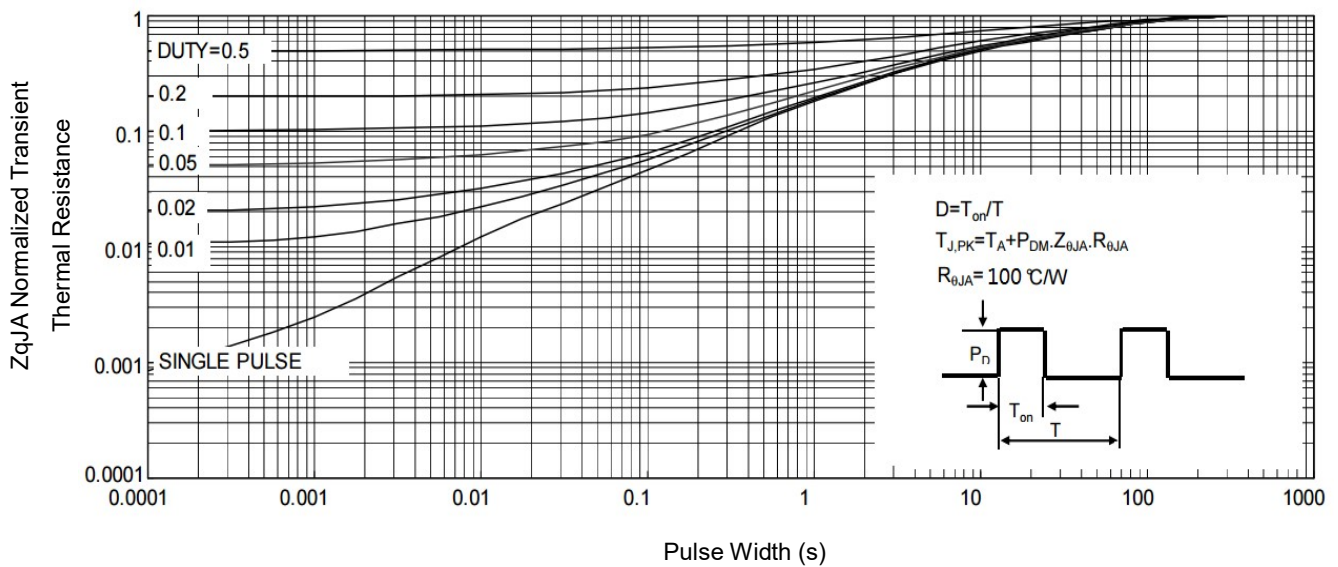

Fig9. Normalized Maximum Transient Thermal Impedance

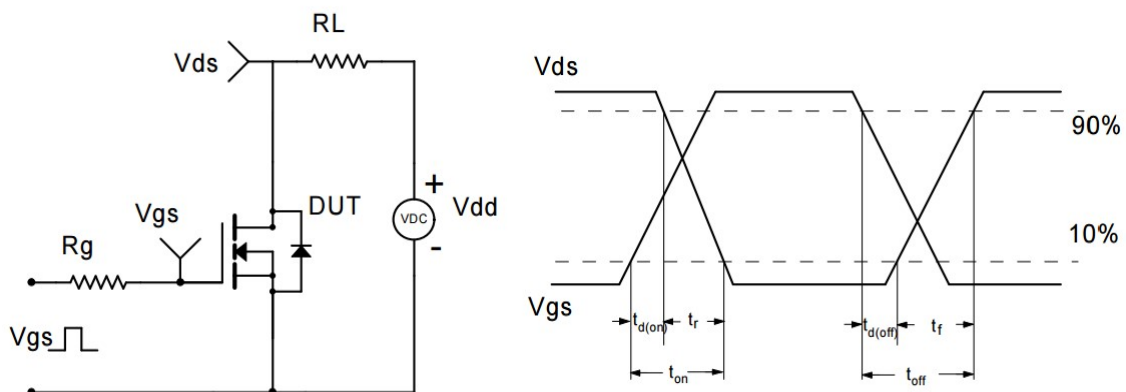
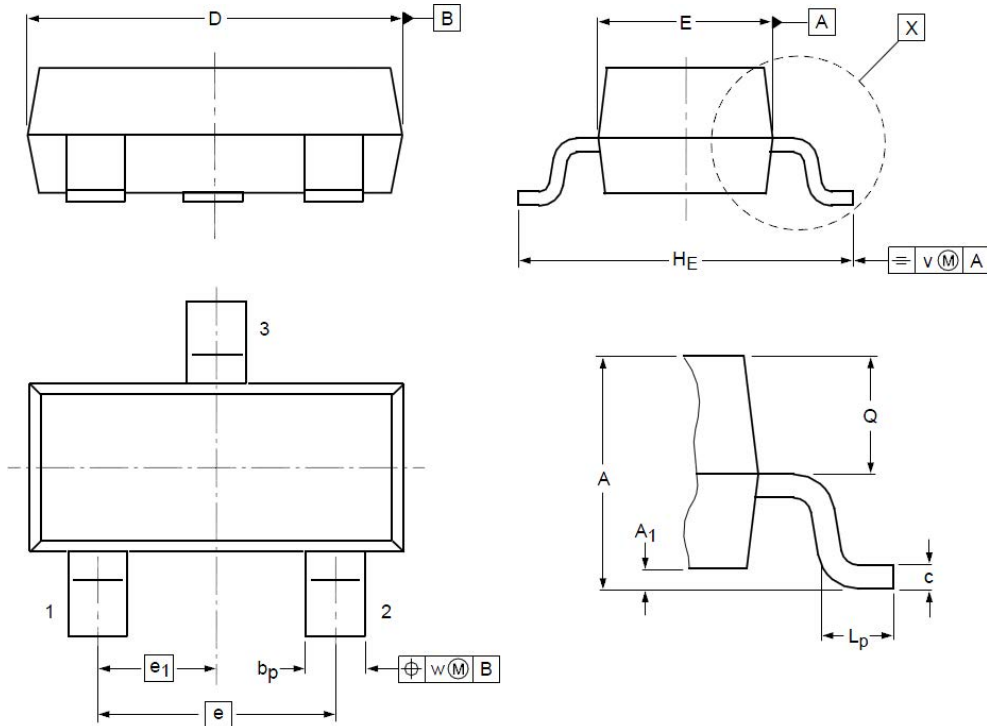

Fig10. Switching Time Test Circuit and waveforms

**SOT23 Package Outline Dimensions**



Symbol	Dimensions (unit:mm)			Symbol	Dimensions (unit:mm)		
	Min	Typ	Max		Min	Typ	Max
<b>A</b>	0.90	1.05	1.20	<b>e<sub>1</sub></b>	--	0.95	--
<b>A<sub>1</sub></b>	0.01	0.05	0.10	<b>H<sub>E</sub></b>	2.10	2.40	2.50
<b>b<sub>p</sub></b>	0.38	0.42	0.48	<b>L<sub>p</sub></b>	0.40	0.50	0.60
<b>c</b>	0.09	0.13	0.15	<b>Q</b>	0.45	0.49	0.55
<b>D</b>	2.80	2.92	3.00	<b>V</b>	--	0.20	--
<b>E</b>	1.20	1.33	1.40	<b>W</b>	--	0.10	--
<b>e</b>	--	1.90	--				