

Features

- Advanced high cell density Trench technology
- Super Low Gate Charge
- Excellent CdV/dt effect decline
- 100% EAS Guaranteed
- Green Device Available

Applications

- High Frequency Point-of-Load, Synchronous Buck Converter for MB/NB/UMPC/VGA
- Networking DC-DC Power System
- Load Switch

Product Summary



V_{DS}	-100	V
I_D	-30	A
$R_{DS(ON)}$ (at $V_{GS}=-10V$)	90	m Ω
$R_{DS(ON)}$ (at $V_{GS}=-4.5V$)	105	m Ω

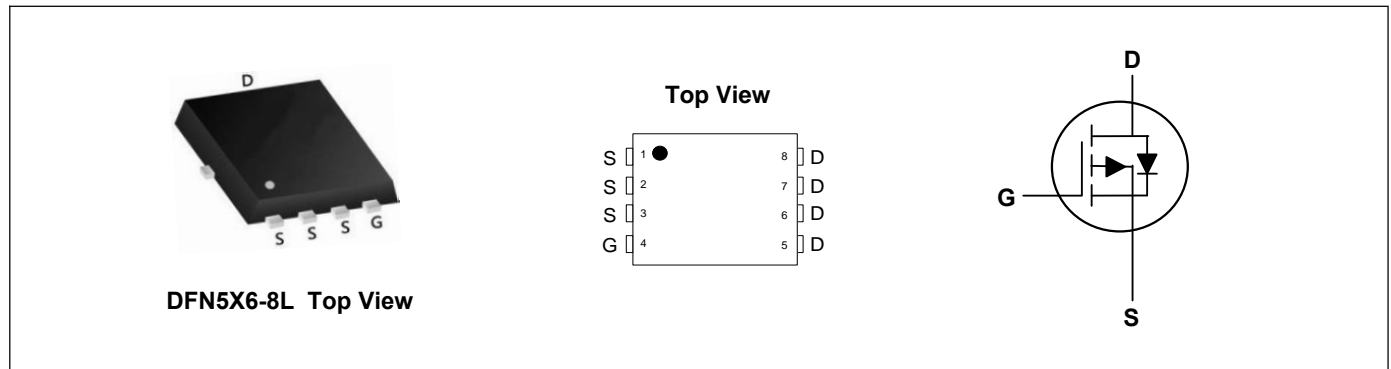

Absolute Maximum Ratings ($T_C=25^\circ C$, unless otherwise noted)

Parameter	Symbol	Rating	Units
Drain-Source Voltage	V_{DS}	-100	V
Gate-Source Voltage	V_{GS}	± 20	V
Continuous Drain Current, $V_{GS} @ -10V^1$	$I_D @ T_C=25^\circ C$	-30	A
Continuous Drain Current, $V_{GS} @ -10V^1$	$I_D @ T_C=100^\circ C$	-15	A
Pulsed Drain Current ²	I_{DM}	-75	A
Single Pulse Avalanche Energy ³	EAS	157.2	mJ
Avalanche Current	I_{AS}	18.9	A
Total Power Dissipation ⁴	$P_D @ T_C=25^\circ C$	50	W
Storage Temperature Range	T_{STG}	-55 to 150	$^\circ C$
Operating Junction Temperature Range	T_J	-55 to 150	$^\circ C$

Thermal Characteristics

Parameter	Symbol	Typ	Max	Unit
Thermal Resistance Junction-Ambient ¹	$R_{\theta JA}$	---	50	$^\circ C/W$
Thermal Resistance Junction-Case ¹	$R_{\theta JC}$	---	2.5	$^\circ C/W$

Electrical Characteristics (T_J=25°C, unless otherwise noted)

Parameter	Symbol	Conditions	Min	Typ	Max	Unit
Drain-Source Breakdown Voltage	BV _{DSS}	V _{GS} =0V, I _D =-250uA	-100	---	---	V
Static Drain-Source On-Resistance ²	R _{DS(ON)}	V _{GS} =-10V, I _D =-10A	---	70	90	mΩ
		V _{GS} =-4.5V, I _D =-8A	---	80	105	mΩ
Gate Threshold Voltage	V _{GS(th)}	V _{GS} =V _{DS} , I _D =-250uA	-1.2	-1.6	-2.5	V
Drain-Source Leakage Current	I _{DSS}	V _{DS} =-100V, V _{GS} =0V, T _J =25°C	---	---	-50	uA
Gate-Source Leakage Current	I _{GSS}	V _{GS} =±20V, V _{DS} =0V	---	---	±100	nA
Forward Transconductance	g _{fs}	V _{DS} =-10V, I _D =-10A	---	24	---	S
Total Gate Charge	Q _g	V _{DS} =-50V, V _{GS} =-10V, I _D =-20A	---	48.5	---	nC
Gate-Source Charge	Q _{gs}		---	9.13	---	
Gate-Drain Charge	Q _{gd}		---	5.93	---	
Turn-On Delay Time	T _{d(on)}	V _{DD} =-50V, V _{GS} =-10V, R _G =3.3Ω, I _D =-10A	---	12	---	ns
Rise Time	T _r		---	27.4	---	
Turn-Off Delay Time	T _{d(off)}		---	79	---	
Fall Time	T _f		---	53.6	---	
Input Capacitance	C _{iss}	V _{DS} =-20V, V _{GS} =0V, f=1MHz	---	3689	---	pF
Output Capacitance	C _{oss}		---	129	---	
Reverse Transfer Capacitance	C _{rss}		---	76	---	

Drain-Source Diode Characteristics

Parameter	Symbol	Conditions	Min	Typ	Max	Unit
Continuous Source Current ^{1,5}	I _S	V _G =V _D =0V, Force Current	---	---	-30	A
Diode Forward Voltage ²	V _{SD}	V _{GS} =0V, I _S =-1A, T _J =25°C	---	---	-1.2	V
Reverse Recovery Time	t _{rr}	I _F =-8A, di/dt=100A/μs, T _J =25°C	---	38.7	---	nS
Reverse Recovery Charge	Q _{rr}		---	22.4	---	nC

Note:

- The data tested by surface mounted on a 1 inch² FR-4 board with 2OZ copper.
- The data tested by pulsed, pulse width ≤ 300us, duty cycle ≤ 2%
- The EAS data shows Max. rating. The test condition is V_{DD}=-25V, V_{GS}=-10V, L=0.88mH, I_{AS}=-18.9A
- The power dissipation is limited by 150°C junction temperature
- The data is theoretically the same as I_D and I_{DM}, in real applications, should be limited by total power dissipation.

Typical Characteristics

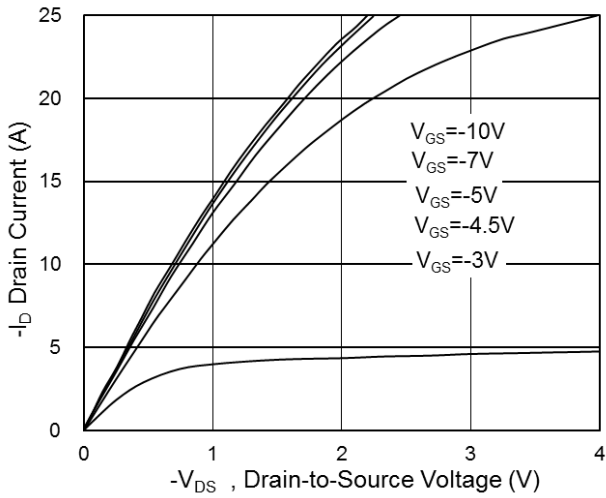

Fig.1 Typical Output Characteristics

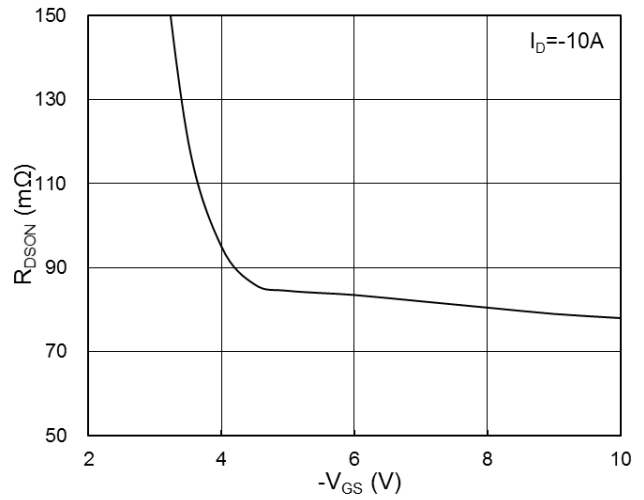

Fig.2 On-Resistance vs G-S Voltage

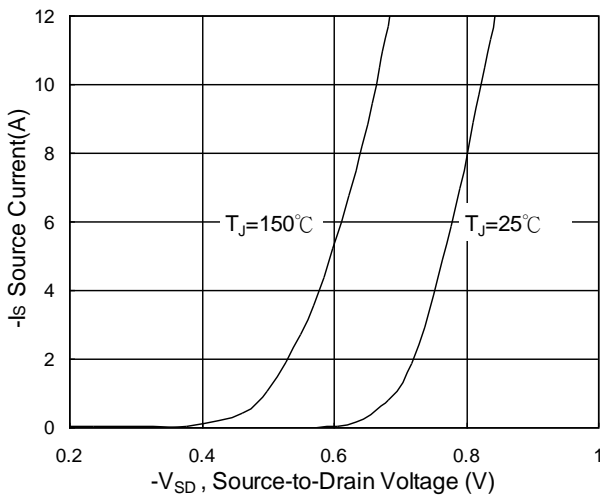

Fig.3 Typical S-D Diode Forward Voltage

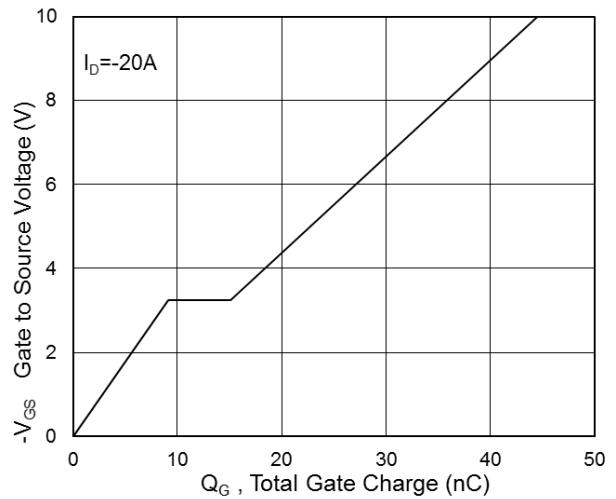

Fig.4 Gate-Charge Characteristics

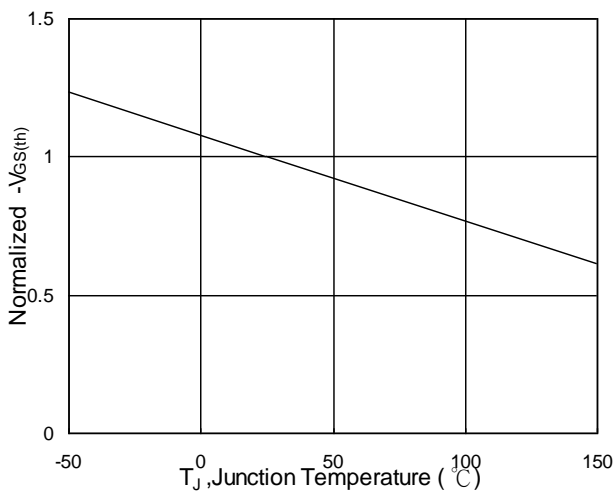

Fig.5 Normalized $V_{GS(th)}$ vs T_J

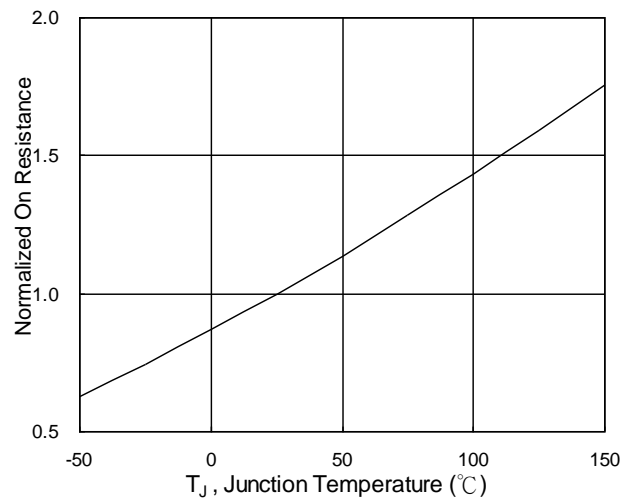

Fig.6 Normalized $R_{DS(on)}$ vs T_J

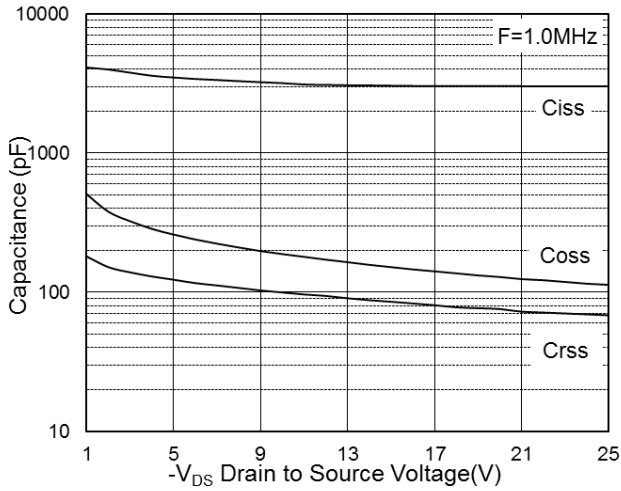

Fig.7 Capacitance

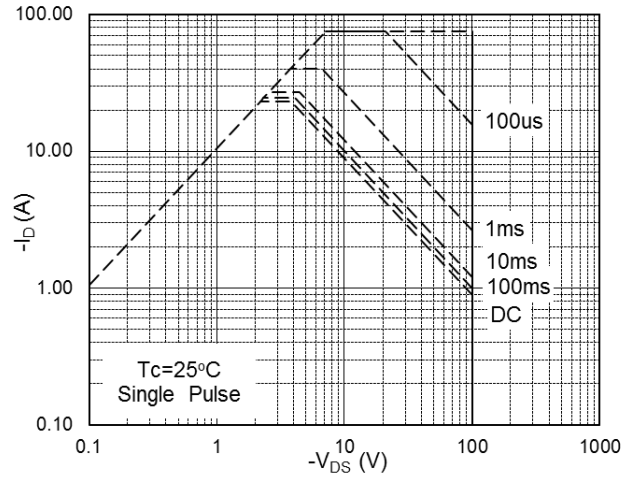

Fig.8 Safe Operating Area

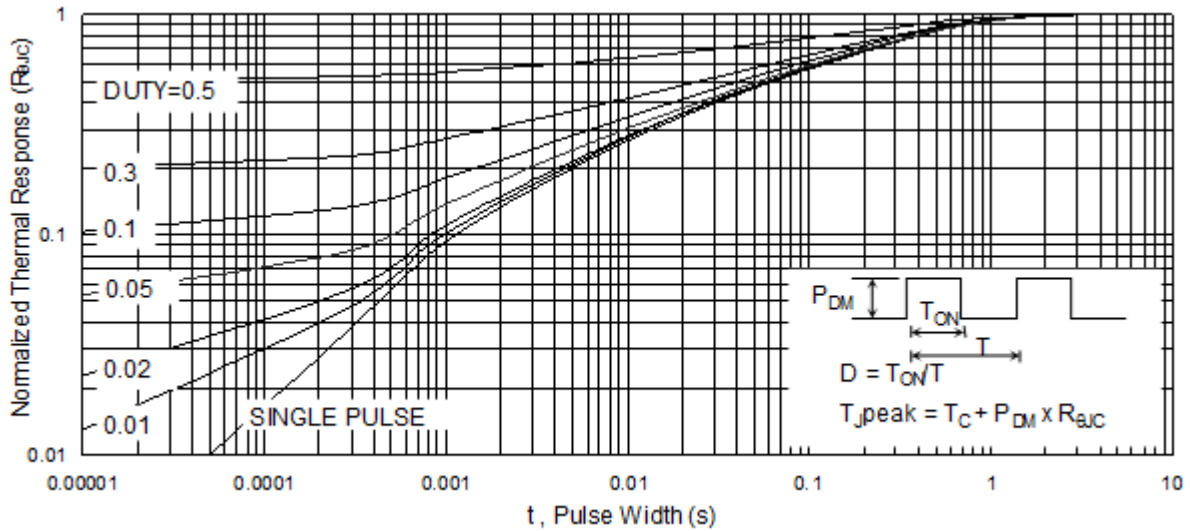

Fig.9 Normalized Maximum Transient Thermal Impedance

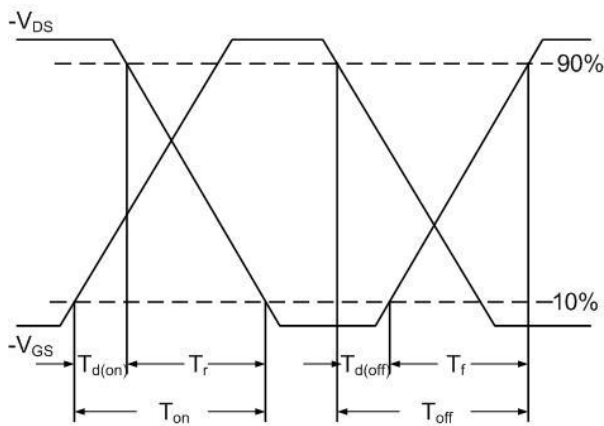

Fig.10 Switching Time Waveform

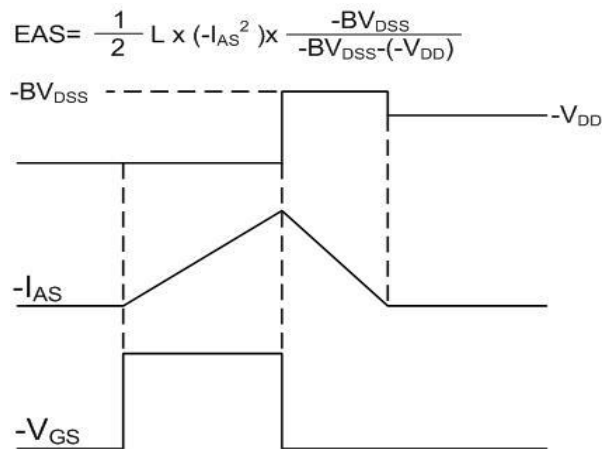
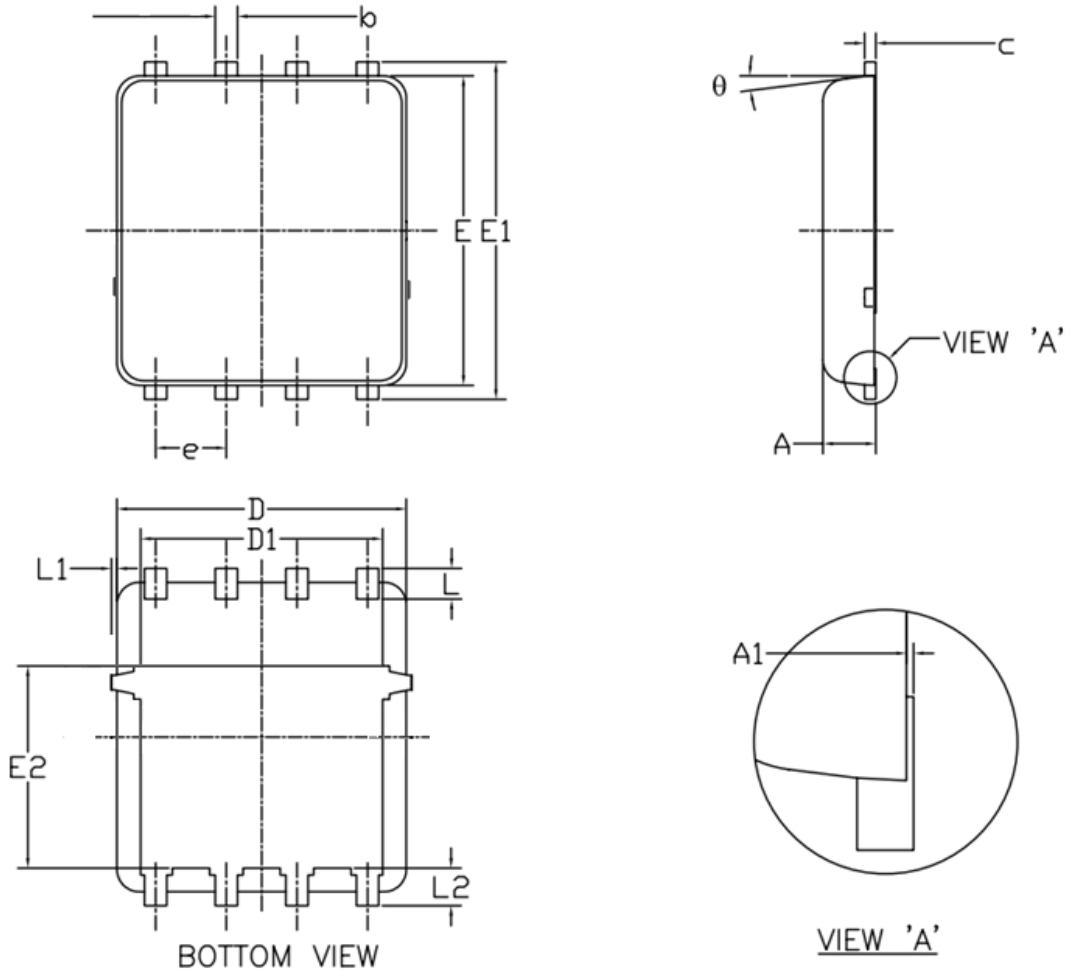

Fig.11 Unclamped Inductive Waveform

DFN5X6-8L Package Outline Dimensions



Symbol	Dimensions (unit:mm)			Symbol	Dimensions (unit:mm)		
	Min	Typ	Max		Min	Typ	Max
A	0.90	1.00	1.20	E1	5.90	6.10	6.35
A1	0.00	--	0.05	E2	3.38	3.58	3.92
b	0.30	0.40	0.51	e	1.27 BSC		
c	0.20	0.25	0.33	L	0.51	0.61	0.71
D	4.80	4.90	5.40	L1	--	--	0.15
D1	3.61	4.00	4.25	L2	0.41	0.51	0.61
E	5.65	5.80	6.06	θ	0°	--	12°