

Features

- Advanced high cell density Trench technology
- Super Low Gate Charge
- Excellent CdV/dt effect decline
- 100% EAS Guaranteed
- Green Device Available

Applications

- High Frequency Point-of-Load, Synchronous Buck Converter for MB/NB/UMPC/VGA
- Networking DC-DC Power System
- Load Switch

Product Summary



V_{DS}	-40	V
I_D	-52	A
$R_{DS(ON)}$ (at $V_{GS}=-10V$)	13	m Ω
$R_{DS(ON)}$ (at $V_{GS}=-4.5V$)	20	m Ω

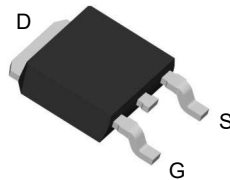

TO-252 Top View

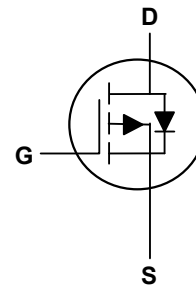

Absolute Maximum Ratings ($T_C=25^\circ\text{C}$, unless otherwise noted)

Parameter	Symbol	Rating	Units
Drain-Source Voltage	V_{DS}	-40	V
Gate-Source Voltage	V_{GS}	± 20	V
Continuous Drain Current, $V_{GS} @ -10V^1$	$I_D @ T_C=25^\circ\text{C}$	-52	A
Continuous Drain Current, $V_{GS} @ -10V^1$	$I_D @ T_C=100^\circ\text{C}$	-32	A
Continuous Drain Current, $V_{GS} @ -10V^1$	$I_D @ T_A=25^\circ\text{C}$	-10	A
Continuous Drain Current, $V_{GS} @ -10V^1$	$I_D @ T_A=70^\circ\text{C}$	-8	A
Pulsed Drain Current ²	I_{DM}	-105	A
Single Pulse Avalanche Energy ³	EAS	146	mJ
Avalanche Current	I_{AS}	-54	A
Total Power Dissipation ⁴	$P_D @ T_C=25^\circ\text{C}$	52.1	W
Total Power Dissipation ⁴	$P_D @ T_A=25^\circ\text{C}$	2	W
Storage Temperature Range	T_{STG}	-55 to 150	$^\circ\text{C}$
Operating Junction Temperature Range	T_J	-55 to 150	$^\circ\text{C}$

Thermal Characteristics

Parameter	Symbol	Typ	Max	Unit
Thermal Resistance Junction-Ambient ¹	$R_{\theta JA}$	---	62	$^\circ\text{C/W}$
Thermal Resistance Junction-Case ¹	$R_{\theta JC}$	---	2.4	$^\circ\text{C/W}$

Electrical Characteristics (T_J=25°C, unless otherwise noted)

Parameter	Symbol	Conditions	Min	Typ	Max	Unit
Drain-Source Breakdown Voltage	BV _{DSS}	V _{GS} =0V, I _D =-250uA	-40	---	---	V
BV _{DSS} Temperature Coefficient	ΔBV _{DSS} /ΔT _J	Reference to 25°C, I _D =-1mA	---	-0.023	---	V/°C
Static Drain-Source On-Resistance ²	R _{DS(ON)}	V _{GS} =-10V, I _D =-18A	---	10.5	13	mΩ
		V _{GS} =-4.5V, I _D =-12A	---	15	20	mΩ
Gate Threshold Voltage	V _{GS(th)}	V _{GS} =V _{DS} , I _D =-250uA	-1.0	-1.6	-2.5	V
V _{GS(th)} Temperature Coefficient	ΔV _{GS(th)}		---	4.74	---	mV/°C
Drain-Source Leakage Current	I _{DSS}	V _{DS} =-32V, V _{GS} =0V, T _J =25°C	---	---	1	uA
		V _{DS} =-32V, V _{GS} =0V, T _J =55°C	---	---	5	
Gate-Source Leakage Current	I _{GSS}	V _{GS} =±20V, V _{DS} =0V	---	---	±100	nA
Forward Transconductance	g _{fs}	V _{DS} =-5V, I _D =-18A	---	24	---	S
Gate Resistance	R _g	V _{DS} =0V, V _{GS} =0V, f=1MHz	---	7	14	Ω
Total Gate Charge (-4.5V)	Q _g	V _{DS} =-20V, V _{GS} =-4.5V, I _D =-12A	---	27.9	---	nC
Gate-Source Charge	Q _{gs}		---	7.7	---	
Gate-Drain Charge	Q _{gd}		---	7.5	---	
Turn-On Delay Time	T _{d(on)}	V _{DD} =-15V, V _{GS} =-10V, R _G =3.3Ω, I _D =-1A	---	40	---	ns
Rise Time	T _r		---	35.2	---	
Turn-Off Delay Time	T _{d(off)}		---	100	---	
Fall Time	T _f		---	9.6	---	
Input Capacitance	C _{iss}	V _{DS} =-15V, V _{GS} =0V, f=1MHz	---	3500	---	pF
Output Capacitance	C _{oss}		---	323	---	
Reverse Transfer Capacitance	C _{rss}		---	222	---	

Drain-Source Diode Characteristics

Parameter	Symbol	Conditions	Min	Typ	Max	Unit
Continuous Source Current ^{1,5}	I _S	V _G =V _D =0V, Force Current	---	---	-52	A
Pulsed Source Current ^{2,5}	I _{SM}		---	---	-105	A
Diode Forward Voltage ²	V _{SD}	V _{GS} =0V, I _S =-1A, T _J =25°C	---	---	-1	V

Note:

- The data tested by surface mounted on a 1 inch² FR-4 board with 20Z copper.
- The data tested by pulsed, pulse width ≤ 300us, duty cycle ≤ 2%
- The EAS data shows Max. rating. The test condition is V_{DD}=-25V, V_{GS}=-10V, L=0.1mH, I_{AS}=-54A
- The power dissipation is limited by 150°C junction temperature
- The data is theoretically the same as I_D and I_{DM}, in real applications, should be limited by total power dissipation.

Typical Characteristics

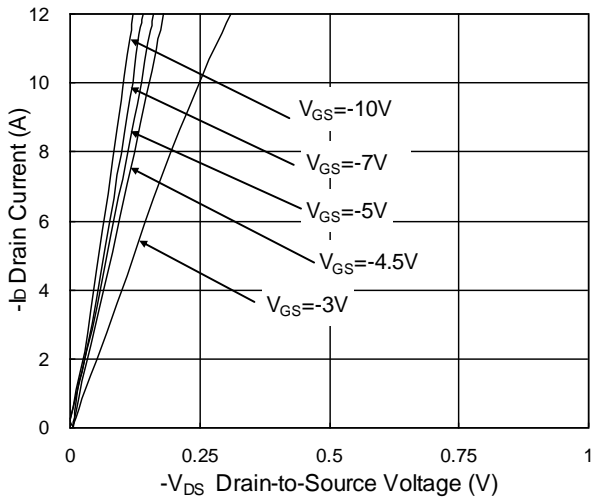

Fig.1 Typical Output Characteristics

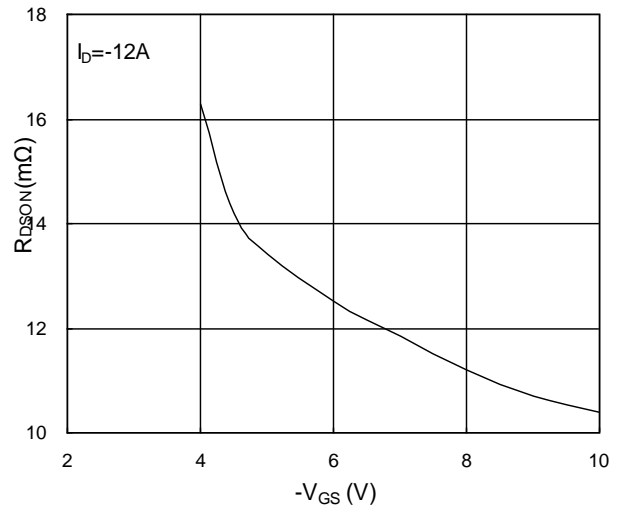

Fig.2 On-Resistance v.s Gate-Source

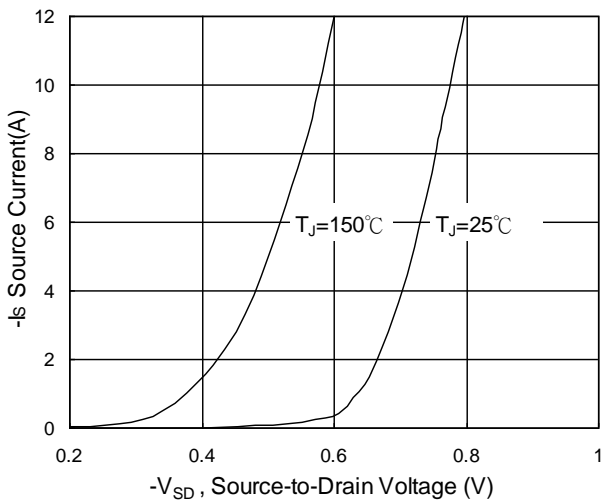

Fig.3 Forward Characteristics Of Reverse

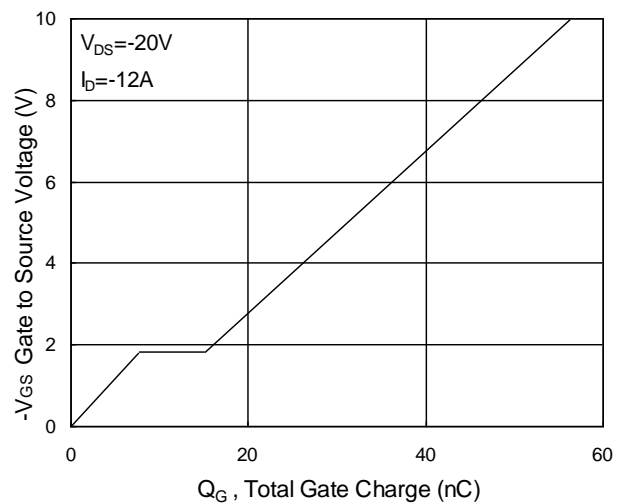

Fig.4 Gate-Charge Characteristics

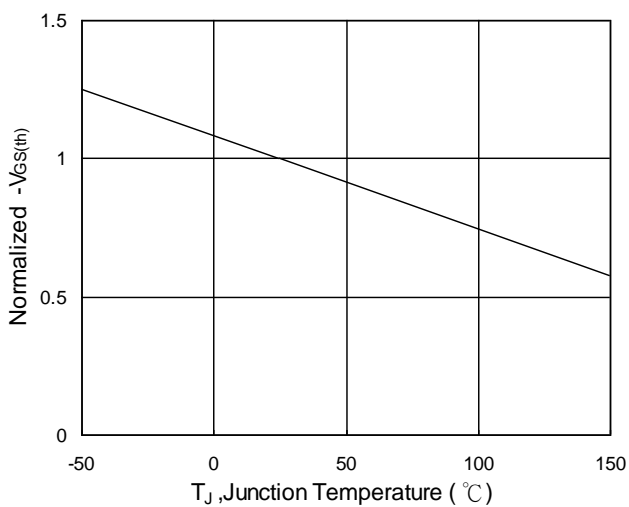

Fig.5 Normalized $V_{GS(th)}$ v.s T_J

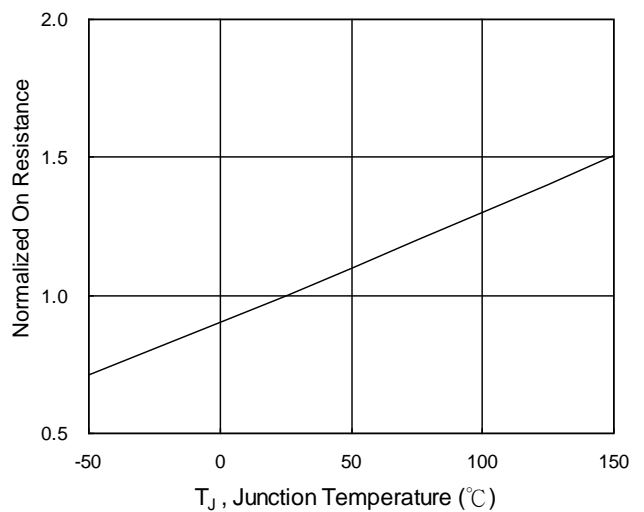

Fig.6 Normalized $R_{DS(on)}$ v.s T_J

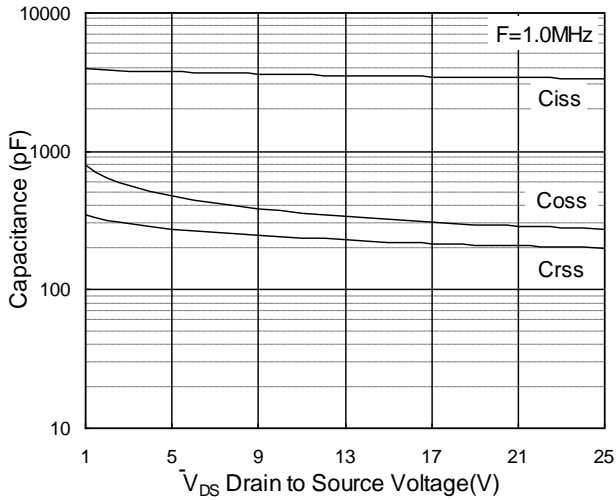

Fig.7 Capacitance

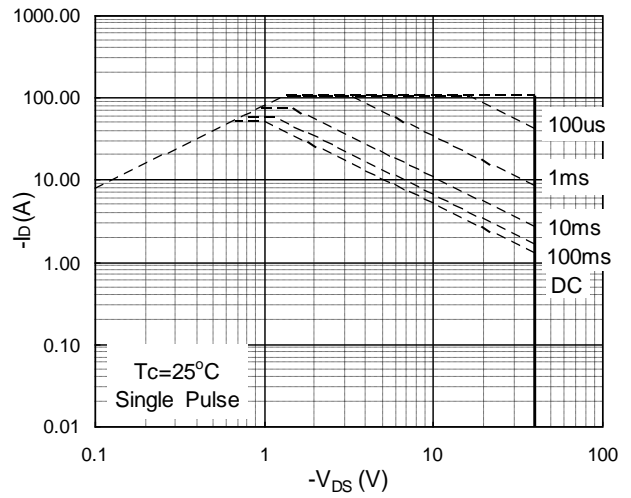

Fig.8 Safe Operating Area

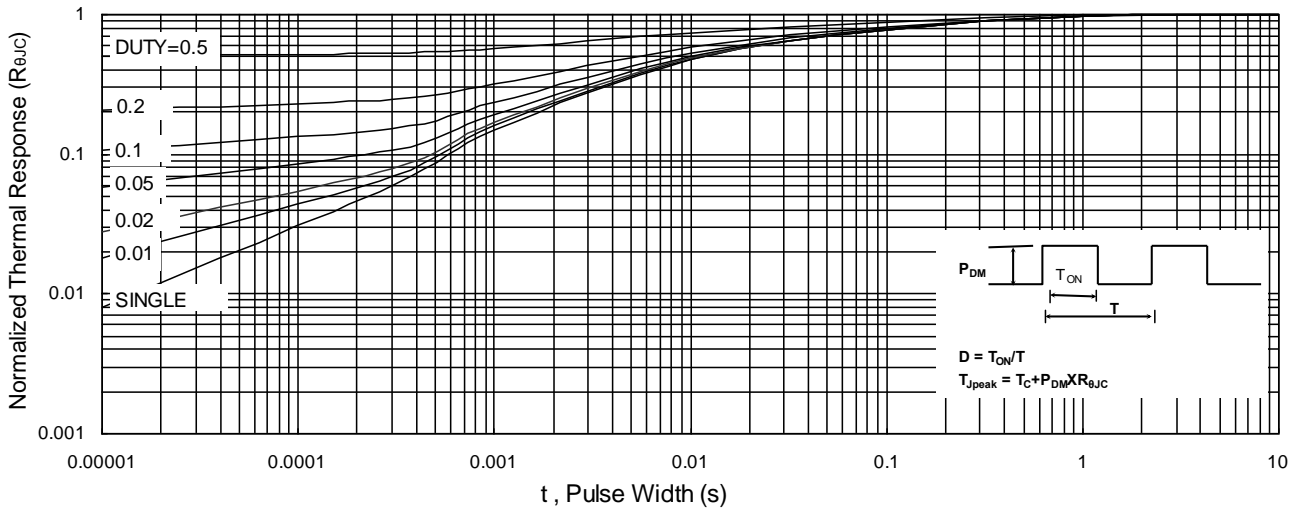

Fig.9 Normalized Maximum Transient Thermal Impedance

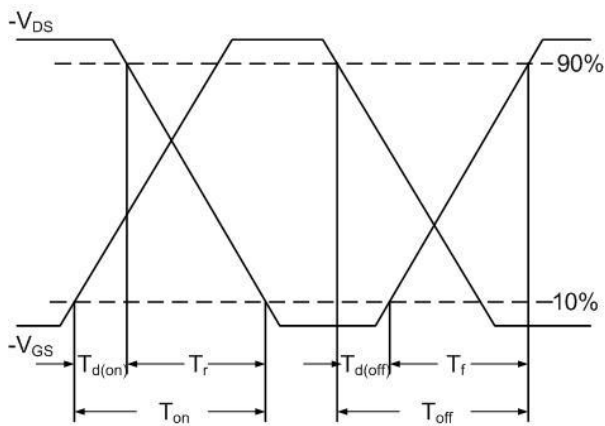

Fig.10 Switching Time Waveform

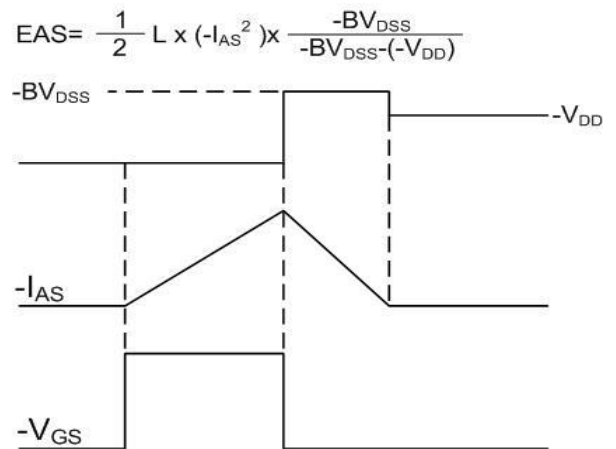
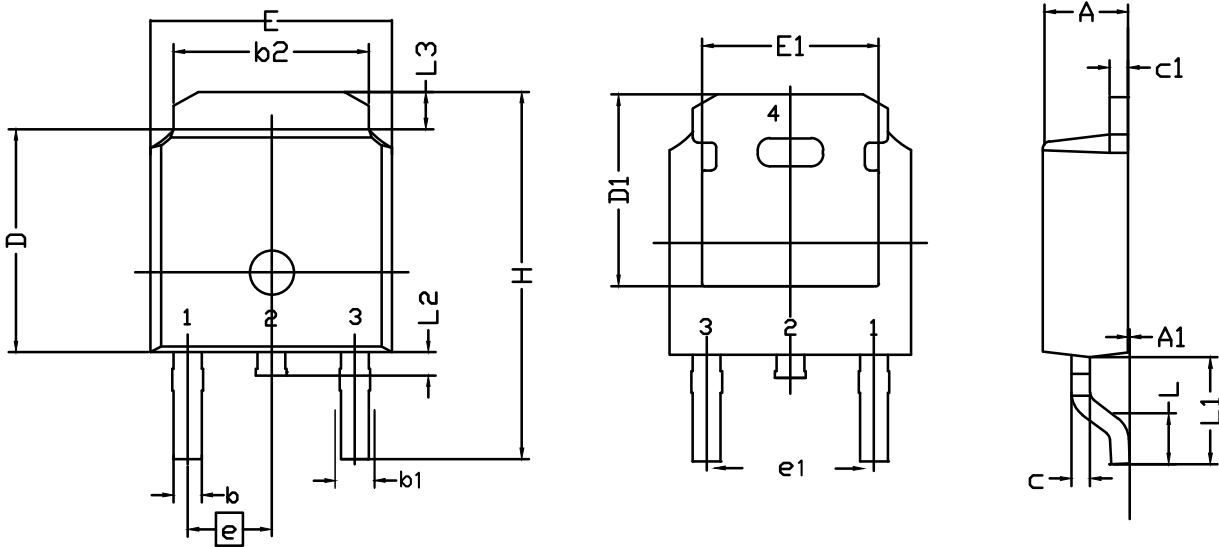

Fig.11 Unclamped Inductive Waveform

TO-252 Package Outline Dimensions



Symbol	Dimensions (unit:mm)			Symbol	Dimensions (unit:mm)		
	Min	Typ	Max		Min	Typ	Max
A	2.20	2.30	2.38	E	6.40	6.60	6.731
A₁	0.00	0.10	0.20	E₁	4.40	--	--
b	0.64	0.76	0.89	e	2.286 BSC		
b₁	0.77	0.85	1.14	e₁	4.572 BSC		
b₂	5.00	5.33	5.46	H	9.40	10.00	10.40
c	0.458	0.508	0.610	L	1.40	1.52	1.77
C₁	0.458	0.508	0.620	L₁	--	2.743	--
D	5.98	6.10	6.223	L₂	0.60	0.80	1.01
D₁	5.20	5.25	5.38	L₃	0.90	1.06	1.25