

Features

- Advanced high cell density Trench technology
- Super Low Gate Charge
- Excellent CdV/dt effect decline
- Green Device Available

Product Summary



V_{DS}	-40	V
I_D	-3.2	A
$R_{DS(ON)}$ (at $V_{GS}=-4.5V$)	70	m Ω
$R_{DS(ON)}$ (at $V_{GS}=-2.5V$)	100	m Ω

Applications

- High Frequency Point-of-Load, Synchronous Buck Converter for MB/NB/UMPC/VGA
- Networking DC-DC Power System
- Load Switch



Absolute Maximum Ratings ($T_C=25^{\circ}C$, unless otherwise noted)

Parameter	Symbol	Rating		Units
		10S	Steady State	
Drain-Source Voltage	V_{DS}	-40		V
Gate-Source Voltage	V_{GS}	± 20		V
Continuous Drain Current, $V_{GS} @ -4.5V^1$	$I_D @ T_A=25^{\circ}C$	-3.7	-3.2	A
Continuous Drain Current, $V_{GS} @ -4.5V^1$	$I_D @ T_A=70^{\circ}C$	-3.0	-2.6	A
Pulsed Drain Current ²	I_{DM}	-16.1		A
Total Power Dissipation ³	$P_D @ T_A=25^{\circ}C$	1.32	1	W
Total Power Dissipation ³	$P_D @ T_A=70^{\circ}C$	0.84	0.64	W
Storage Temperature Range	T_{STG}	-55 to 150		$^{\circ}C$
Operating Junction Temperature Range	T_J	-55 to 150		$^{\circ}C$

Thermal Characteristics

Parameter	Symbol	Typ	Max	Unit
Thermal Resistance Junction-Ambient ¹ ($t \leq 10s$)	$R_{\theta JA}$	---	95	$^{\circ}C/W$
Thermal Resistance Junction-Ambient ¹		---	125	$^{\circ}C/W$
Thermal Resistance Junction-Case ¹	$R_{\theta JC}$	---	80	$^{\circ}C/W$

Electrical Characteristics (T_J=25°C, unless otherwise noted)

Parameter	Symbol	Conditions	Min	Typ	Max	Unit
Drain-Source Breakdown Voltage	BV _{DSS}	V _{GS} =0V, I _D =-250uA	-40	---	---	V
BV _{DSS} Temperature Coefficient	ΔBV _{DSS} /ΔT _J	Reference to 25°C, I _D =-1mA	---	-0.018	---	V/°C
Static Drain-Source On-Resistance ²	R _{DS(ON)}	V _{GS} =-4.5V, I _D =-3A	---	---	70	mΩ
		V _{GS} =-2.5V, I _D =-2A	---	---	100	mΩ
Gate Threshold Voltage	V _{GS(th)}	V _{GS} =V _{DS} , I _D =-250uA	-1.0	---	-2.5	V
V _{GS(th)} Temperature Coefficient	ΔV _{GS(th)}		---	2.5	---	mV/°C
Drain-Source Leakage Current	I _{DSS}	V _{DS} =-24V, V _{GS} =0V, T _J =25°C	---	---	-1	uA
		V _{DS} =-24V, V _{GS} =0V, T _J =55°C	---	---	-5	uA
Gate-Source Leakage Current	I _{GSS}	V _{GS} =±20V, V _{DS} =0V	---	---	±100	nA
Forward Transconductance	g _{fs}	V _{DS} =-5V, I _D =-3A	---	5.8	---	S
Total Gate Charge (-4.5V)	Q _g	V _{DS} =-32V, V _{GS} =-4.5V, I _D =-3A	---	6.4	---	nC
Gate-Source Charge	Q _{gs}		---	2.1	---	
Gate-Drain Charge	Q _{gd}		---	2.5	---	
Turn-On Delay Time	T _{d(on)}	V _{DD} =-20V, V _{GS} =-4.5V, R _G =3.3Ω, I _D =-3A	---	4.2	---	ns
Rise Time	T _r		---	23	---	
Turn-Off Delay Time	T _{d(off)}		---	26.8	---	
Fall Time	T _f		---	20.6	---	
Input Capacitance	C _{iss}	V _{DS} =-15V, V _{GS} =0V, f=1MHz	---	620	---	pF
Output Capacitance	C _{oss}		---	65	---	
Reverse Transfer Capacitance	C _{rss}		---	53	---	

Drain-Source Diode Characteristics

Parameter	Symbol	Conditions	Min	Typ	Max	Unit
Continuous Source Current ^{1,4}	I _S	V _G =V _D =0V, Force Current	---	---	-3.2	A
Pulsed Source Current ^{2,4}	I _{SM}		---	---	-16.1	A
Diode Forward Voltage ²	V _{SD}	V _{GS} =0V, I _S =-1A, T _J =25°C	---	---	-1	V

Note:

- 1.The data tested by surface mounted on a 1 inch² FR-4 board with 2OZ copper.
- 2.The data tested by pulsed, pulse width ≤ 300us, duty cycle ≤ 2%
- 3.The power dissipation is limited by 150°C junction temperature
- 4.The data is theoretically the same as I_D and I_{DM}, in real applications, should be limited by total power dissipation.

Typical Characteristics

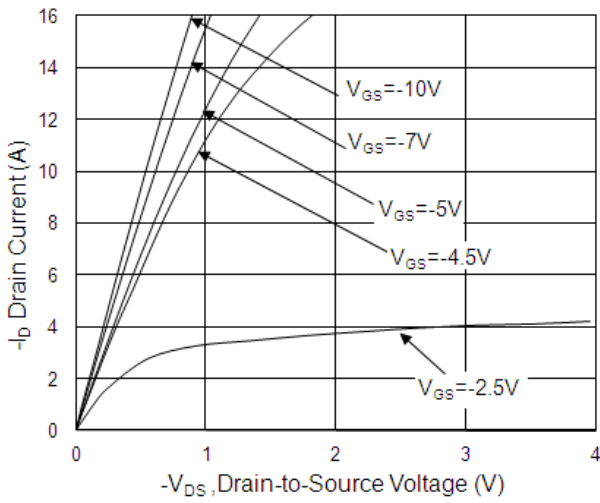

Fig.1 Typical Output Characteristics

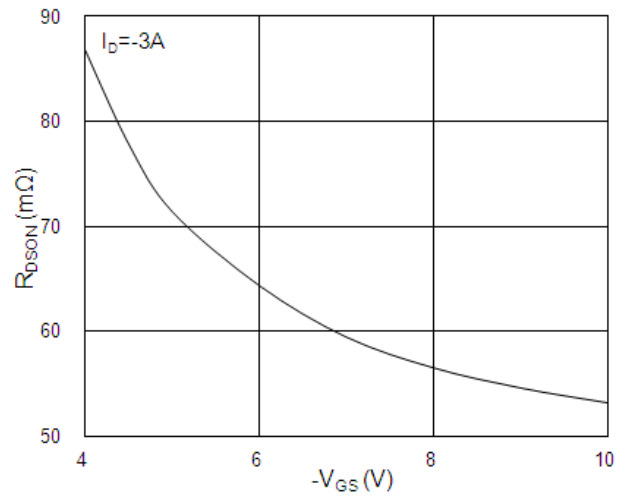

Fig.2 On-Resistance vs. G-S Voltage

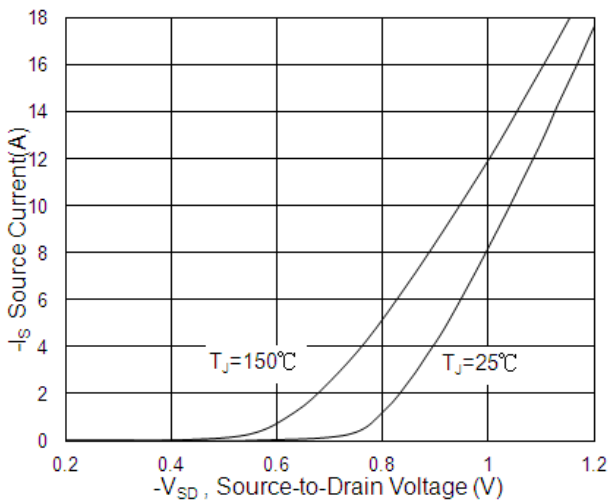

Fig.3 Forward Characteristics Of Reverse

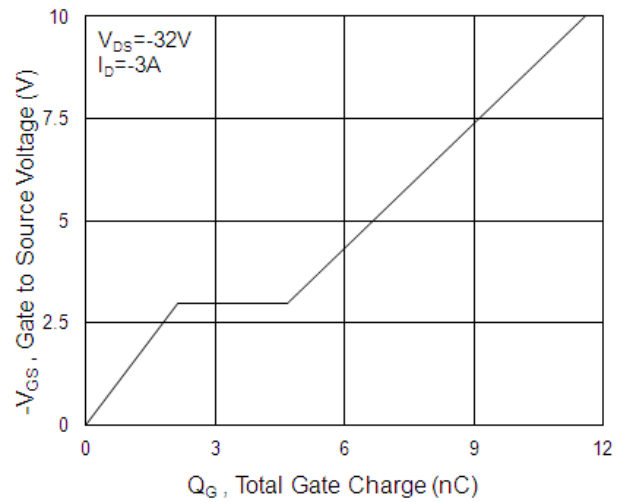

Fig.4 Gate-Charge Characteristics

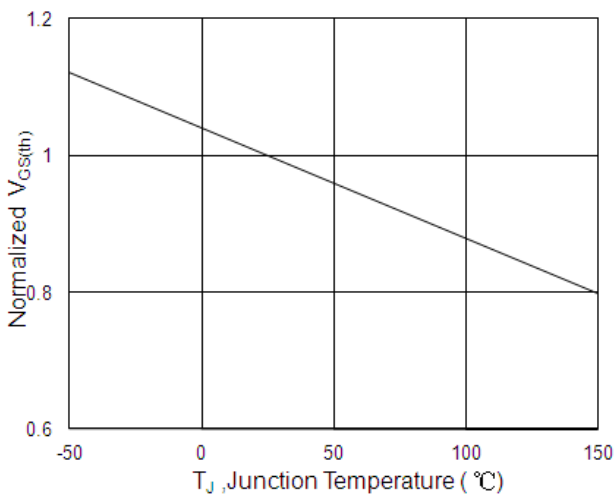

Fig.5 Normalized $V_{GS(th)}$ vs. T_J

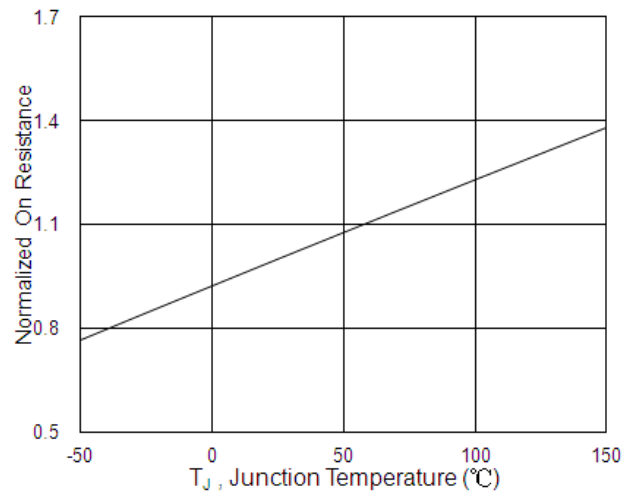

Fig.6 Normalized $R_{DS(on)}$ vs. T_J

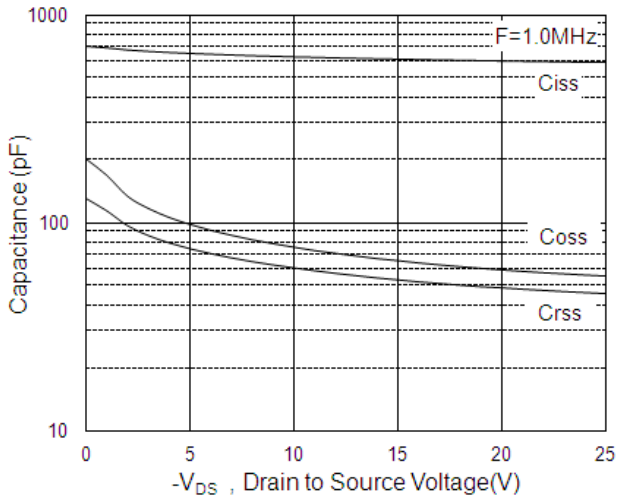

Fig.7 Capacitance

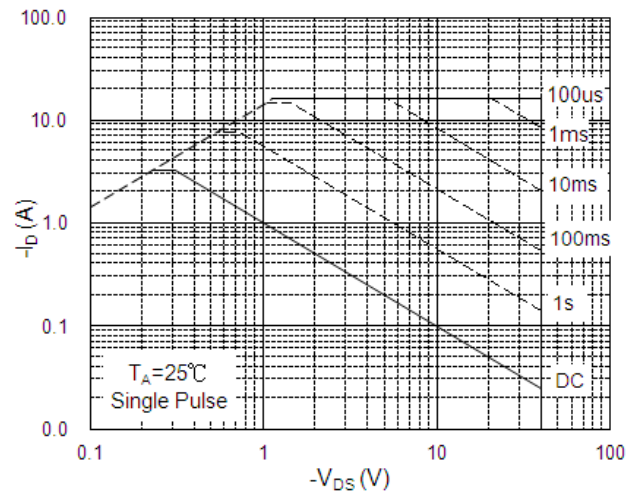

Fig.8 Safe Operating Area

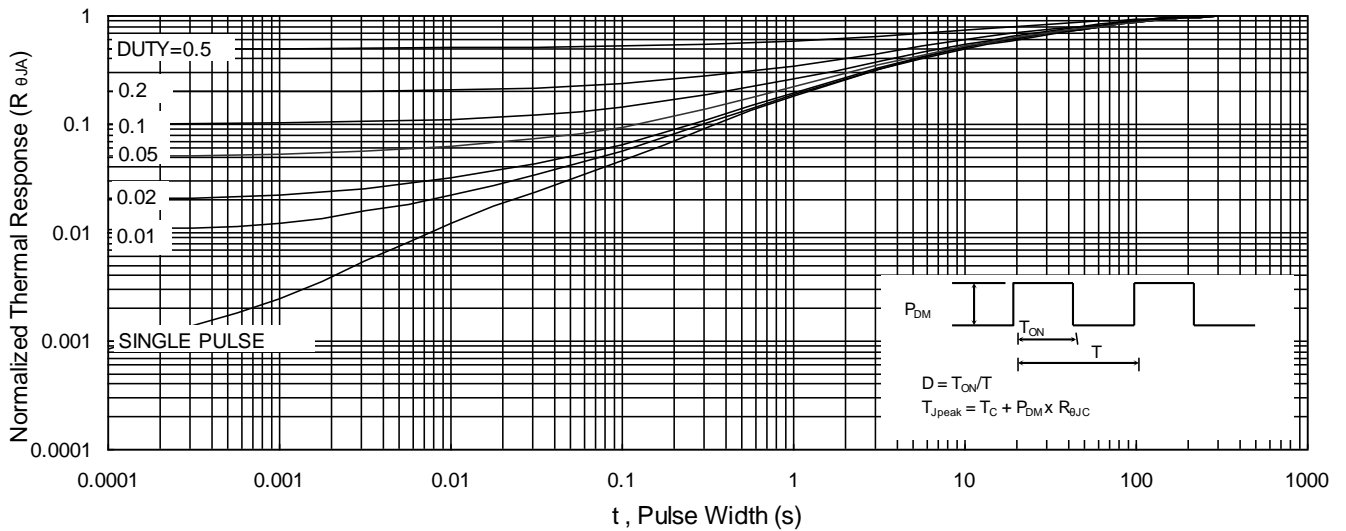

Fig.9 Normalized Maximum Transient Thermal Impedance

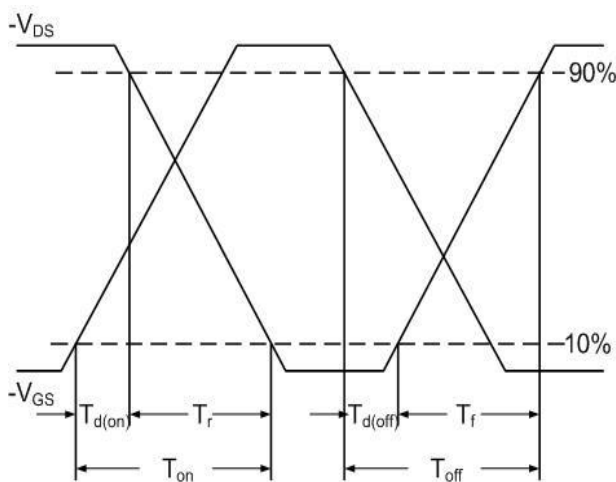

Fig.10 Switching Time Waveform

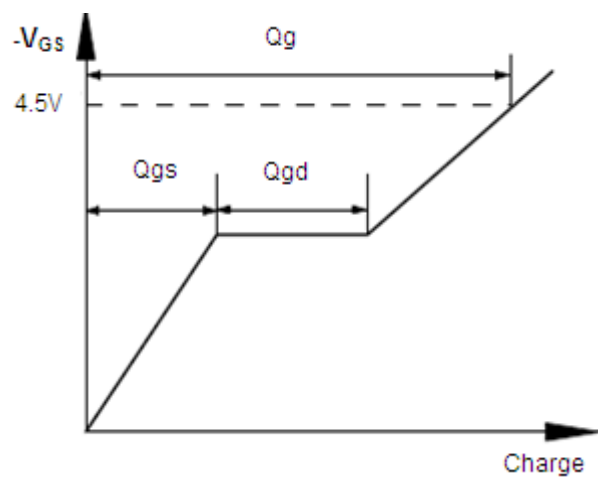

Fig.11 Gate Charge Waveform

SOT23-3L Package Outline Dimensions



Symbol	Dimensions (unit:mm)			Symbol	Dimensions (unit:mm)		
	Min	Typ	Max		Min	Typ	Max
A	0.90	1.07	1.25	e₁	--	0.95	--
A₁	0.01	0.05	0.10	H_E	2.50	2.80	3.00
b_p	0.30	0.40	0.50	L_p	0.30	0.45	0.60
c	0.10	0.15	0.20	Q	0.23	0.28	0.33
D	2.70	2.90	3.10	V	--	0.20	--
E	1.40	1.55	1.75	W	--	0.20	--
e	--	1.90	--				