

### Features

- Low drain-source on-resistance:  $R_{DS(ON)}=0.555\Omega(\text{typ})$
- Easy to control gate switching
- Enhancement mode:  $V_{th} = 2.0$  to  $4.0V$
- 100% avalanche tested
- Built-in ESD Diode
- RoHS compliant

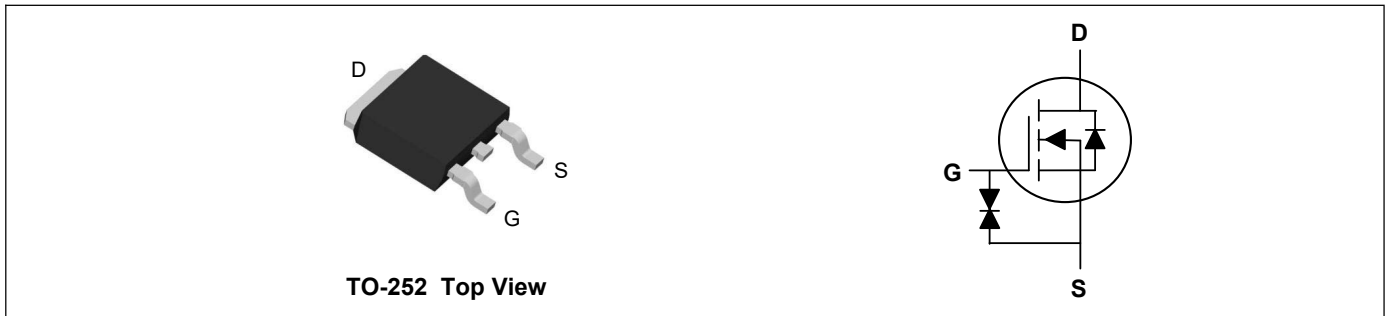
### Key Performance Parameters



Parameter	Value	Unit
$V_{DS} @ T_{j,max}$	650	V
$R_{DS(ON),max}$	640	m $\Omega$
$I_D$	6.7	A
$Q_{g,typ}$	14	nC
$I_{DM}$	20	A

### Applications

- Switch Mode Power Supply (SMPS)
- TV power & LED Lighting Power
- AC to DC Converters
- Telecom



### Absolute Maximum Ratings( $T_C=25^\circ C$ , unless otherwise noted)

Parameter	Symbol	Value	Unit
Drain-Source Voltage	$V_{DS}$	650	V
Gate-Source Voltage	$V_{GS}$	$\pm 20$	V
Continuous Drain Current <sup>1</sup>	$I_D @ T_C=25^\circ C$	6.7	A
Continuous Drain Current <sup>1</sup>	$I_D @ T_C=100^\circ C$	4.2	A
Pulsed Drain Current <sup>2</sup>	$I_{DM}$	20	A
Single Pulse Avalanche Energy <sup>4</sup>	EAS	73	mJ
Avalanche Current	$I_{AS}$	1.3	A
MOSFET dv/dt ruggedness, $V_{DS} = 0 \dots 400V$	dv/dt	50	V/ns
Reverse diode dv/dt <sup>3</sup> $V_{DS}=0 \dots 400V, I_{DS} \leq I_D$		15	
Total Power Dissipation ( $T_C=25^\circ C$ )	$P_D$	37	W
Gate source ESD(HBM-C=100pF, R=1.5K $\Omega$ )	$V_{ESD(G-S)}$	2000	V
Storage Temperature Range	$T_{STG}$	-55 to 150	$^\circ C$
Operating Junction Temperature Range	$T_J$	-55 to 150	$^\circ C$

### Thermal Characteristics

Parameter	Symbol	Value	Unit
Thermal Resistance Junction-Ambient (Max)	$R_{\theta JA}$	62.5	$^\circ C/W$
Thermal Resistance Junction-Case (Max)	$R_{\theta JC}$	3.4	$^\circ C/W$

**Electrical Characteristics ( $T_J=25^\circ\text{C}$ , unless otherwise noted)**

Parameter	Symbol	Conditions	Min	Typ	Max	Unit
Drain-Source Breakdown Voltage	$BV_{DSS}$	$V_{GS}=0V, I_D=1mA$	650	---	---	V
Static Drain-Source On-Resistance	$R_{DS(ON)}$	$V_{GS}=10V, I_D=2A$	---	555	640	m $\Omega$
Gate Threshold Voltage	$V_{GS(th)}$	$V_{GS}=V_{DS}, I_D=220\mu A$	2.0	---	4.0	V
Drain-Source Leakage Current	$I_{DSS}$	$V_{DS}=650V, V_{GS}=0V, T_J=25^\circ\text{C}$	---	---	1	$\mu A$
		$V_{DS}=650V, V_{GS}=0V, T_J=150^\circ\text{C}$	---	---	100	$\mu A$
Gate-Source Leakage Current	$I_{GSS}$	$V_{GS}=\pm 20V, V_{DS}=0V$	---	---	$\pm 1$	$\mu A$
Total Gate Charge	$Q_g$	$V_{DS}=520V, V_{GS}=10V, I_D=2.9A$	---	14	---	nC
Gate-Source Charge	$Q_{gs}$		---	2.6	---	
Gate-Drain Charge	$Q_{gd}$		---	4.5	---	
Turn-On Delay Time	$T_{d(on)}$	$V_{DS}=325V, R_G=25\Omega, I_D=2.9A$	---	23	---	ns
Rise Time	$T_r$		---	18	---	
Turn-Off Delay Time	$T_{d(off)}$		---	77	---	
Fall Time	$T_f$		---	18	---	
Input Capacitance	$C_{iss}$	$V_{DS}=400V, V_{GS}=0V, f=1MHz$	---	588	---	$\mu F$
Output Capacitance	$C_{oss}$		---	17	---	
Reverse Transfer Capacitance	$C_{rss}$		---	2.7	---	

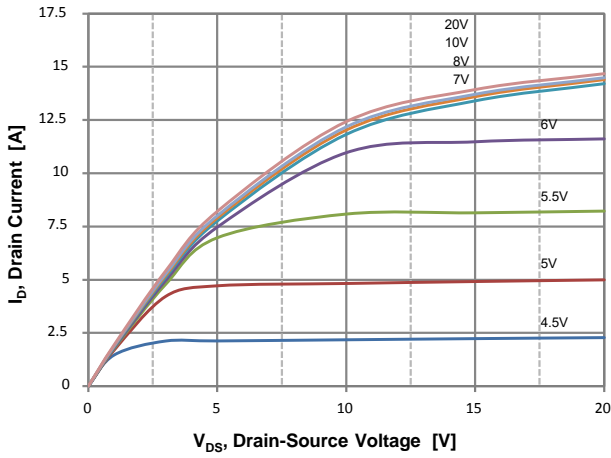
**Drain-Source Diode Characteristics**

Parameter	Symbol	Conditions	Min	Typ	Max	Unit
Continuous Source Current	$I_S$	$T_C=25^\circ\text{C}$	---	---	6.7	A
Pulsed Source Current	$I_{SM}$		---	---	20	A
Diode Forward Voltage	$V_{SD}$	$V_G=0V, I_S=2.9A, T_J=25^\circ\text{C}$	---	---	1.3	V
Reverse Recovery Time	$t_{rr}$	$V_R=400V, I_F=2.9A, di_F/dt=100A/\mu s$	---	250	---	ns
Reverse Recovery Charge	$Q_{rr}$		---	1.8	---	$\mu C$

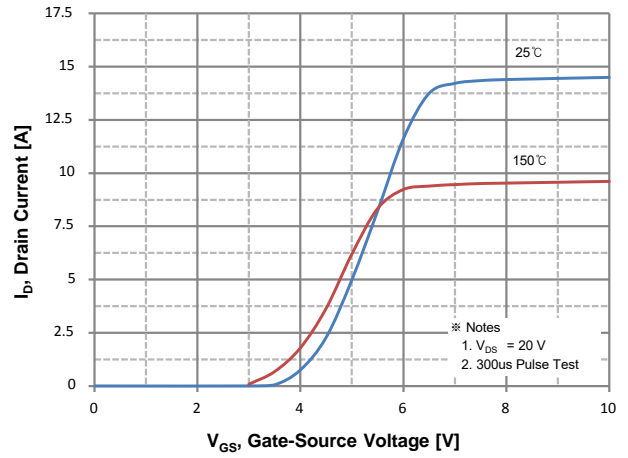
**Note:**

- Limited by  $T_{J,max}$ . Maximum Duty Cycle  $D = 0.50$
- Pulse width  $t_p$  limited by  $T_{J,max}$
- Identical low side and high side switch with identical  $R_G$
- $V_{DD}=50V, R_G=25\Omega, I_{AS}=1.3A$

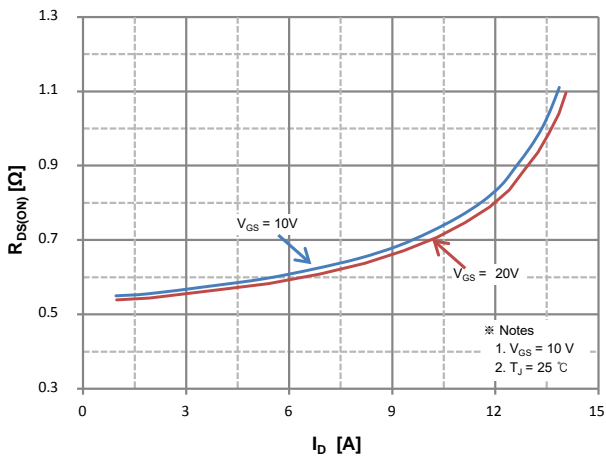
**Typical Characteristics**



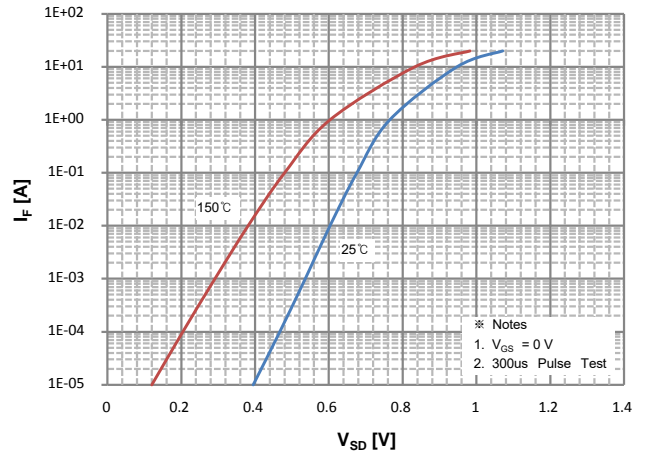
**Figure 1. On Region Characteristics**



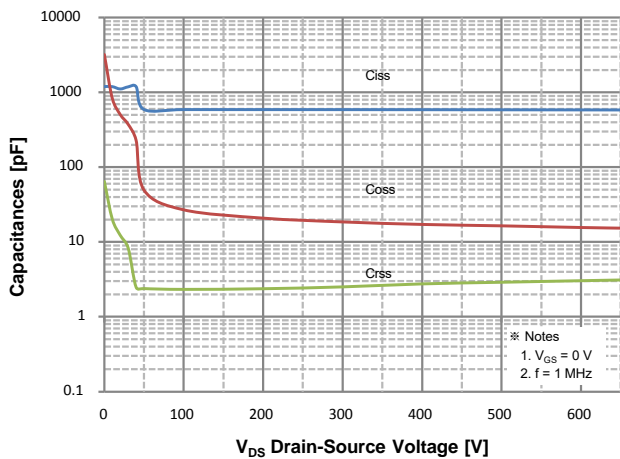
**Figure 2. Transfer Characteristics**



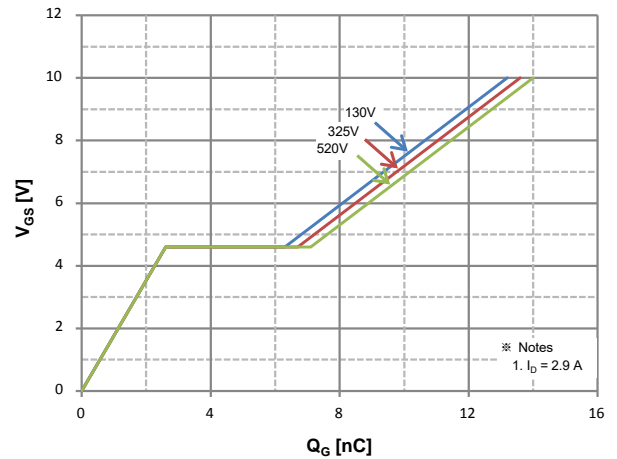
**Figure 3. On Resistance Variation vs Drain Current and Gate Voltage**



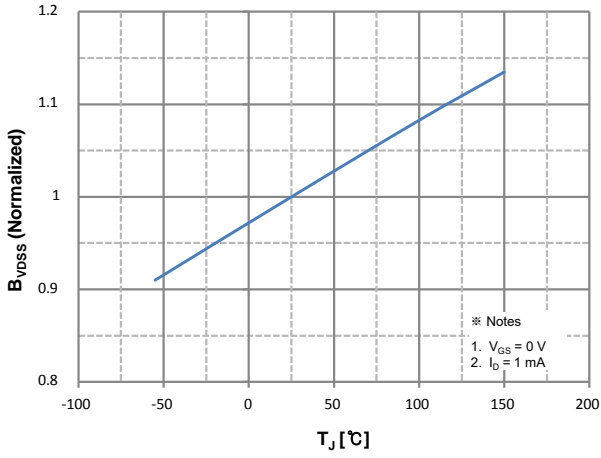
**Figure 4. Body Diode Forward Voltage Variation with Source Current and Temperature**



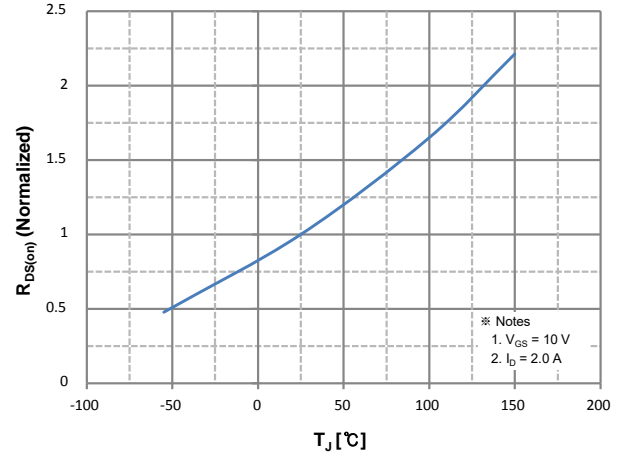
**Figure 5. Capacitance Characteristics**



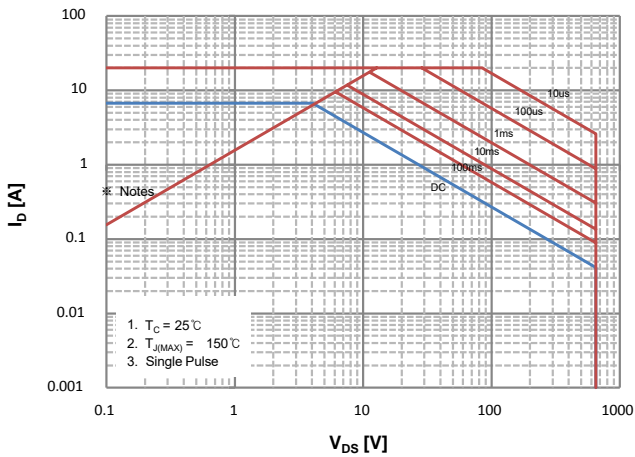
**Figure 6. Gate Charge Characteristics**



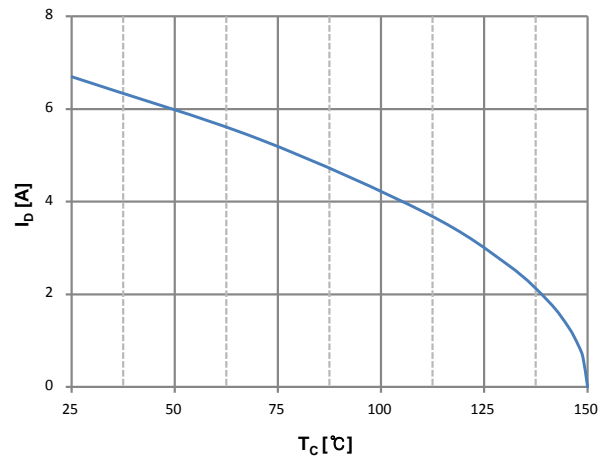
**Figure 7. Breakdown Voltage Variation vs. Temperature**



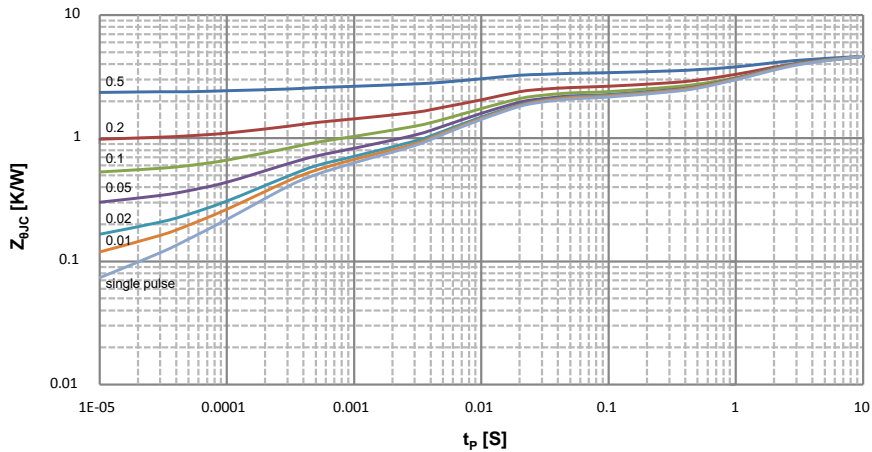
**Figure 8. On-Resistance Variation vs. Temperature**



**Figure 9. Maximum Safe Operating Area**

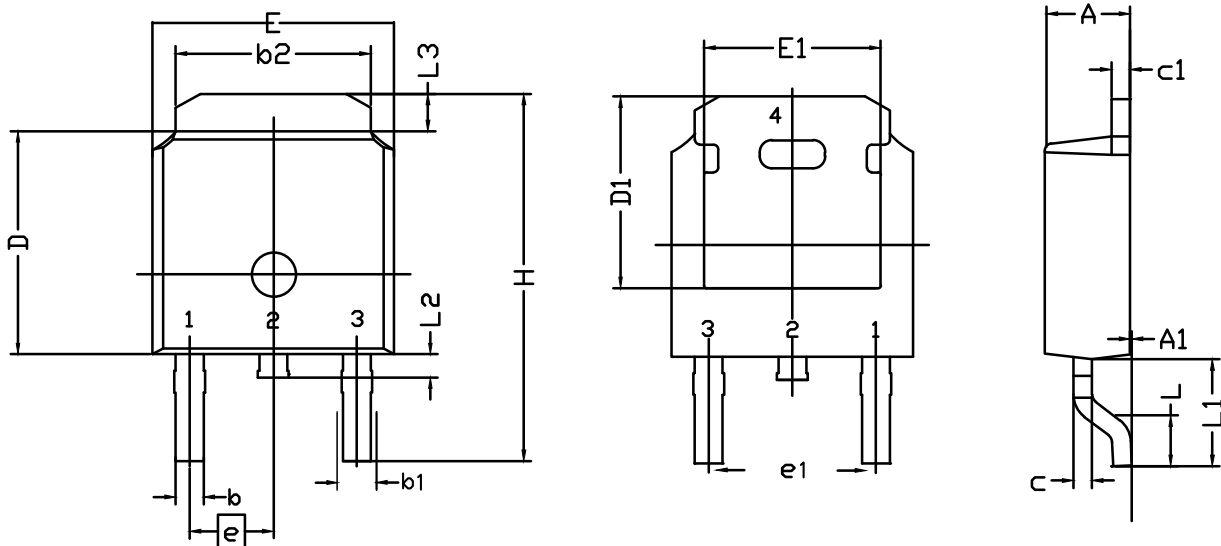


**Figure 10. Maximum Drain Current vs. Case Temperature**



**Figure 11. Transient Thermal Response Curve**

**TO-252 Package Outline Dimensions**



Symbol	Dimensions (unit:mm)			Symbol	Dimensions (unit:mm)		
	Min	Typ	Max		Min	Typ	Max
<b>A</b>	2.20	2.30	2.38	<b>E</b>	6.40	6.60	6.731
<b>A<sub>1</sub></b>	0.00	0.10	0.20	<b>E<sub>1</sub></b>	4.40	--	--
<b>b</b>	0.64	0.76	0.89	<b>e</b>	2.286 BSC		
<b>b<sub>1</sub></b>	0.77	0.85	1.14	<b>e<sub>1</sub></b>	4.572 BSC		
<b>b<sub>2</sub></b>	5.00	5.33	5.46	<b>H</b>	9.40	10.00	10.40
<b>c</b>	0.458	0.508	0.610	<b>L</b>	1.40	1.52	1.77
<b>C<sub>1</sub></b>	0.458	0.508	0.620	<b>L<sub>1</sub></b>	--	2.743	--
<b>D</b>	5.98	6.10	6.223	<b>L<sub>2</sub></b>	0.60	0.80	1.01
<b>D<sub>1</sub></b>	5.20	5.25	5.38	<b>L<sub>3</sub></b>	0.90	1.06	1.25