

**Features**

- Advanced high cell density Trench technology
- Super Low Gate Charge
- Excellent CdV/dt effect decline
- 100% EAS Guaranteed
- Green Device Available

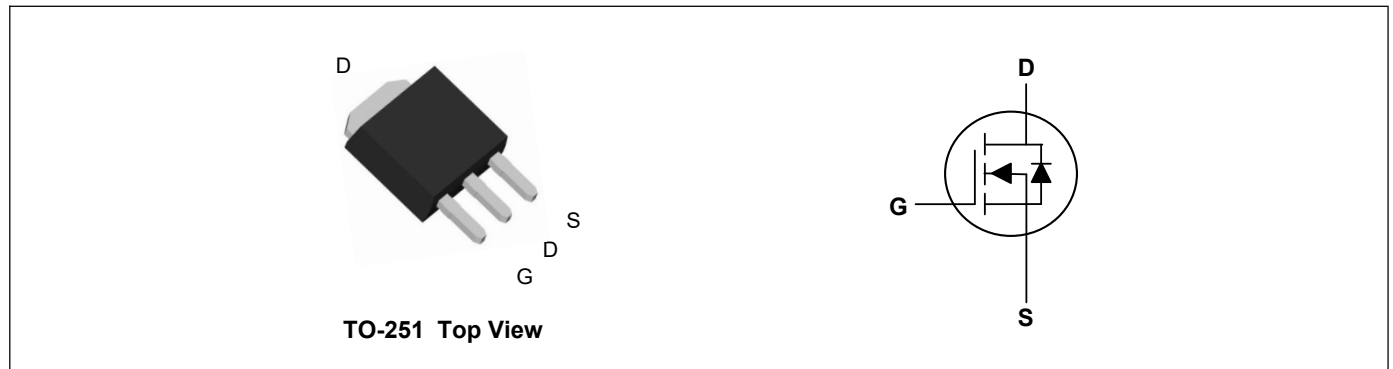
**Product Summary**



$V_{DS}$	100	V
$I_D$	73	A
$R_{DS(ON)}$ (at $V_{GS}=10V$ )	8.5	m $\Omega$
$R_{DS(ON)}$ (at $V_{GS}=4.5V$ )	11	m $\Omega$

**Applications**

- High Frequency Point-of-Load Synchronous Buck Converter
- Networking DC-DC Power System
- Power Tool Application, AC/DC Quick Charger



**Absolute Maximum Ratings( $T_C=25^{\circ}C$ , unless otherwise noted)**

Parameter	Symbol	Rating	Units
Drain-Source Voltage	$V_{DS}$	100	V
Gate-Source Voltage	$V_{GS}$	$\pm 20$	V
Continuous Drain Current <sup>1</sup>	$I_D@T_C=25^{\circ}C$	73	A
Continuous Drain Current <sup>1</sup>	$I_D@T_C=70^{\circ}C$	46	A
Pulsed Drain Current <sup>2</sup>	$I_{DM}$	290	A
Single Pulse Avalanche Energy <sup>3</sup>	EAS	61	mJ
Avalanche Current	$I_{AS}$	35	A
Total Power Dissipation <sup>4</sup>	$P_D@T_C=25^{\circ}C$	108	W
Storage Temperature Range	$T_{STG}$	-55 to 150	$^{\circ}C$
Operating Junction Temperature Range	$T_J$	-55 to 150	$^{\circ}C$

**Thermal Characteristics**

Parameter	Symbol	Typ	Max	Unit
Thermal Resistance Junction-Ambient <sup>1</sup> ( $t \leq 10s$ )	$R_{\theta JA}$	---	25	$^{\circ}C/W$
Thermal Resistance Junction-Ambient <sup>1</sup>		---	55	$^{\circ}C/W$
Thermal Resistance Junction-Case <sup>1</sup>	$R_{\theta JC}$	---	1.15	$^{\circ}C/W$

**Electrical Characteristics (T<sub>J</sub>=25°C, unless otherwise noted)**

Parameter	Symbol	Conditions	Min	Typ	Max	Unit
Drain-Source Breakdown Voltage	BV <sub>DSS</sub>	V <sub>GS</sub> =0V, I <sub>D</sub> =250uA	100	---	---	V
Static Drain-Source On-Resistance <sup>2</sup>	R <sub>DS(ON)</sub>	V <sub>GS</sub> =10V, I <sub>D</sub> =13.5A	---	6.6	8.5	mΩ
		V <sub>GS</sub> =4.5V, I <sub>D</sub> =11.5A	---	8.7	11	mΩ
Gate Threshold Voltage	V <sub>GS(th)</sub>	V <sub>GS</sub> =V <sub>DS</sub> , I <sub>D</sub> =250uA	1.2	---	2.3	V
Drain-Source Leakage Current	I <sub>DSS</sub>	V <sub>DS</sub> =80V, V <sub>GS</sub> =0V, T <sub>J</sub> =25°C	---	---	1	uA
		V <sub>DS</sub> =80V, V <sub>GS</sub> =0V, T <sub>J</sub> =55°C	---	---	5	
Gate-Source Leakage Current	I <sub>GSS</sub>	V <sub>GS</sub> =±20V, V <sub>DS</sub> =0V	---	---	±100	nA
Forward Transconductance	g <sub>fs</sub>	V <sub>DS</sub> =5V, I <sub>D</sub> =20A	---	85	---	S
Total Gate Charge (10V)	Q <sub>g</sub>	V <sub>DS</sub> =50V, V <sub>GS</sub> =10V, I <sub>D</sub> =13.5A	---	45	---	nC
Total Gate Charge (4.5V)	Q <sub>g</sub>		---	19.3	---	
Gate-Source Charge	Q <sub>gs</sub>		---	9.5	---	
Gate-Drain Charge	Q <sub>gd</sub>		---	4.8	---	
Turn-On Delay Time	T <sub>d(on)</sub>	V <sub>DD</sub> =50V, V <sub>GS</sub> =10V, R <sub>G</sub> =3Ω, I <sub>D</sub> =13.5A	---	10	---	ns
Rise Time	T <sub>r</sub>		---	6.5	---	
Turn-Off Delay Time	T <sub>d(off)</sub>		---	45	---	
Fall Time	T <sub>f</sub>		---	7.5	---	
Input Capacitance	C <sub>iss</sub>	V <sub>DS</sub> =50V, V <sub>GS</sub> =0V, f=1MHz	---	3320	---	pF
Output Capacitance	C <sub>oss</sub>		---	605	---	
Reverse Transfer Capacitance	C <sub>rss</sub>		---	20	---	

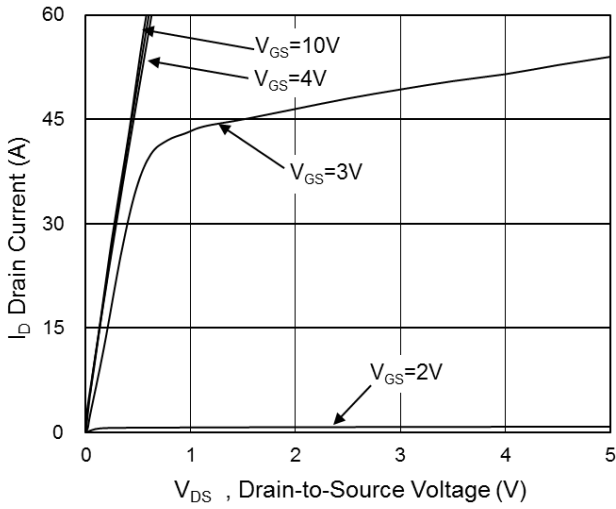
**Drain-Source Diode Characteristics**

Parameter	Symbol	Conditions	Min	Typ	Max	Unit
Continuous Source Current <sup>1,5</sup>	I <sub>S</sub>	V <sub>G</sub> =V <sub>D</sub> =0V, Force Current	---	---	48	A
Diode Forward Voltage <sup>2</sup>	V <sub>SD</sub>	V <sub>GS</sub> =0V, I <sub>S</sub> =1A, T <sub>J</sub> =25°C	---	---	1.1	V
Reverse Recovery Time	t <sub>rr</sub>	I <sub>F</sub> =13.5A, di/dt=100A/μs, T <sub>J</sub> =25°C	---	33	---	nS
Reverse Recovery Charge	Q <sub>rr</sub>		---	150	---	nC

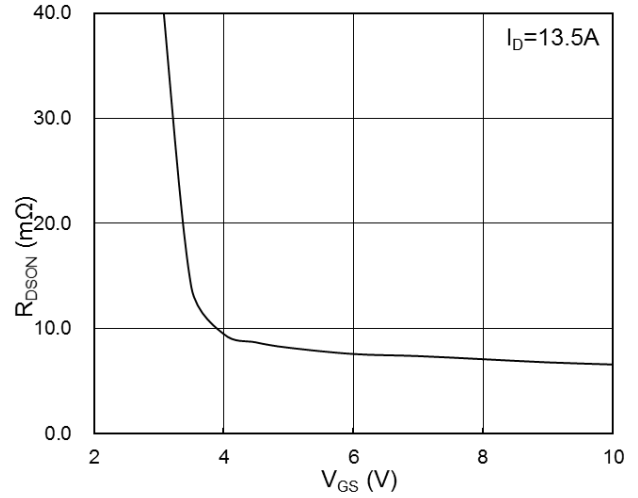
**Note:**

- 1.The data tested by surface mounted on a 1 inch<sup>2</sup> FR-4 board with 2OZ copper.
- 2.The data tested by pulsed, pulse width ≤ 300us, duty cycle ≤ 2%
- 3.The EAS data shows Max. rating. The test condition is V<sub>DD</sub>=25V, V<sub>GS</sub>=10V, L=0.3mH
- 4.The power dissipation is limited by 150°C junction temperature
- 5.The data is theoretically the same as I<sub>D</sub> and I<sub>DM</sub>, in real applications, should be limited by total power dissipation.

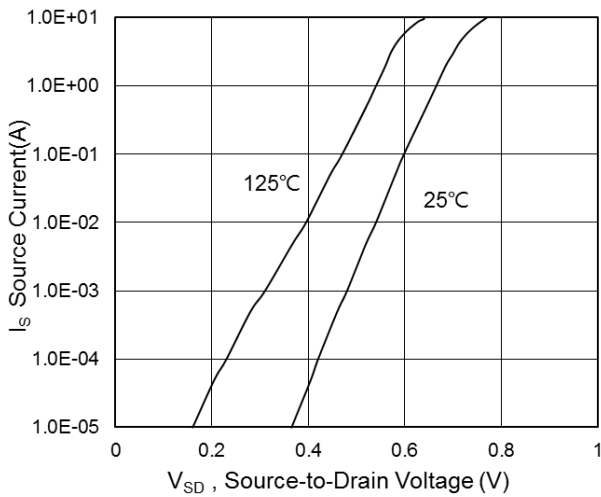
**Typical Characteristics**



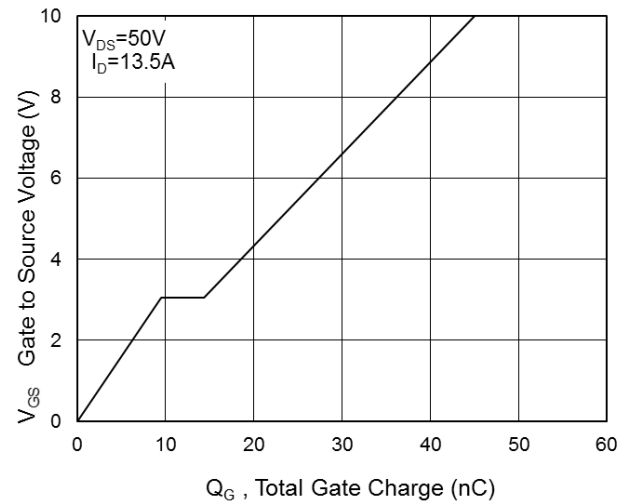
**Fig.1 Typical Output Characteristics**



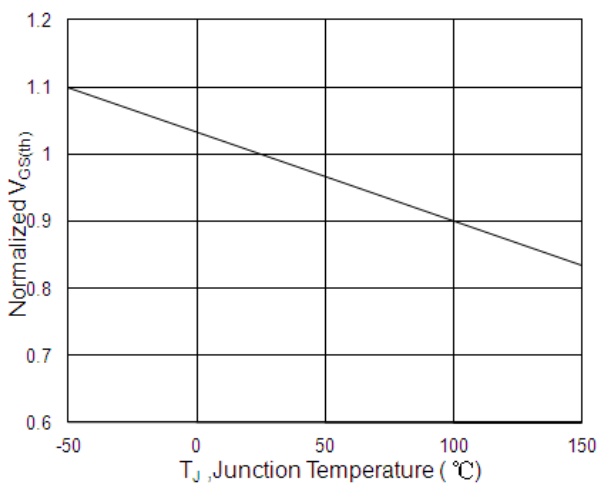
**Fig.2 On-Resistance vs G-S Voltage**



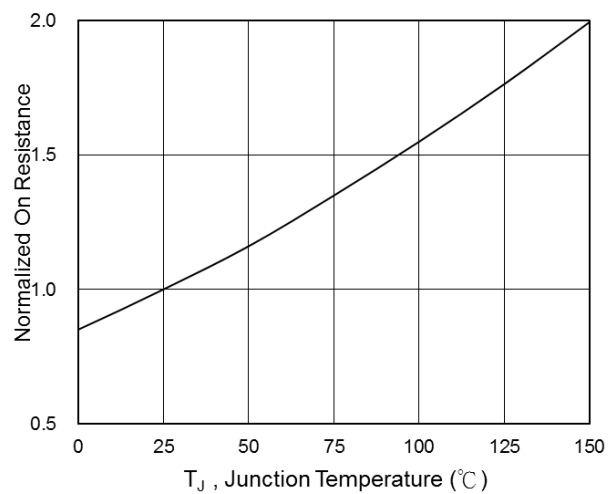
**Fig.3 Source-Drain Forward Characteristics**



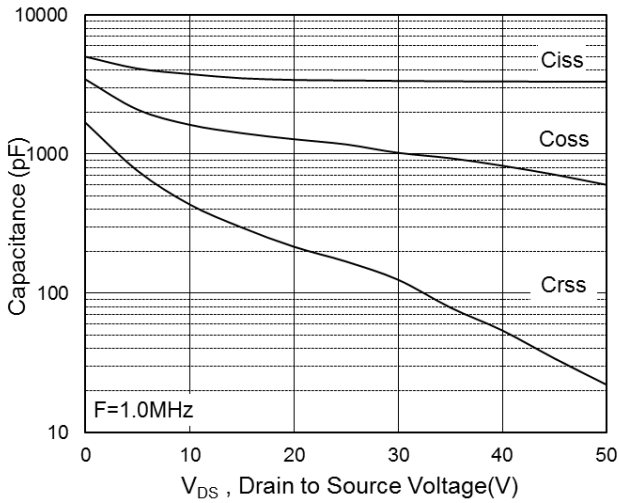
**Fig.4 Gate-Charge Characteristics**



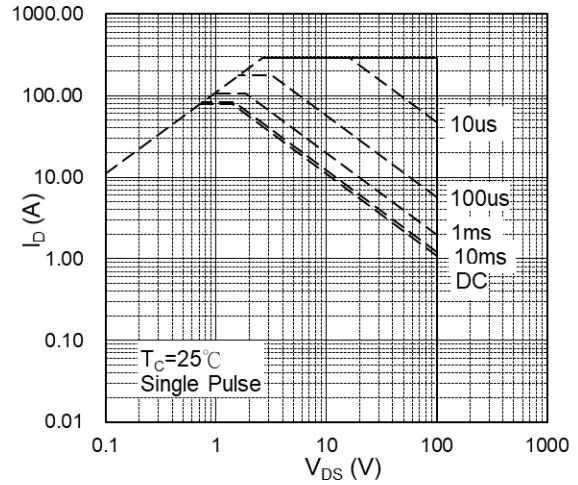
**Fig.5 Normalized  $V_{GS(th)}$  vs  $T_J$**



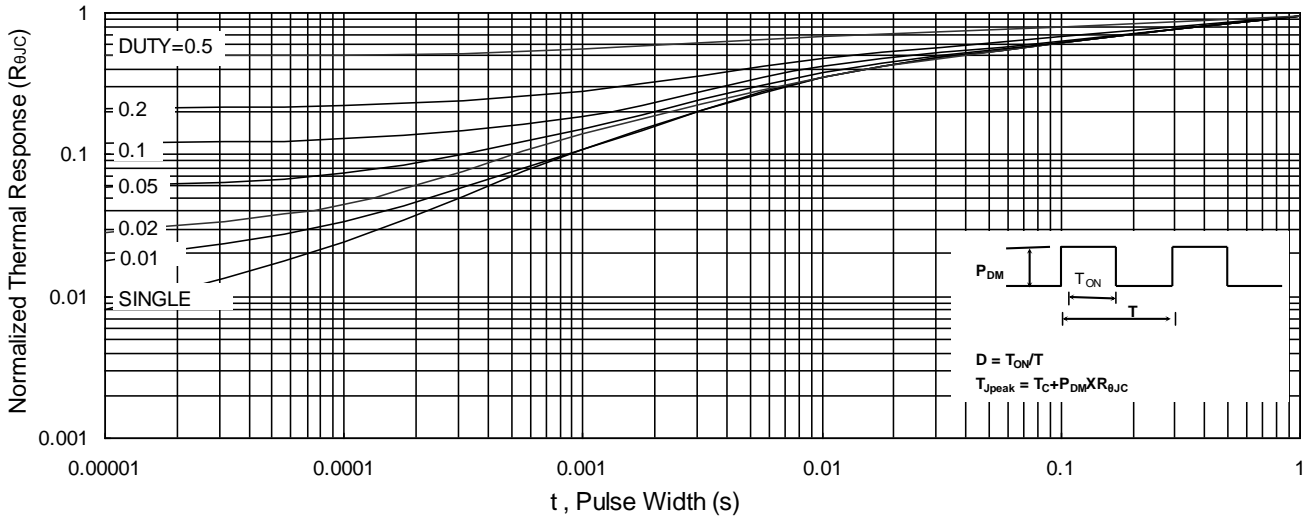
**Fig.6 Normalized  $R_{DSON}$  vs  $T_J$**



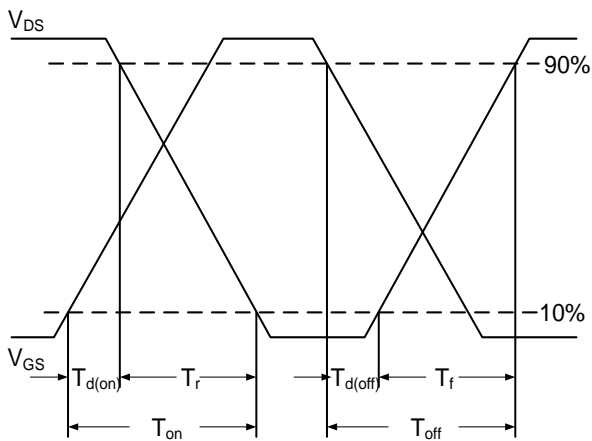
**Fig.7 Capacitance**



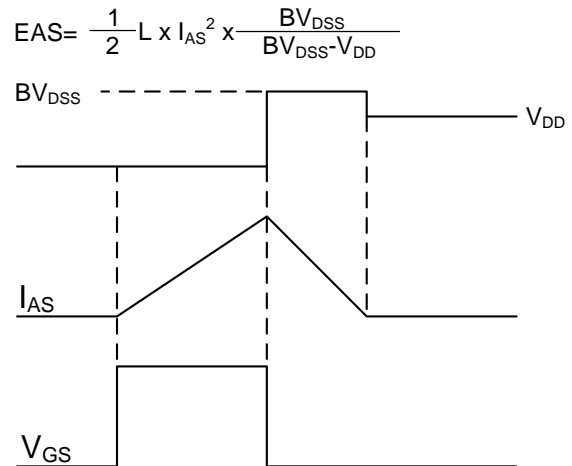
**Fig.8 Safe Operating Area**



**Fig.9 Normalized Maximum Transient Thermal Impedance**

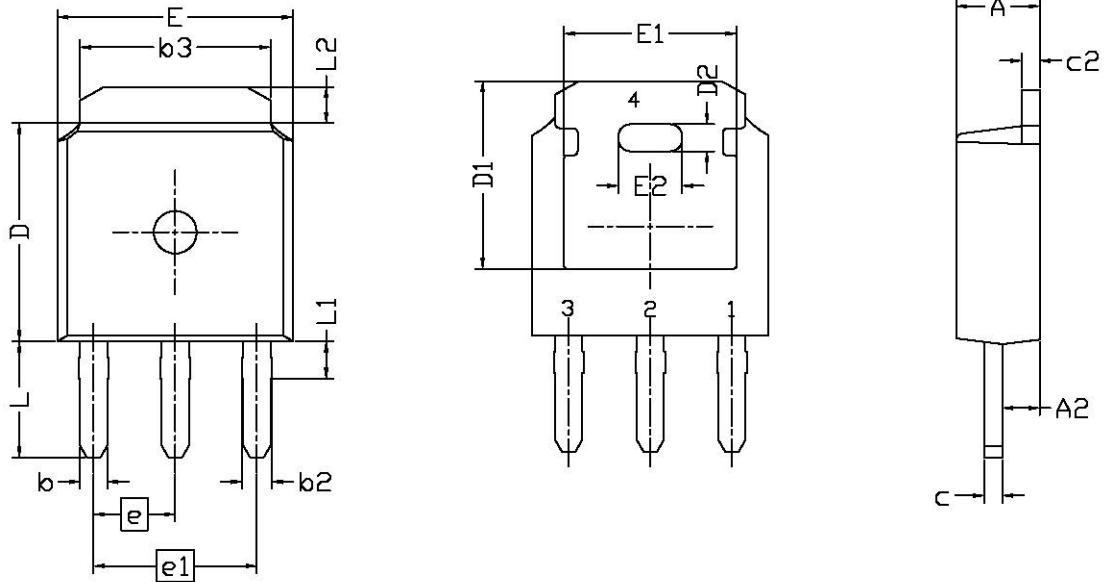


**Fig.10 Switching Time Waveform**



**Fig.11 Unclamped Inductive Switching Waveform**

**TO-251 Package Outline Dimensions**



Symbol	Dimensions (unit:mm)			Symbol	Dimensions (unit:mm)		
	Min	Typ	Max		Min	Typ	Max
<b>A</b>	2.20	2.30	2.39	<b>A2</b>	0.90	1.00	1.14
<b>b</b>	0.63	0.76	0.85	<b>b2</b>	0.76	0.85	1.05
<b>b3</b>	5.10	5.40	5.60	<b>C</b>	0.46	0.51	0.61
<b>C2</b>	0.46	0.51	0.61	<b>D</b>	5.90	6.10	6.30
<b>D1</b>	5.25 REF			<b>D2</b>	0.508 BSC		
<b>E</b>	6.35	6.55	6.70	<b>E1</b>	5.06 REF		
<b>E2</b>	1.524 BSC			<b>e</b>	2.29 BSC		
<b>e1</b>	4.57 BSC			<b>L</b>	3.70	4.00	4.40
<b>L1</b>	1.15 REF			<b>L2</b>	0.90	1.06	1.20