

Features

- Advanced high cell density Trench technology
- Super Low Gate Charge
- Excellent CdV/dt effect decline
- 100% EAS Guaranteed
- Green Device Available

Applications

- High Frequency Point-of-Load, Synchronous Buck Converter
- Networking DC-DC Power System
- Load Switch, Power Tool Application

Product Summary



V_{DS}	100	V
I_D	135	A
$R_{DS(ON)}$ (at $V_{GS}=10V$)	3.9	m Ω

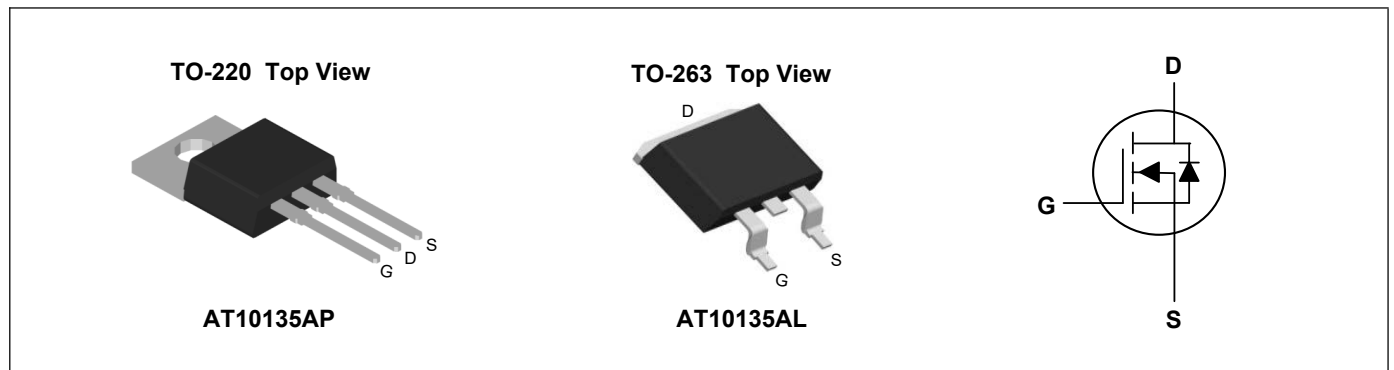

Absolute Maximum Ratings($T_C=25^\circ C$, unless otherwise noted)

Parameter	Symbol	Rating	Units
Drain-Source Voltage	V_{DS}	100	V
Gate-Source Voltage	V_{GS}	± 20	V
Continuous Drain Current	$I_D@T_C=25^\circ C$	135	A
Continuous Drain Current	$I_D@T_C=100^\circ C$	108	A
Pulsed Drain Current	I_{DM}	540	A
Single Pulse Avalanche Energy ³	EAS	1156	mJ
Total Power Dissipation	$P_D@T_C=25^\circ C$	220	W
Storage Temperature Range	T_{STG}	-55 to 175	$^\circ C$
Operating Junction Temperature Range	T_J	-55 to 175	$^\circ C$

Thermal Characteristics

Parameter	Symbol	Typ	Max	Unit
Thermal Resistance Junction-Case ¹	$R_{\theta JC}$	---	0.68	$^\circ C/W$

Electrical Characteristics (T_J=25°C, unless otherwise noted)

Parameter	Symbol	Conditions	Min	Typ	Max	Unit
Drain-Source Breakdown Voltage	BV _{DSS}	V _{GS} =0V, I _D =250uA	100	---	---	V
Static Drain-Source On-Resistance	R _{DS(ON)}	V _{GS} =10V, I _D =65A TO-220	---	3.65	3.9	mΩ
		V _{GS} =10V, I _D =65A TO-263	---	3.5	3.9	mΩ
Gate Threshold Voltage	V _{GS(th)}	V _{GS} =V _{DS} , I _D =250uA	2.0	3.0	4.0	V
Drain-Source Leakage Current	I _{DSS}	V _{DS} =100V, V _{GS} =0V, T _J =25°C	---	---	1	uA
Gate-Source Leakage Current	I _{GSS}	V _{GS} =±20V, V _{DS} =0V	---	---	±100	nA
Forward Transconductance	g _{fs}	V _{DS} =5V, I _D =65A	---	90	---	S
Gate Resistance	R _g	V _{DS} =0V, V _{GS} =0V, f=1MHz	---	1.5	---	Ω
Total Gate Charge	Q _g	V _{DS} =50V, V _{GS} =10V, I _D =65A	---	102	---	nC
Gate-Source Charge	Q _{gs}		---	36	---	
Gate-Drain Charge	Q _{gd}		---	26	---	
Turn-On Delay Time	T _{d(on)}	V _{DD} =50V, I _D =65A, V _{GS} =10V, R _G =1.6Ω	---	20	---	ns
Rise Time	T _r		---	11.5	---	
Turn-Off Delay Time	T _{d(off)}		---	48	---	
Fall Time	T _f		---	10	---	
Input Capacitance	C _{iss}	V _{DS} =50V, V _{GS} =0V, f=1MHz	---	6400	---	pF
Output Capacitance	C _{oss}		---	585	---	
Reverse Transfer Capacitance	C _{rss}		---	26	---	

Drain-Source Diode Characteristics

Parameter	Symbol	Conditions	Min	Typ	Max	Unit
Continuous Source Current ¹	I _S		---	---	135	A
Diode Forward Voltage ²	V _{SD}	V _{GS} =0V, I _S =65A, T _J =25°C	---	---	1.2	V
Reverse Recovery Time	t _{rr}	I _F =65A, di/dt=100A/μs, T _J =25°C	---	76	---	nS
Reverse Recovery Charge	Q _{rr}		---	150	---	nC

Note:

- The data tested by surface mounted on a 1 inch² FR-4 board with 2OZ copper.
- The data tested by pulsed, pulse width ≤ 300us, duty cycle ≤ 2%
- The EAS data shows Max. rating. The test condition is V_{DD}=50V, V_{GS}=10V, L=0.5mH, R_G=25Ω

Typical Characteristics

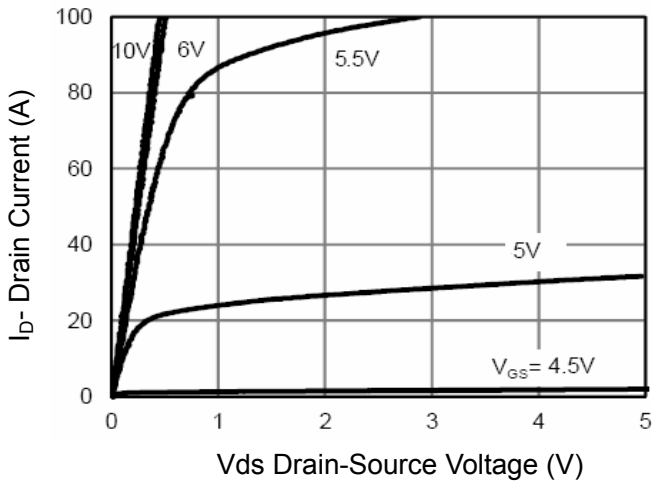

Figure 1 Output Characteristics

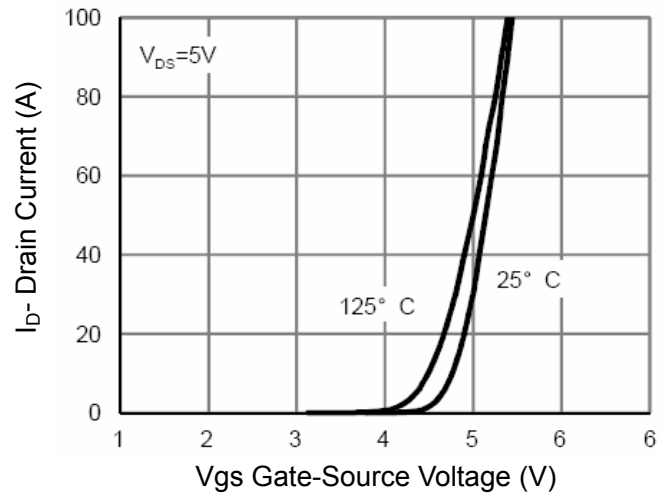

Figure 2 Transfer Characteristics

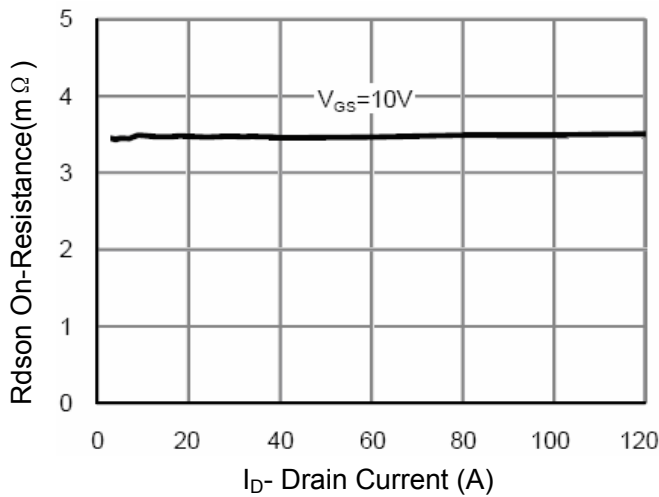

Figure 3 Rdson- Drain Current

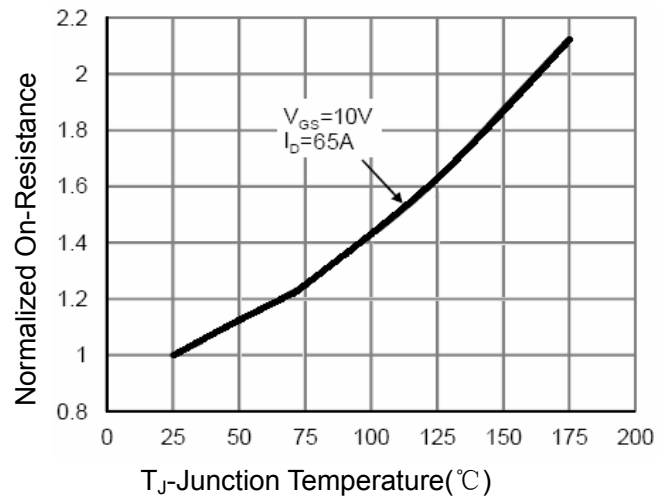

Figure 4 Rdson-Junction Temperature

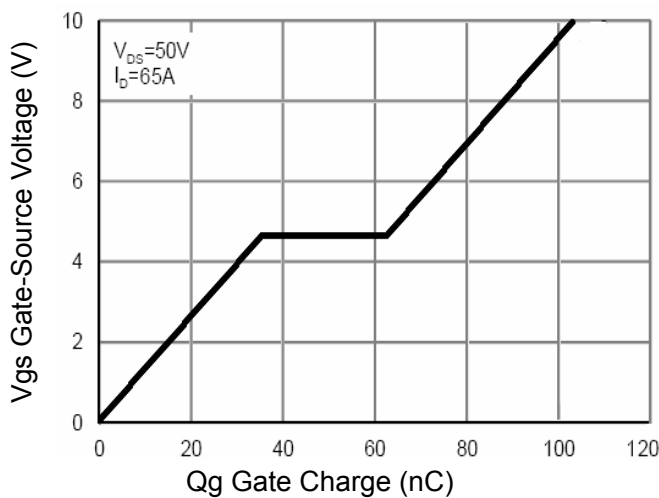

Figure 5 Gate Charge

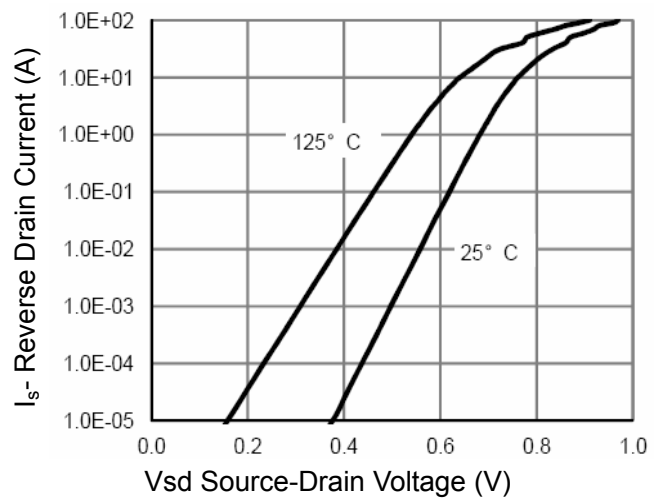

Figure 6 Source- Drain Diode Forward

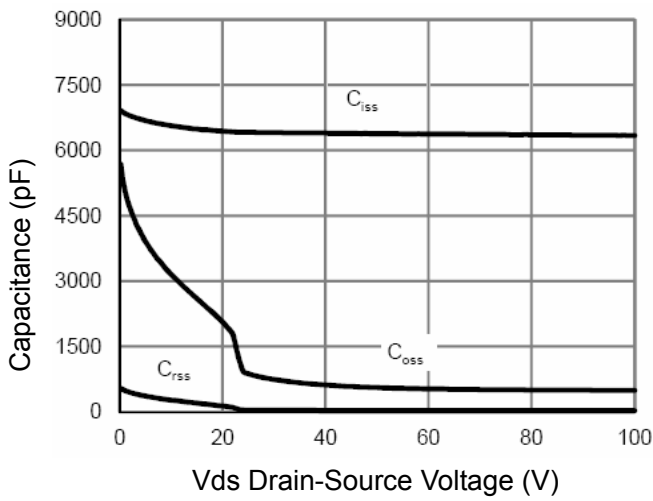

Figure 7 Capacitance vs Vds

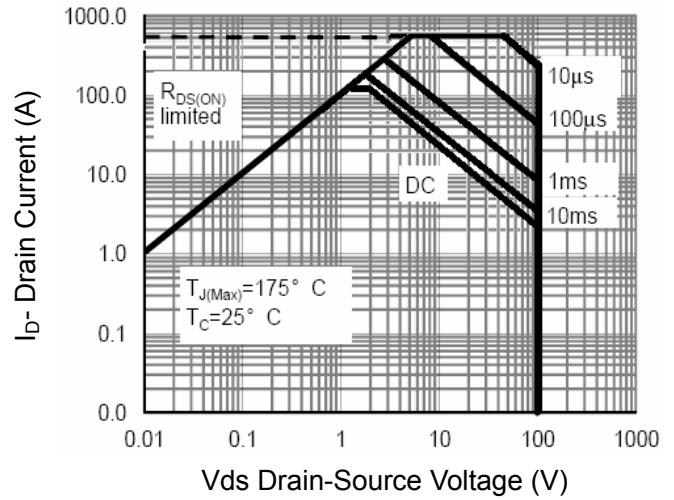

Figure 8 Safe Operation Area

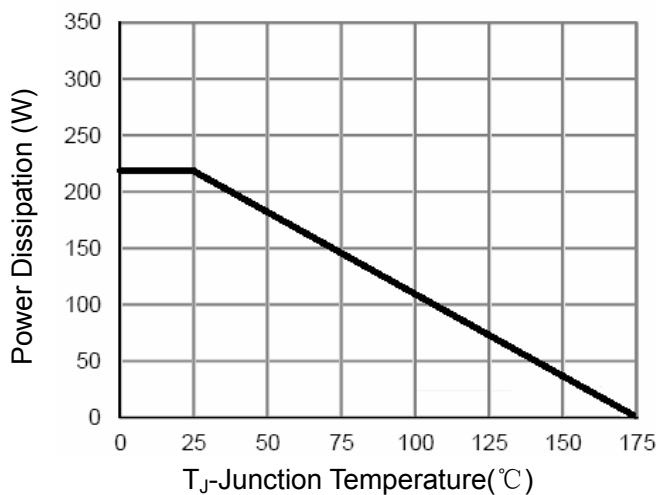

Figure 9 Power De-rating

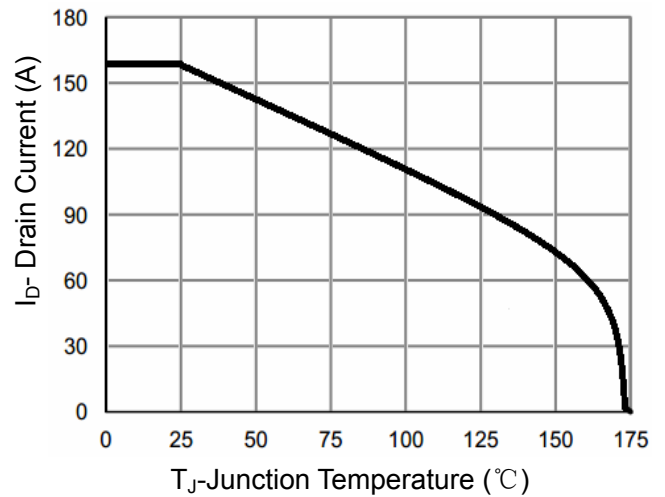

Figure 10 Current De-rating

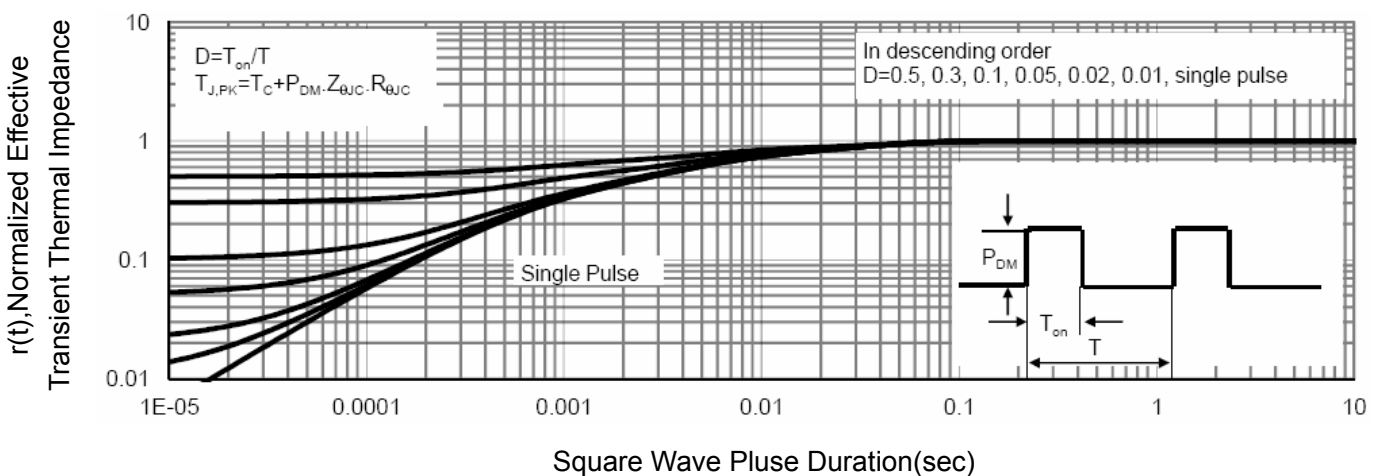
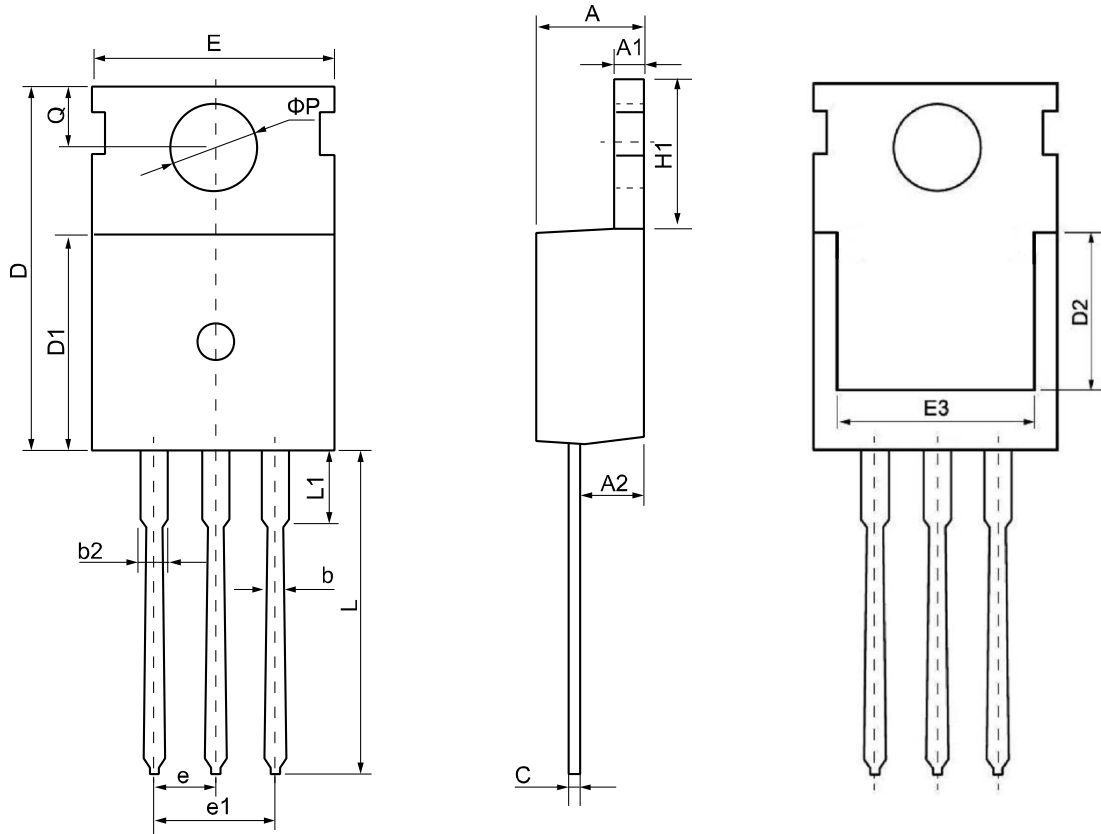

Figure 11 Normalized Maximum Transient Thermal Impedance

TO-220 Package Outline Dimensions



Symbol	Dimensions (unit:mm)			Symbol	Dimensions (unit:mm)		
	Min	Typ	Max		Min	Typ	Max
A	4.30	4.55	4.75	E	9.65	10.00	10.25
A1	1.15	1.30	1.45	E3	7.00	--	--
A2	2.20	2.40	2.60	e	2.54 BSC		
b	0.70	0.80	0.95	e1	5.08 BSC		
b2	1.17	1.27	1.47	H1	6.30	6.50	6.80
c	0.40	0.50	0.65	L	12.70	13.50	14.10
D	15.30	15.60	15.90	L1	--	3.20	3.95
D1	8.90	9.10	9.35	phi P	3.40	3.60	3.80
D2	5.50	--	--	Q	2.60	2.80	3.00

TO-263 Package Outline Dimensions

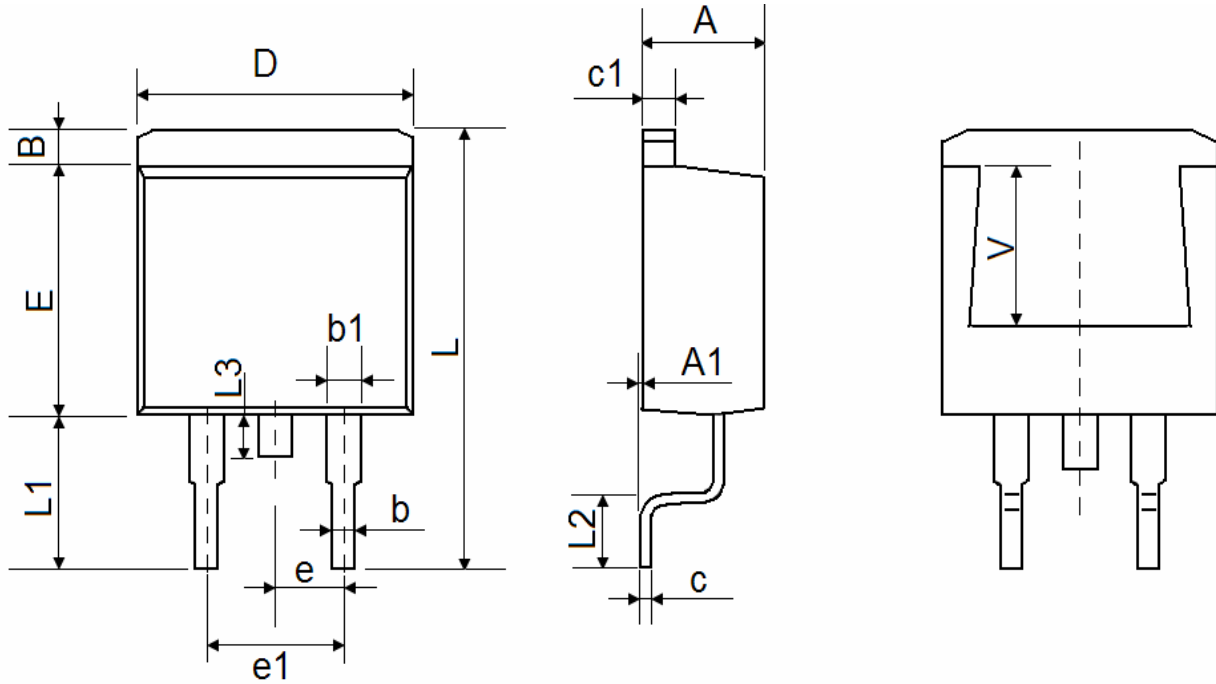

Symbol	Dimensions (unit:mm)			Symbol	Dimensions (unit:mm)		
	Min	Typ	Max		Min	Typ	Max
A	4.40	4.55	4.70	A1	0.00	0.07	0.15
B	1.00	1.20	1.40	b	0.65	0.80	0.95
b1	1.10	1.15	1.37	c	0.30	0.40	0.53
c1	1.10	1.25	1.37	D	9.80	10.00	10.40
E	8.50	8.80	9.20	e	2.54 REF		
e1	4.90	5.10	5.40	L	14.80	15.20	15.70
L1	5.00	5.25	5.60	L2	2.05	2.45	2.80
L3	1.20	1.50	1.80	V	5.60 REF		