

**Features**

- Advanced high cell density Trench technology
- Super Low Gate Charge
- Excellent CdV/dt effect decline
- Green Device Available

**Product Summary**



$V_{DS}$	100	V
$I_D$	10	A
$R_{DS(ON)}$ (at $V_{GS}=10V$ )	130	m $\Omega$
$R_{DS(ON)}$ (at $V_{GS}=4.5V$ )	140	m $\Omega$

**Applications**

- High Frequency Point-of-Load, Synchronous Buck Converter
- Networking DC-DC Power System
- Load Switch

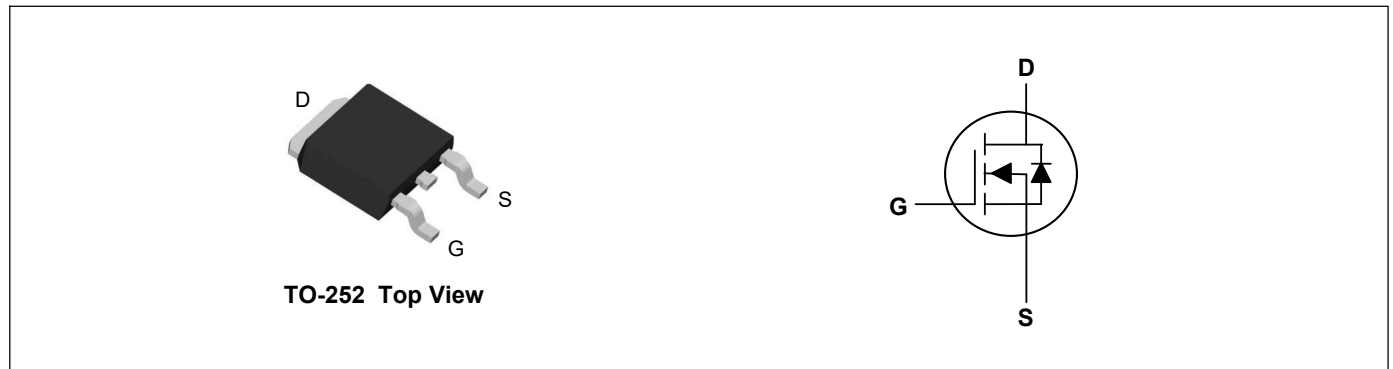

**Absolute Maximum Ratings( $T_C=25^{\circ}C$ , unless otherwise noted)**

Parameter	Symbol	Rating	Units
Drain-Source Voltage	$V_{DS}$	100	V
Gate-Source Voltage	$V_{GS}$	$\pm 20$	V
Continuous Drain Current <sup>1</sup>	$I_D$	10	A
Continuous Drain Current <sup>1</sup>	$I_D@T_C=100^{\circ}C$	7	A
Pulsed Drain Current <sup>2</sup>	$I_{DM}$	40	A
Single Pulse Avalanche Energy <sup>3</sup>	EAS	20	mJ
Total Power Dissipation <sup>4</sup>	$P_D$	40	W
Storage Temperature Range	$T_{STG}$	-55 to 175	$^{\circ}C$
Operating Junction Temperature Range	$T_J$	-55 to 175	$^{\circ}C$

**Thermal Characteristics**

Parameter	Symbol	Typ	Max	Unit
Thermal Resistance Junction-Case <sup>1</sup>	$R_{\theta JC}$	---	3.8	$^{\circ}C/W$

**Electrical Characteristics (T<sub>J</sub>=25°C, unless otherwise noted)**

Parameter	Symbol	Conditions	Min	Typ	Max	Unit
Drain-Source Breakdown Voltage	BV <sub>DSS</sub>	V <sub>GS</sub> =0V, I <sub>D</sub> =250uA	100	110	---	V
Static Drain-Source On-Resistance	R <sub>DS(ON)</sub>	V <sub>GS</sub> =10V, I <sub>D</sub> =10A	---	95	130	mΩ
		V <sub>GS</sub> =4.5V, I <sub>D</sub> =8A	---	100	140	mΩ
Gate Threshold Voltage	V <sub>GS(th)</sub>	V <sub>GS</sub> =V <sub>DS</sub> , I <sub>D</sub> =250uA	1	1.5	2	V
Drain-Source Leakage Current	I <sub>DSS</sub>	V <sub>DS</sub> =100V, V <sub>GS</sub> =0V, T <sub>J</sub> =25°C	---	---	1	uA
Gate-Source Leakage Current	I <sub>GSS</sub>	V <sub>GS</sub> =±20V, V <sub>DS</sub> =0V	---	---	±100	nA
Forward Transconductance	g <sub>fs</sub>	V <sub>DS</sub> =25V, I <sub>D</sub> =6A	3.5	---	---	S
Total Gate Charge	Q <sub>g</sub>	V <sub>DS</sub> =50V, V <sub>GS</sub> =10V, I <sub>D</sub> =10A	---	21.5	---	nC
Gate-Source Charge	Q <sub>gs</sub>		---	3.2	---	
Gate-Drain Charge	Q <sub>gd</sub>		---	6	---	
Turn-On Delay Time	T <sub>d(on)</sub>	V <sub>DD</sub> =50V, R <sub>G</sub> =2.5Ω, V <sub>GS</sub> =10V, R <sub>L</sub> =15Ω	---	11	---	ns
Rise Time	T <sub>r</sub>		---	7.4	---	
Turn-Off Delay Time	T <sub>d(off)</sub>		---	35	---	
Fall Time	T <sub>f</sub>		---	9.1	---	
Input Capacitance	C <sub>iss</sub>	V <sub>DS</sub> =50V, V <sub>GS</sub> =0V, f=1MHz	---	980	---	pF
Output Capacitance	C <sub>oss</sub>		---	37	---	
Reverse Transfer Capacitance	C <sub>rss</sub>		---	27	---	

**Drain-Source Diode Characteristics**

Parameter	Symbol	Conditions	Min	Typ	Max	Unit
Continuous Source Current <sup>2</sup>	I <sub>S</sub>		---	---	10	A
Diode Forward Voltage <sup>1</sup>	V <sub>SD</sub>	V <sub>GS</sub> =0V, I <sub>F</sub> =10A, T <sub>J</sub> =25°C	---	---	1.2	V
Reverse Recovery Time	t <sub>rr</sub>	I <sub>F</sub> =10A, di/dt=100A/μs, T <sub>J</sub> =25°C	---	21	---	nS
Reverse Recovery Charge	Q <sub>rr</sub>		---	97	---	nC

**Note:**

1. The data tested by surface mounted on a 1 inch<sup>2</sup> FR-4 board with 2OZ copper.
2. The data tested by pulsed, pulse width ≤ 300us, duty cycle ≤ 2%
3. The EAS data shows Max. rating. The test condition is V<sub>DD</sub>=50V, V<sub>GS</sub>=10V, L=0.5mH
4. The power dissipation is limited by 175°C junction temperature

**Typical Characteristics**

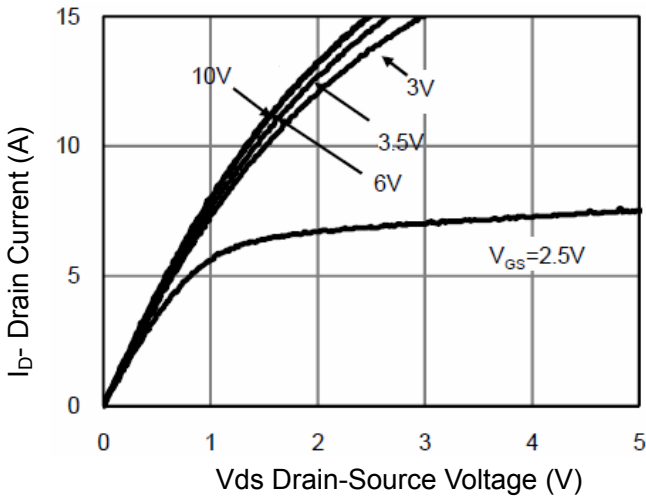

**Figure 1 Output Characteristics**

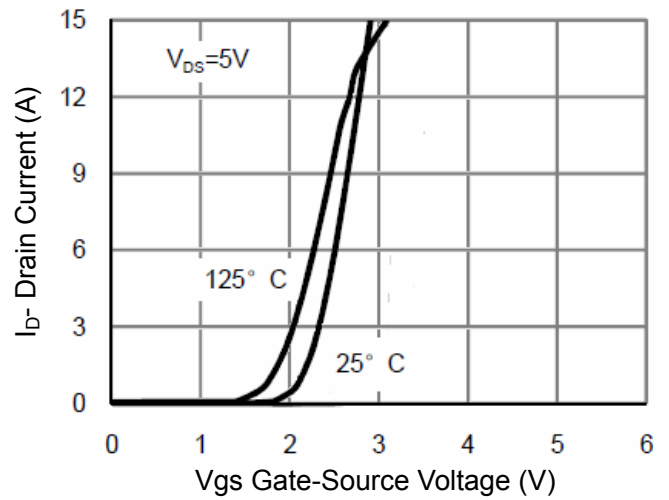

**Figure 2 Transfer Characteristics**

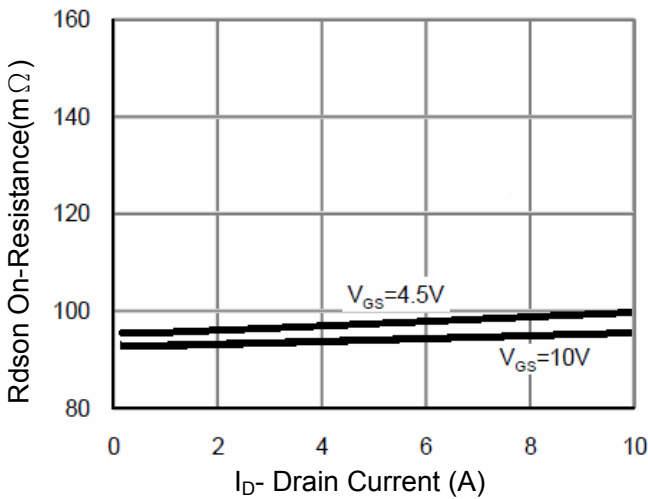

**Figure 3 Rdson- Drain Current**

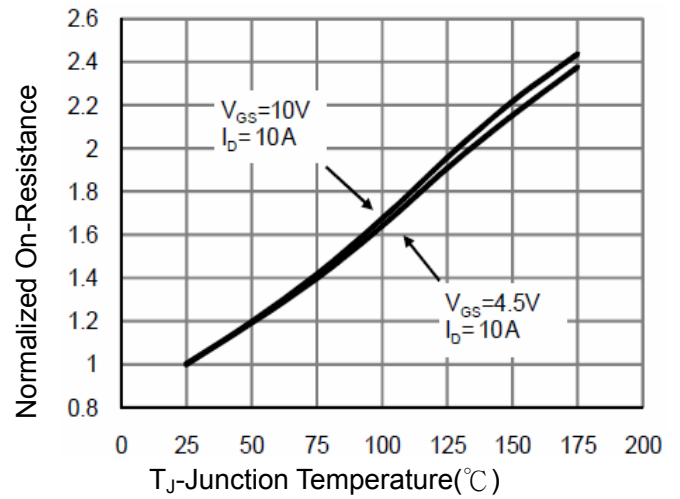

**Figure 4 Rdson-Junction Temperature**

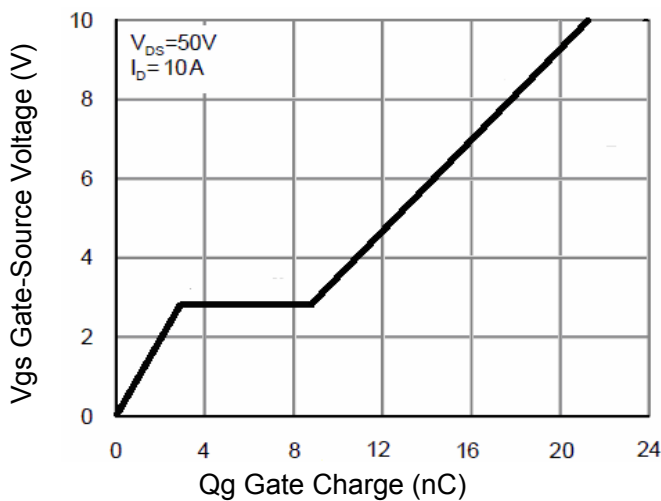

**Figure 5 Gate Charge**

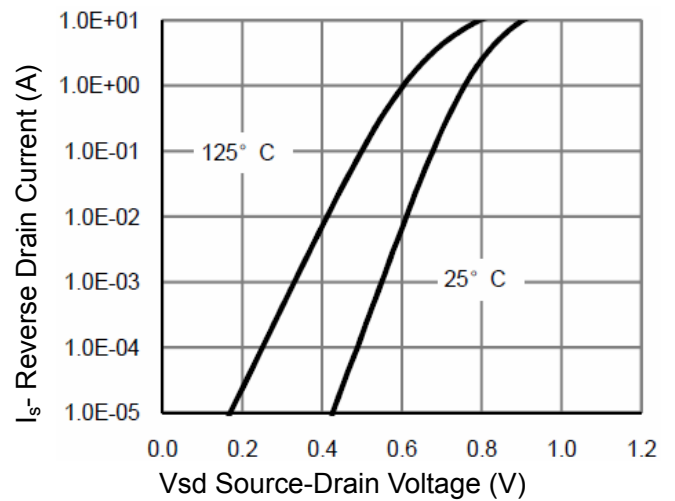

**Figure 6 Source- Drain Diode Forward**

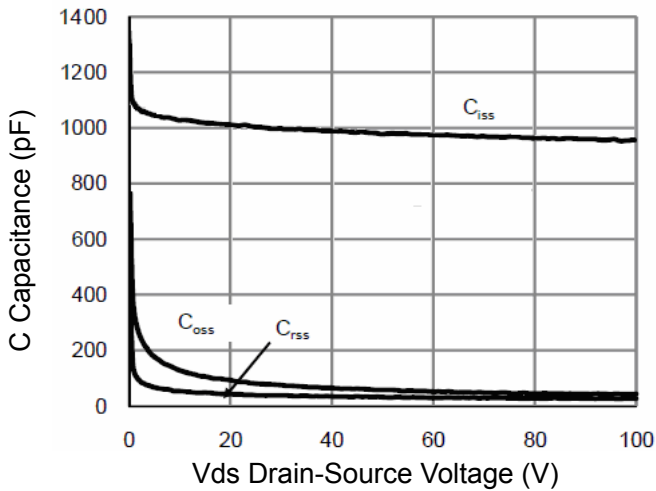

Figure 7 Capacitance vs Vds

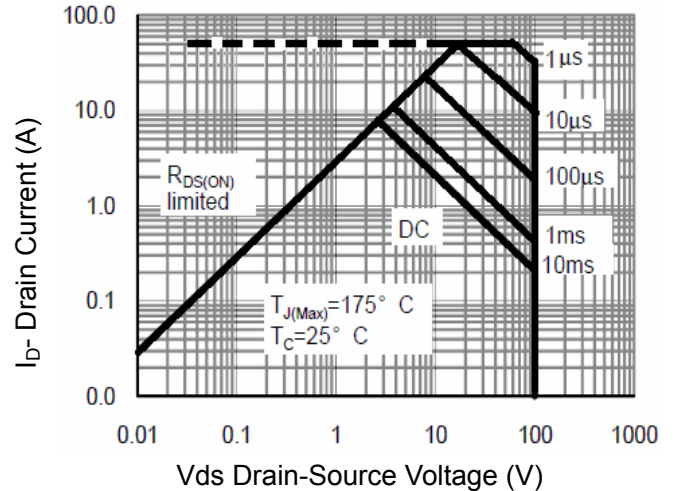

Figure 8 Safe Operation Area

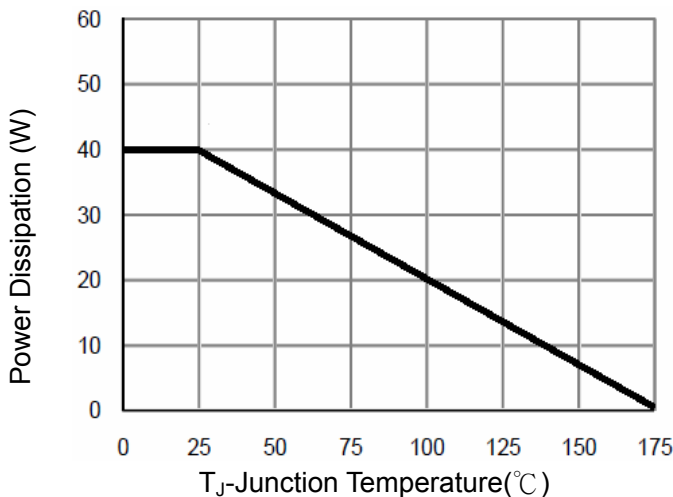

Figure 9 Power De-rating

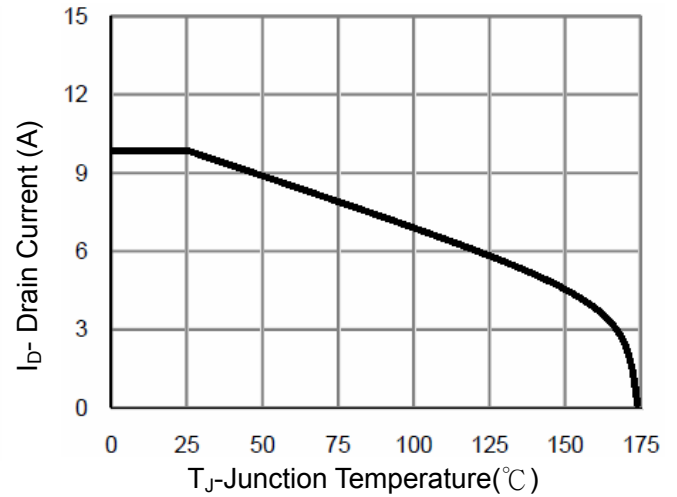

Figure 10 Current De-rating

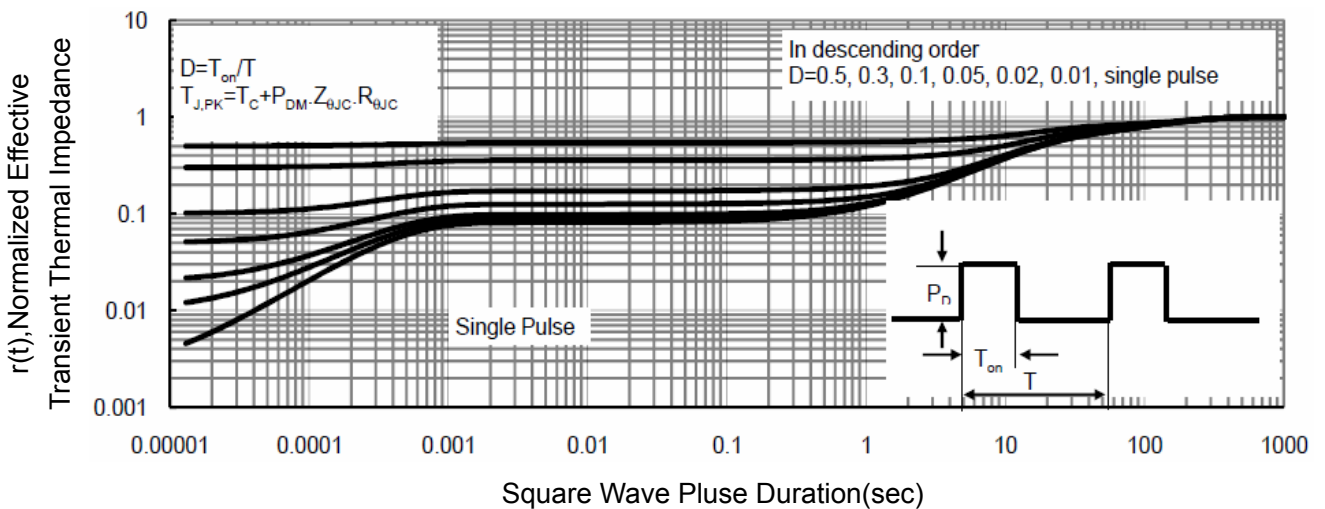
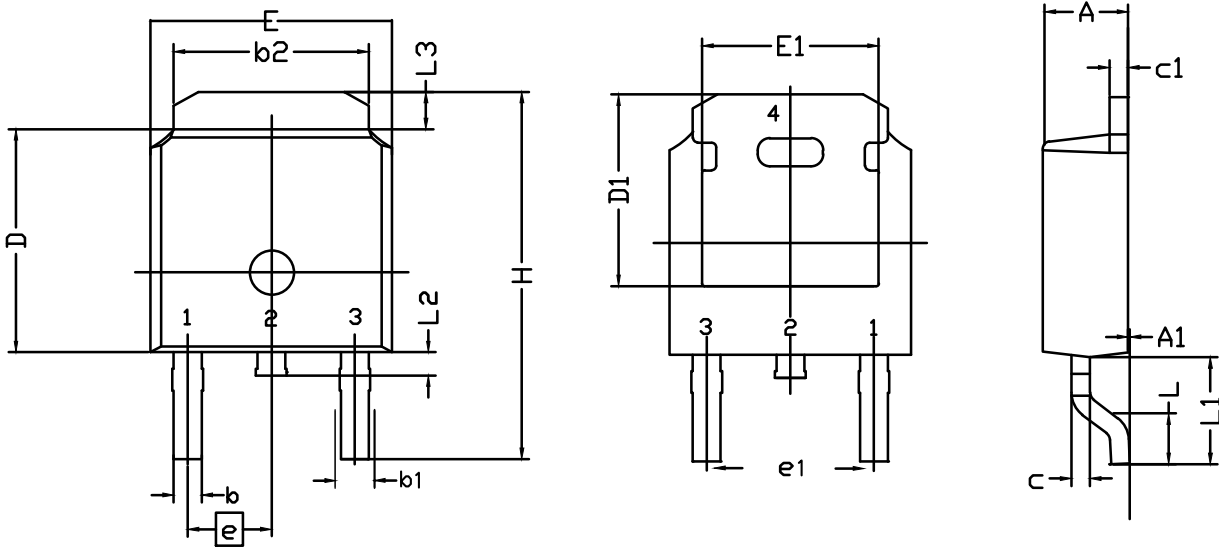

Figure 11 Normalized Maximum Transient Thermal Impedance

**TO-252 Package Outline Dimensions**



Symbol	Dimensions (unit:mm)			Symbol	Dimensions (unit:mm)		
	Min	Typ	Max		Min	Typ	Max
<b>A</b>	2.20	2.30	2.38	<b>E</b>	6.40	6.60	6.731
<b>A<sub>1</sub></b>	0.00	0.10	0.20	<b>E<sub>1</sub></b>	4.40	--	--
<b>b</b>	0.64	0.76	0.89	<b>e</b>	2.286 BSC		
<b>b<sub>1</sub></b>	0.77	0.85	1.14	<b>e<sub>1</sub></b>	4.572 BSC		
<b>b<sub>2</sub></b>	5.00	5.33	5.46	<b>H</b>	9.40	10.00	10.40
<b>c</b>	0.458	0.508	0.610	<b>L</b>	1.40	1.52	1.77
<b>C<sub>1</sub></b>	0.458	0.508	0.620	<b>L<sub>1</sub></b>	--	2.743	--
<b>D</b>	5.98	6.10	6.223	<b>L<sub>2</sub></b>	0.60	0.80	1.01
<b>D<sub>1</sub></b>	5.20	5.25	5.38	<b>L<sub>3</sub></b>	0.90	1.06	1.25