



## Features

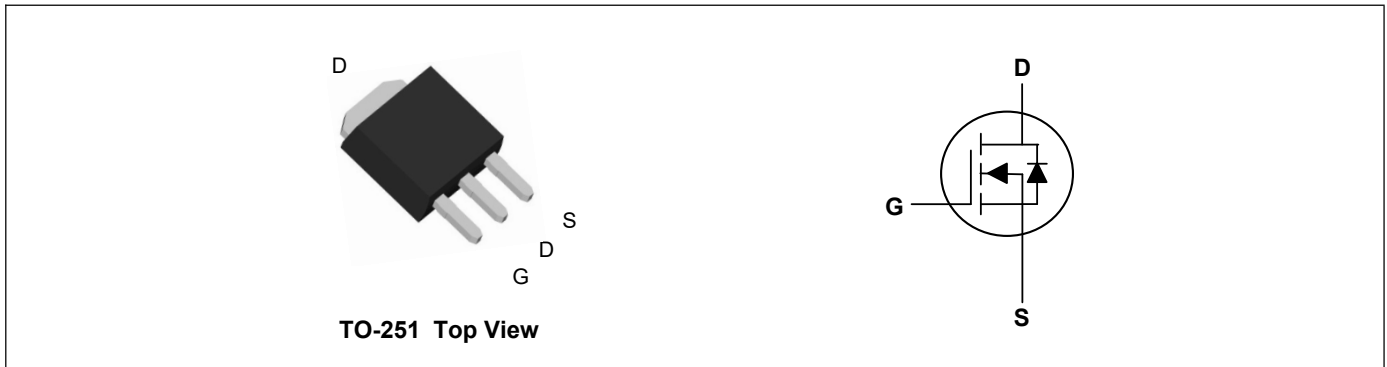
- Advanced high cell density Trench technology
- Super Low Gate Charge
- Excellent CdV/dt effect decline
- 100% EAS Guaranteed
- Green Device Available

## Product Summary

$V_{DS}$	80	V
$I_D$	11.8	A
$R_{DS(ON)}$ (at $V_{GS}=10V$ )	100	m $\Omega$
$R_{DS(ON)}$ (at $V_{GS}=4.5V$ )	115	m $\Omega$

## Applications

- High Frequency Point-of-Load, Synchronous Buck Converter for
- Networking DC-DC Power System
- Load Switch



## Absolute Maximum Ratings ( $T_A=25^\circ\text{C}$ , unless otherwise noted)

Parameter	Symbol	Rating	Units
Drain-Source Voltage	$V_{DS}$	80	V
Gate-Source Voltage	$V_{GS}$	$\pm 20$	V
Continuous Drain Current, $V_{GS} @ 10V^1$	$I_D @ T_C=25^\circ\text{C}$	11.8	A
Continuous Drain Current, $V_{GS} @ 10V^1$	$I_D @ T_C=100^\circ\text{C}$	7.5	A
Continuous Drain Current, $V_{GS} @ 10V^1$	$I_D @ T_A=25^\circ\text{C}$	3	A
Continuous Drain Current, $V_{GS} @ 10V^1$	$I_D @ T_A=70^\circ\text{C}$	2.4	A
Pulsed Drain Current <sup>2</sup>	$I_{DM}$	25	A
Single Pulse Avalanche Energy <sup>3</sup>	EAS	14.5	mJ
Avalanche Current	$I_{AS}$	17	A
Total Power Dissipation <sup>4</sup>	$P_D @ T_C=25^\circ\text{C}$	31.3	W
Total Power Dissipation <sup>4</sup>	$P_D @ T_A=25^\circ\text{C}$	2	W
Storage Temperature Range	$T_{STG}$	-55 to 150	$^\circ\text{C}$
Operating Junction Temperature Range	$T_J$	-55 to 150	$^\circ\text{C}$

## Thermal Characteristics

Parameter	Symbol	Typ	Max	Unit
Thermal Resistance Junction-Ambient <sup>1</sup>	$R_{\theta JA}$	---	62	$^\circ\text{C/W}$
Thermal Resistance Junction-Case <sup>1</sup>	$R_{\theta JC}$	---	4	$^\circ\text{C/W}$

**Electrical Characteristics (T<sub>J</sub>=25°C, unless otherwise noted)**

Parameter	Symbol	Conditions	Min	Typ	Max	Unit
Drain-Source Breakdown Voltage	BV <sub>DSS</sub>	V <sub>GS</sub> =0V, I <sub>D</sub> =250uA	80	---	---	V
BV <sub>DSS</sub> Temperature Coefficient	ΔBV <sub>DSS</sub> /ΔT <sub>J</sub>	Reference to 25°C, I <sub>D</sub> =1mA	---	0.072	---	V/°C
Static Drain-Source On-Resistance <sup>2</sup>	R <sub>DS(ON)</sub>	V <sub>GS</sub> =10V, I <sub>D</sub> =10A	---	---	100	mΩ
		V <sub>GS</sub> =4.5V, I <sub>D</sub> =8A	---	---	115	mΩ
Gate Threshold Voltage	V <sub>GS(th)</sub>	V <sub>GS</sub> =V <sub>DS</sub> , I <sub>D</sub> =250uA	1.2	---	2.5	V
V <sub>GS(th)</sub> Temperature Coefficient	ΔV <sub>GS(th)</sub>		---	-4.7	---	mV/°C
Drain-Source Leakage Current	I <sub>DSS</sub>	V <sub>DS</sub> =64V, V <sub>GS</sub> =0V, T <sub>J</sub> =25°C	---	---	1	uA
		V <sub>DS</sub> =64V, V <sub>GS</sub> =0V, T <sub>J</sub> =55°C	---	---	5	
Gate-Source Leakage Current	I <sub>GSS</sub>	V <sub>GS</sub> =±20V, V <sub>DS</sub> =0V	---	---	±100	nA
Forward Transconductance	g <sub>fs</sub>	V <sub>DS</sub> =5V, I <sub>D</sub> =10A	---	14.7	---	S
Gate Resistance	R <sub>g</sub>	V <sub>DS</sub> =0V, V <sub>GS</sub> =0V, f=1MHz	---	2.8	---	Ω
Total Gate Charge	Q <sub>g</sub>	V <sub>DS</sub> =64V, V <sub>GS</sub> =10V, I <sub>D</sub> =10A	---	18.6	---	nC
Gate-Source Charge	Q <sub>gs</sub>		---	3.9	---	
Gate-Drain Charge	Q <sub>gd</sub>		---	3.2	---	
Turn-On Delay Time	T <sub>d(on)</sub>	V <sub>DD</sub> =40V, V <sub>GS</sub> =10V, R <sub>G</sub> =3.3Ω, I <sub>D</sub> =10A	---	5	---	ns
Rise Time	T <sub>r</sub>		---	25	---	
Turn-Off Delay Time	T <sub>d(off)</sub>		---	21	---	
Fall Time	T <sub>f</sub>		---	7.6	---	
Input Capacitance	C <sub>iss</sub>	V <sub>DS</sub> =15V, V <sub>GS</sub> =0V, f=1MHz	---	1090	---	pF
Output Capacitance	C <sub>oss</sub>		---	60	---	
Reverse Transfer Capacitance	C <sub>rss</sub>		---	41	---	

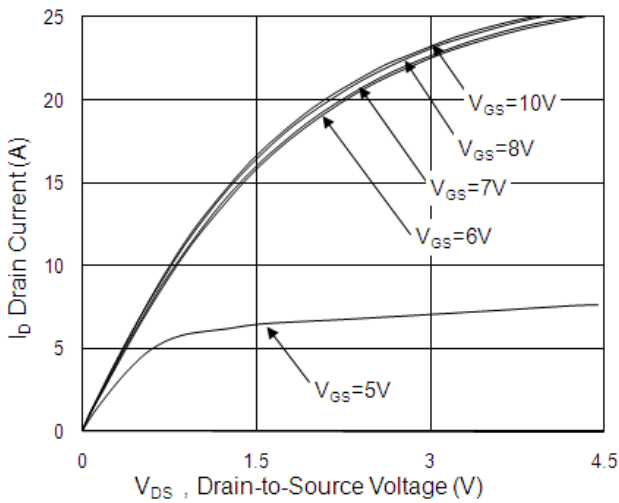
**Drain-Source Diode Characteristics**

Parameter	Symbol	Conditions	Min	Typ	Max	Unit
Continuous Source Current <sup>1,5</sup>	I <sub>S</sub>	V <sub>G</sub> =V <sub>D</sub> =0V, Force Current	---	---	11.8	A
Pulsed Source Current <sup>2,5</sup>	I <sub>SM</sub>		---	---	25	A
Diode Forward Voltage <sup>2</sup>	V <sub>SD</sub>	V <sub>GS</sub> =0V, I <sub>S</sub> =1A, T <sub>J</sub> =25°C	---	---	1.2	V
Reverse Recovery Time	t <sub>rr</sub>	I <sub>F</sub> =15A, di/dt=100A/μs, T <sub>J</sub> =25°C	---	18.6	---	nS
Reverse Recovery Charge	Q <sub>rr</sub>		---	17.7	---	nC

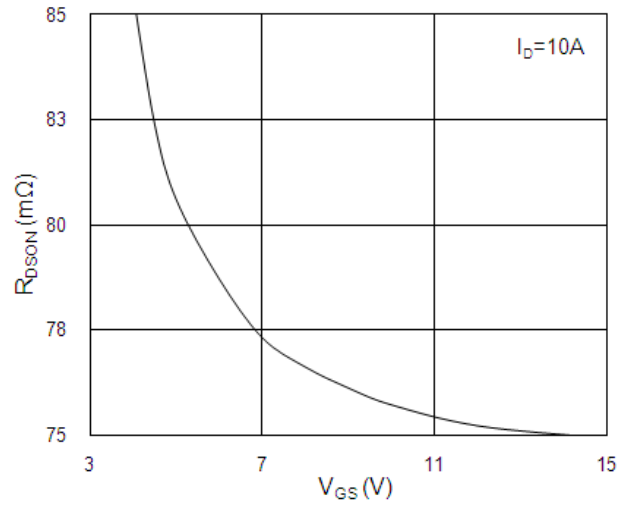
**Note:**

1. The data tested by surface mounted on a 1 inch<sup>2</sup> FR-4 board with 2OZ copper.
2. The data tested by pulsed, pulse width ≤ 300us, duty cycle ≤ 2%
3. The EAS data shows Max. rating. The test condition is V<sub>DD</sub>=50V, V<sub>GS</sub>=10V, L=0.1mH
4. The power dissipation is limited by 150°C junction temperature
5. The data is theoretically the same as I<sub>D</sub> and I<sub>DM</sub>, in real applications, should be limited by total power dissipation.

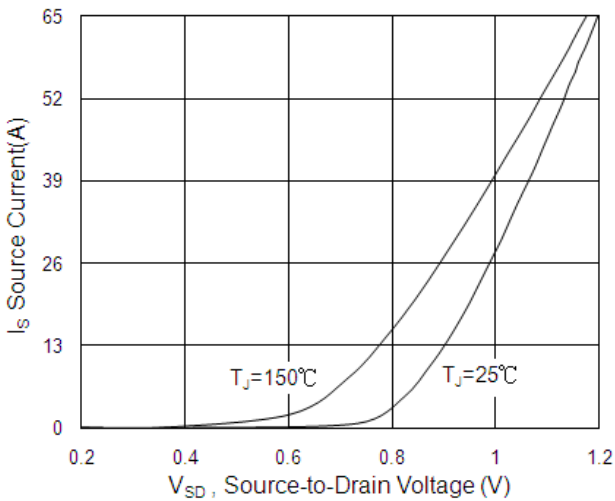
**Typical Characteristics**



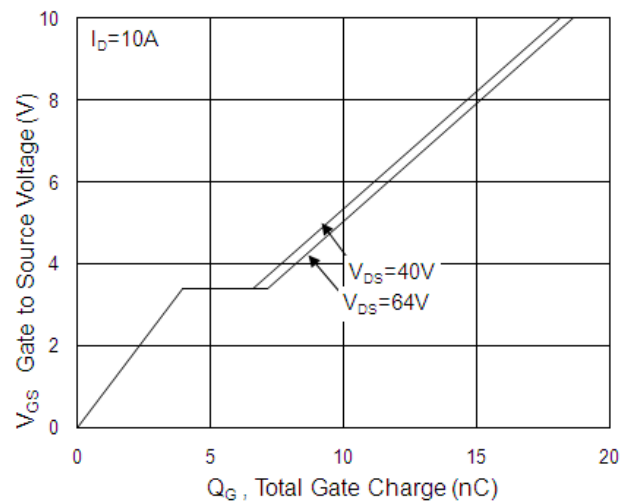
**Fig.1 Typical Output Characteristics**



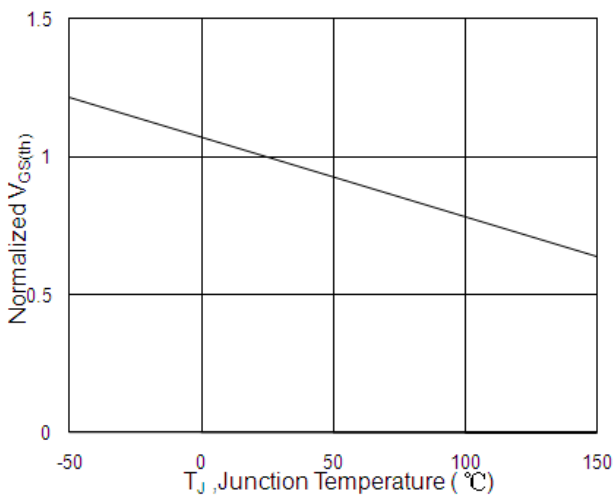
**Fig.2 On-Resistance v.s Gate-Source**



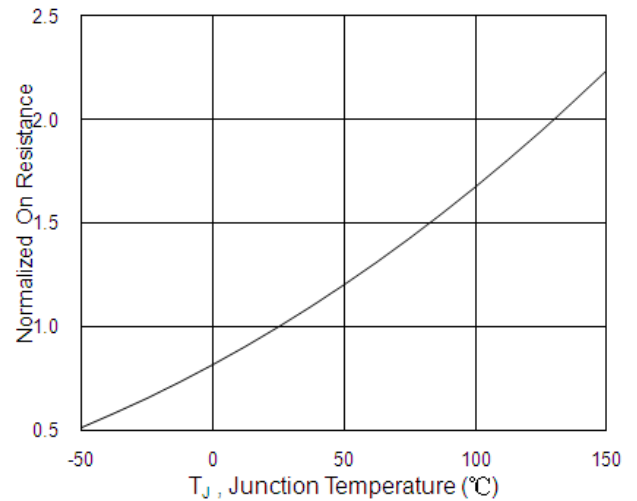
**Fig.3 Forward Characteristics of Reverse**



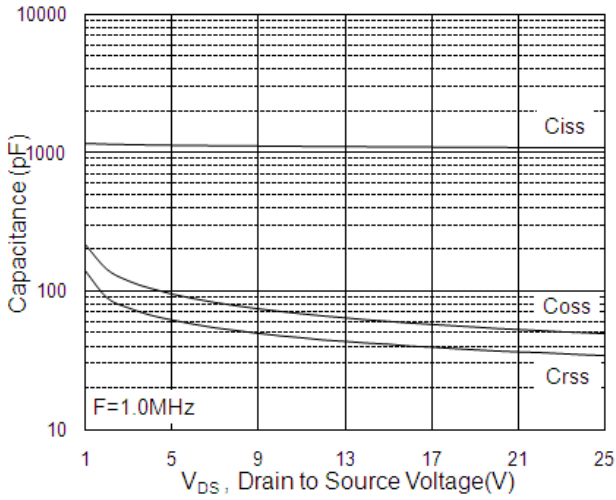
**Fig.4 Gate-Charge Characteristics**



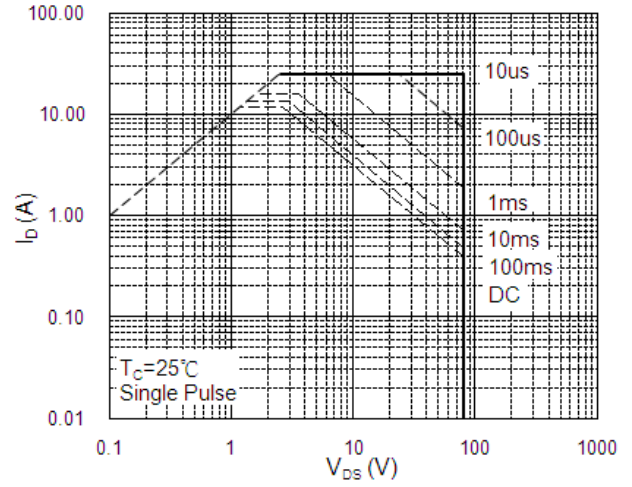
**Fig.5 Normalized V<sub>GS(th)</sub> vs. T<sub>J</sub>**



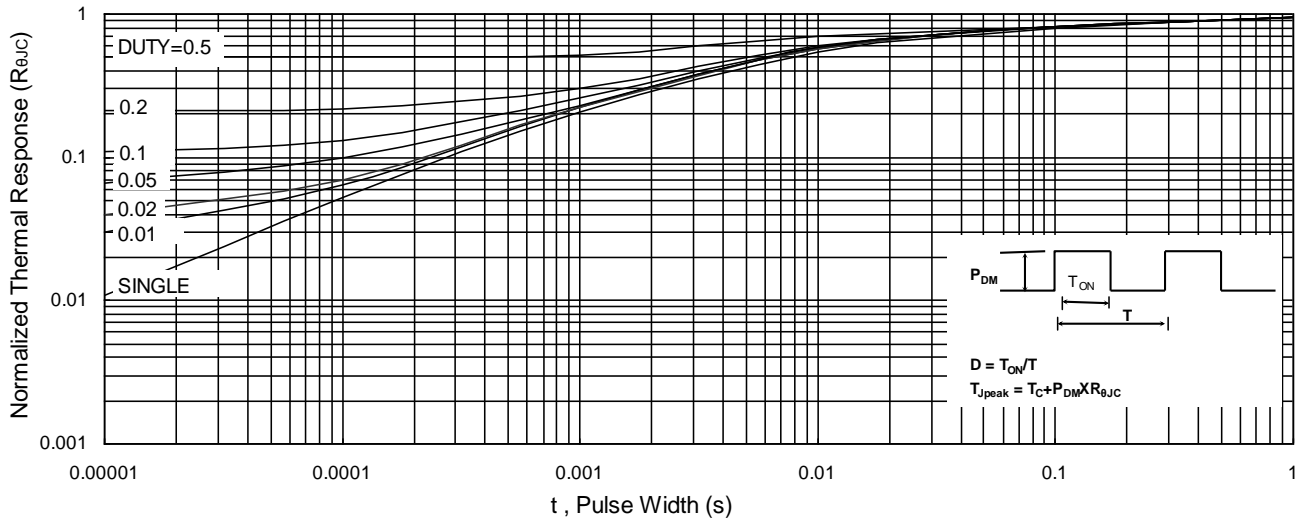
**Fig.6 Normalized R<sub>DS(ON)</sub> vs. T<sub>J</sub>**



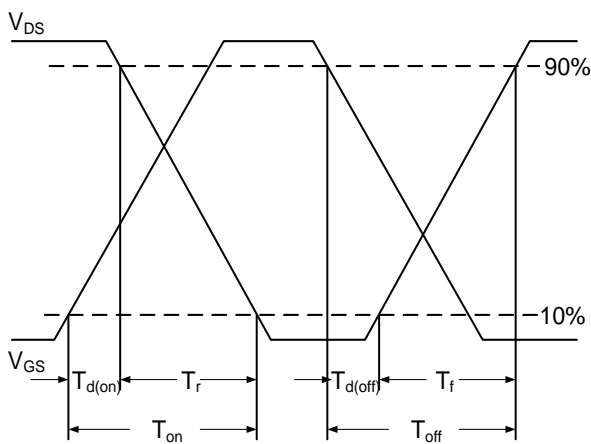
**Fig.7 Capacitance**



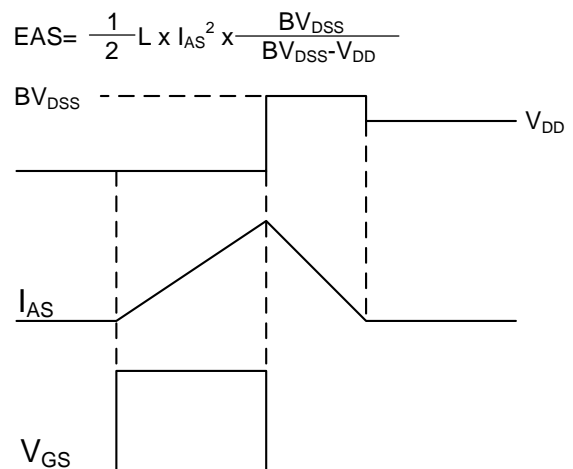
**Fig.8 Safe Operating Area**



**Fig.9 Normalized Maximum Transient Thermal Impedance**

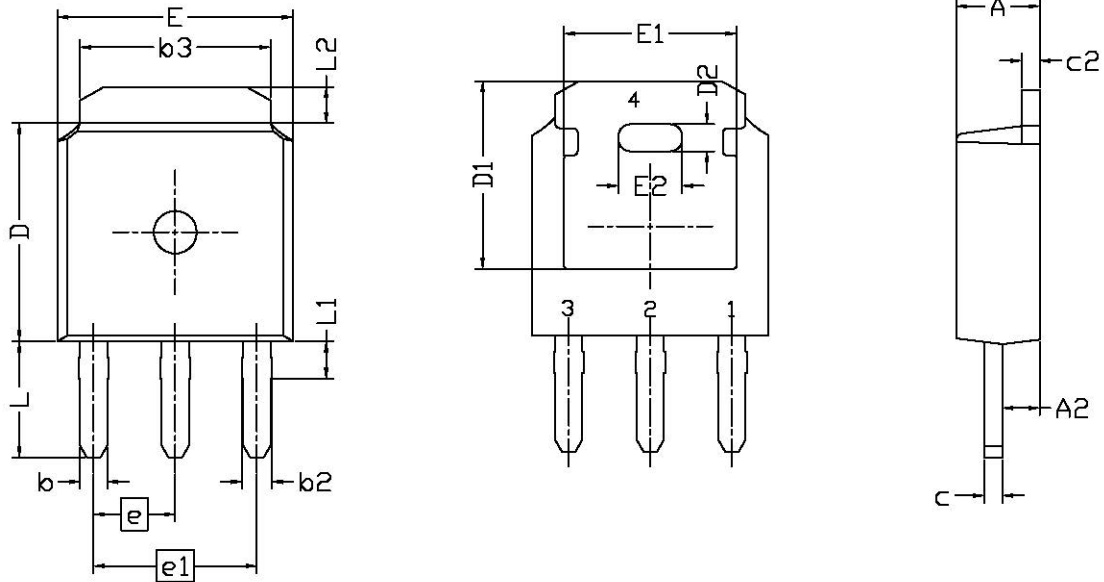


**Fig.10 Switching Time Waveform**



**Fig.11 Unclamped Inductive Switching Waveform**

**TO-251 Package Outline Dimensions**



Symbol	Dimensions (unit:mm)			Symbol	Dimensions (unit:mm)		
	Min	Typ	Max		Min	Typ	Max
<b>A</b>	2.20	2.30	2.39	<b>A2</b>	0.90	1.00	1.14
<b>b</b>	0.63	0.76	0.85	<b>b2</b>	0.76	0.85	1.05
<b>b3</b>	5.10	5.40	5.60	<b>C</b>	0.46	0.51	0.61
<b>C2</b>	0.46	0.51	0.61	<b>D</b>	5.90	6.10	6.30
<b>D1</b>	5.25 REF			<b>D2</b>	0.508 BSC		
<b>E</b>	6.35	6.55	6.70	<b>E1</b>	5.06 REF		
<b>E2</b>	1.524 BSC			<b>e</b>	2.29 BSC		
<b>e1</b>	4.57 BSC			<b>L</b>	3.70	4.00	4.40
<b>L1</b>	1.15 REF			<b>L2</b>	0.90	1.06	1.20