



Features

- Advanced high cell density Trench technology
- Super Low Gate Charge
- Excellent CdV/dt effect decline
- 100% EAS Guaranteed
- Green Device Available

Product Summary

V_{DS}	30	V
I_D	30	A
$R_{DS(ON)}$ (at $V_{GS}=10V$)	6.3	m Ω
$R_{DS(ON)}$ (at $V_{GS}=4.5V$)	9	m Ω

Applications

- High Frequency Point-of-Load, Synchronous Buck Converter
- Networking DC-DC Power System
- Load Switch

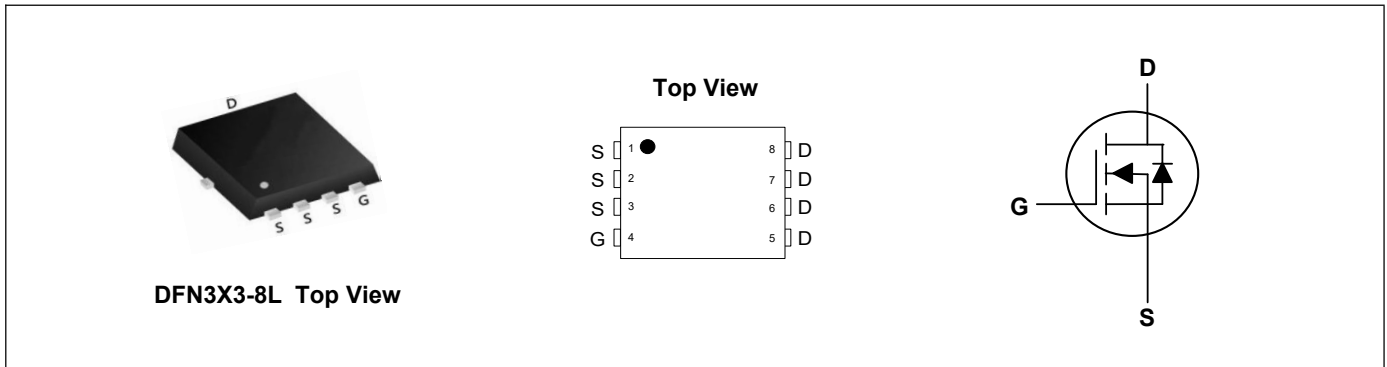

Absolute Maximum Ratings ($T_C=25^\circ\text{C}$, unless otherwise noted)

Parameter	Symbol	Rating	Units
Drain-Source Voltage	V_{DS}	30	V
Gate-Source Voltage	V_{GS}	± 20	V
Continuous Drain Current ¹	$I_D@T_C=25^\circ\text{C}$	30	A
Continuous Drain Current ¹	$I_D@T_C=100^\circ\text{C}$	24	A
Continuous Drain Current ¹	$I_D@T_A=25^\circ\text{C}$	20	A
Continuous Drain Current ¹	$I_D@T_A=70^\circ\text{C}$	15	A
Pulsed Drain Current ²	I_{DM}	100	A
Single Pulse Avalanche Energy ³	EAS	28.8	mJ
Avalanche Current	I_{AS}	24	A
Total Power Dissipation ⁴	$P_D@T_C=25^\circ\text{C}$	24	W
Storage Temperature Range	T_{STG}	-55 to 150	$^\circ\text{C}$
Operating Junction Temperature Range	T_J	-55 to 150	$^\circ\text{C}$

Thermal Characteristics

Parameter	Symbol	Typ	Max	Unit
Thermal Resistance Junction-Ambient ¹	$R_{\theta JA}$	---	60	$^\circ\text{C/W}$
Thermal Resistance Junction-Case ¹	$R_{\theta JC}$	---	5.2	$^\circ\text{C/W}$

Electrical Characteristics (T_J=25°C, unless otherwise noted)

Parameter	Symbol	Conditions	Min	Typ	Max	Unit
Drain-Source Breakdown Voltage	BV _{DSS}	V _{GS} =0V, I _D =250uA	30	---	---	V
Static Drain-Source On-Resistance ²	R _{DS(ON)}	V _{GS} =10V, I _D =20A	---	5	6.3	mΩ
		V _{GS} =4.5V, I _D =15A	---	6.9	9	mΩ
Gate Threshold Voltage	V _{GS(th)}	V _{GS} =V _{DS} , I _D =250uA	1.2	---	2.5	V
Drain-Source Leakage Current	I _{DSS}	V _{DS} =24V, V _{GS} =0V, T _J =25°C	---	---	1	uA
		V _{DS} =24V, V _{GS} =0V, T _J =55°C	---	---	5	
Gate-Source Leakage Current	I _{GSS}	V _{GS} =±20V, V _{DS} =0V	---	---	±100	nA
Forward Transconductance	g _{fs}	V _{DS} =5V, I _D =30A	---	43	---	S
Gate Resistance	R _g	V _{DS} =0V, V _{GS} =0V, f=1MHz	---	1.7	---	Ω
Total Gate Charge	Q _g	V _{DS} =15V, V _{GS} =4.5V, I _D =15A	---	8	---	nC
Gate-Source Charge	Q _{gs}		---	2.4	---	
Gate-Drain Charge	Q _{gd}		---	3.2	---	
Turn-On Delay Time	T _{d(on)}	V _{DD} =15V, V _{GS} =10V, R _G =3.3Ω, I _D =15A	---	7.1	---	ns
Rise Time	T _r		---	40	---	
Turn-Off Delay Time	T _{d(off)}		---	15	---	
Fall Time	T _f		---	6	---	
Input Capacitance	C _{iss}	V _{DS} =15V, V _{GS} =0V, f=1MHz	---	814	---	pF
Output Capacitance	C _{oss}		---	498	---	
Reverse Transfer Capacitance	C _{rss}		---	41	---	

Drain-Source Diode Characteristics

Parameter	Symbol	Conditions	Min	Typ	Max	Unit
Continuous Source Current ^{1,5}	I _S	V _G =V _D =0V, Force Current	---	---	24	A
Diode Forward Voltage ²	V _{SD}	V _{GS} =0V, I _S =1A, T _J =25°C	---	---	1	V
Reverse Recovery Time	t _{rr}	I _F =15A, di/dt=100A/μs, T _J =25°C	---	34	---	nS
Reverse Recovery Charge	Q _{rr}		---	15	---	nC

Note:

- 1.The data tested by surface mounted on a 1 inch² FR-4 board with 2OZ copper.
- 2.The data tested by pulsed, pulse width ≤ 300us, duty cycle ≤ 2%
- 3.The EAS data shows Max. rating. The test condition is V_{DD}=25V, V_{GS}=10V, L=0.1mH
- 4.The power dissipation is limited by 150°C junction temperature
- 5.The data is theoretically the same as I_D and I_{DM}, in real applications, should be limited by total power dissipation.

Typical Characteristics

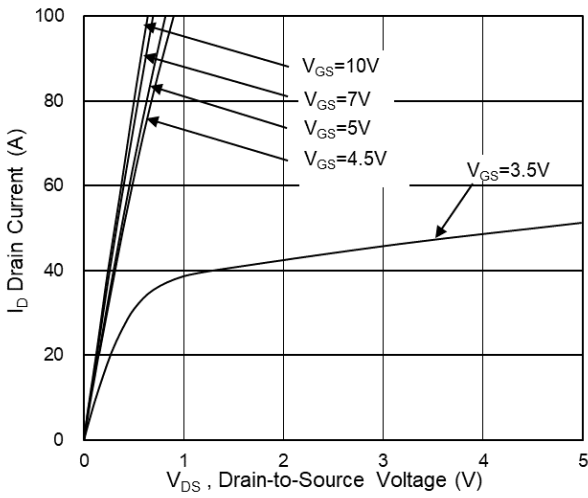

Fig.1 Typical Output Characteristics

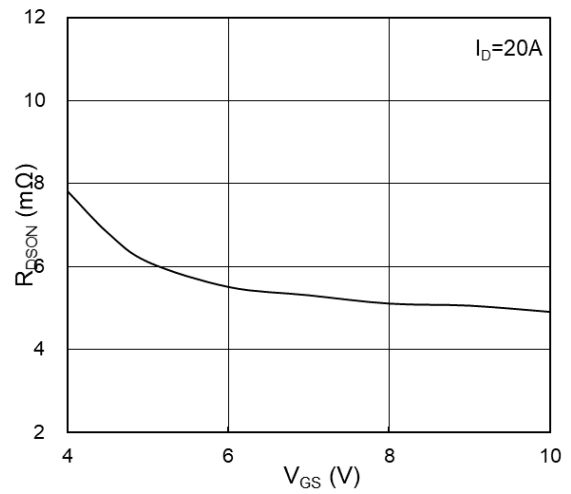

Fig.2 On-Resistance vs G-S Voltage

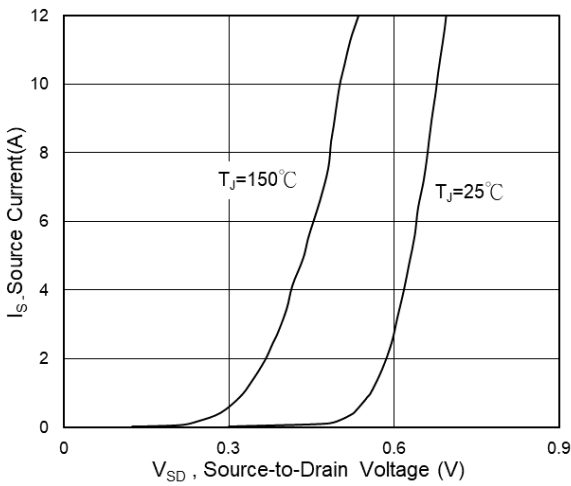

Fig.3 Source Drain Forward Characteristics

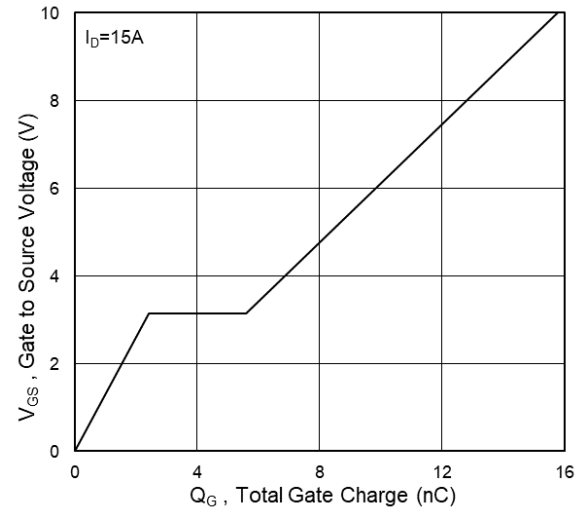

Fig.4 Gate-Charge Characteristics

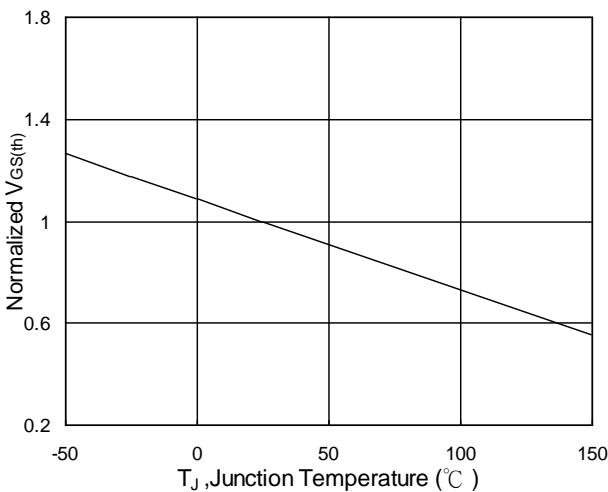

Fig.5 Normalized $V_{GS(th)}$ vs T_J

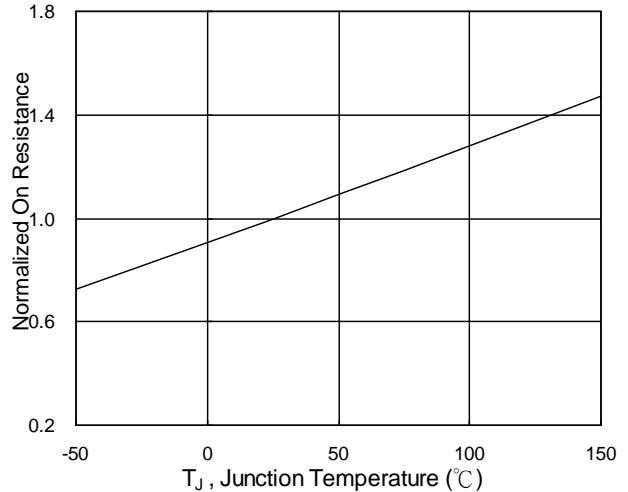

Fig.6 Normalized $R_{DS(on)}$ vs T_J

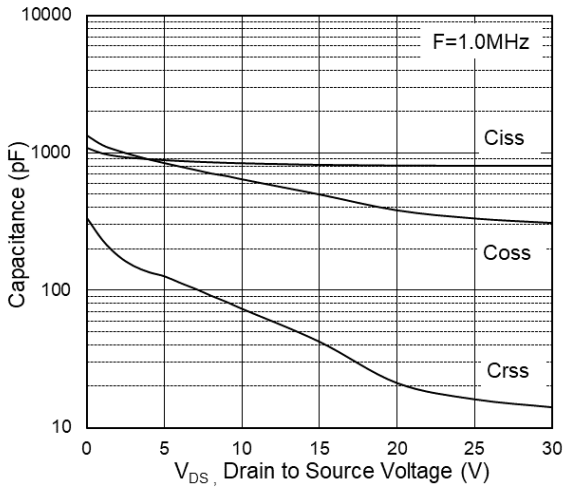

Fig.7 Capacitance

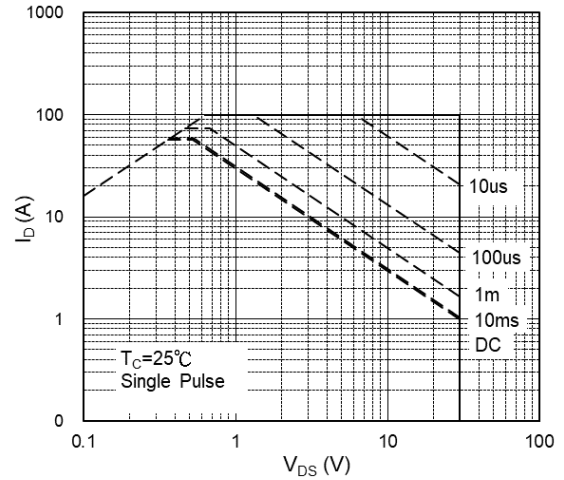

Fig.8 Safe Operating Area

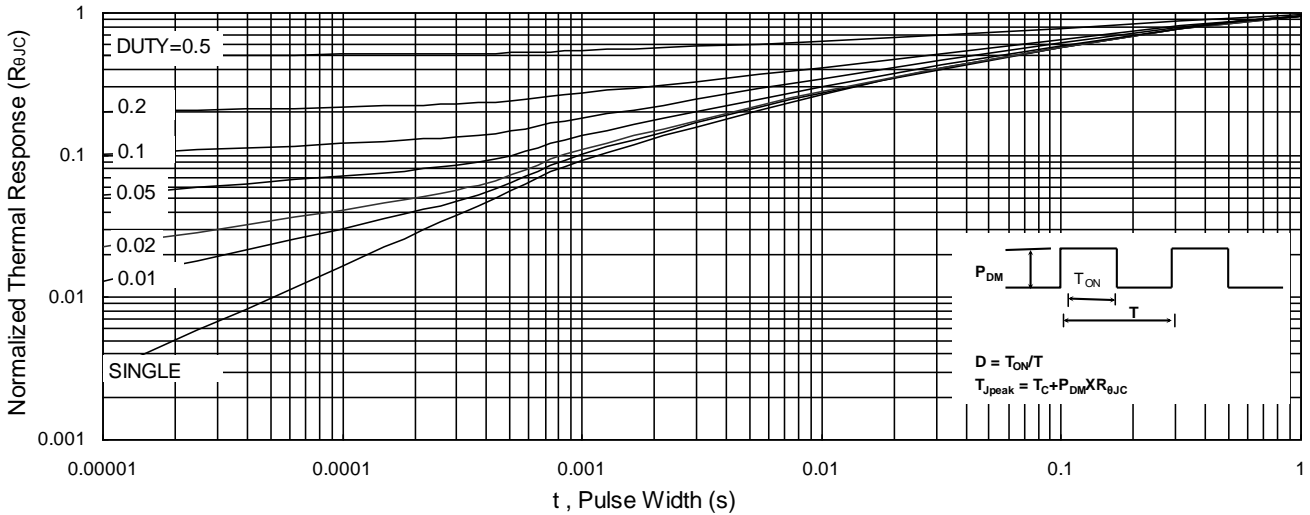

Fig.9 Normalized Maximum Transient Thermal Impedance

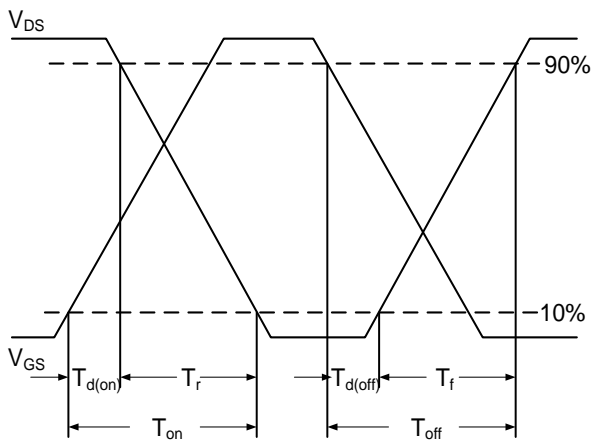

Fig.10 Switching Time Waveform

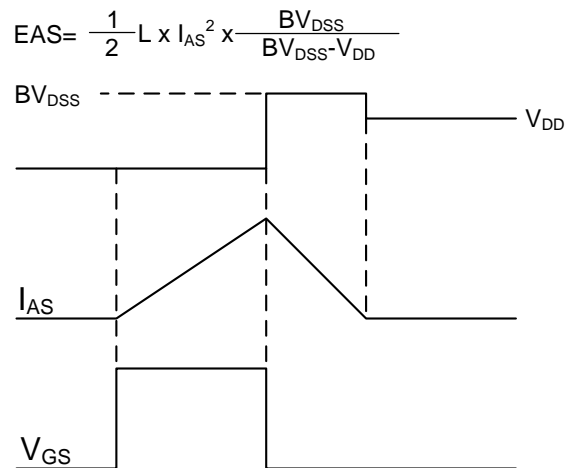
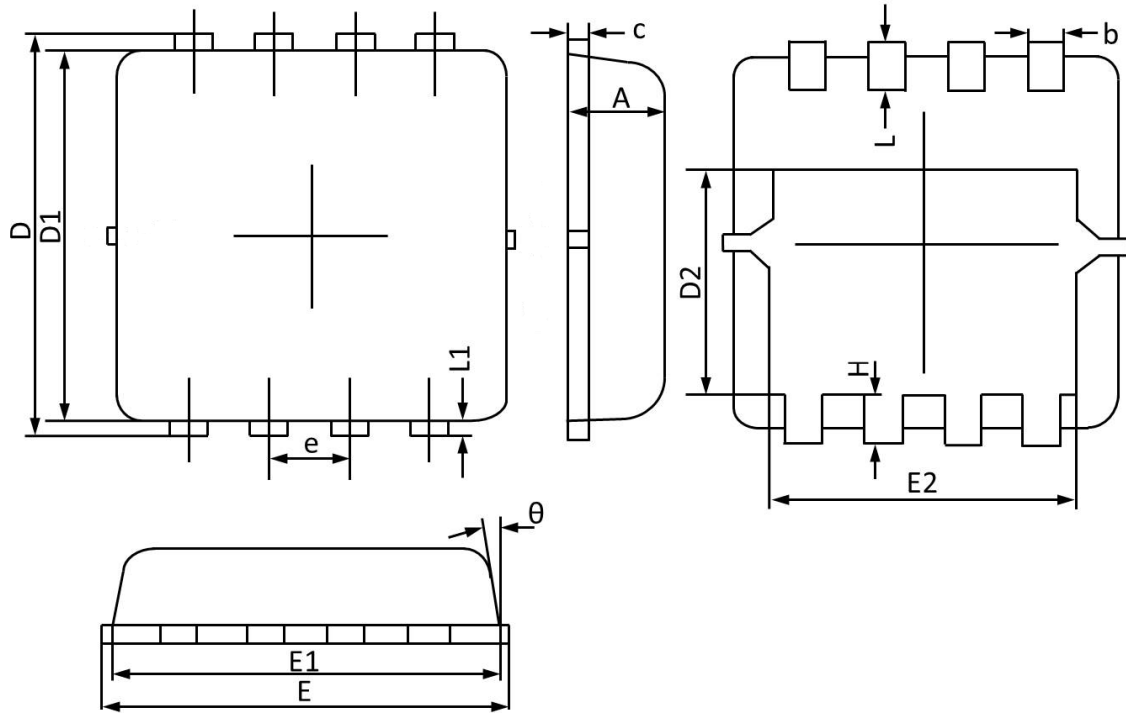

Fig.11 Unclamped Inductive Switching Waveform

DFN3X3-8L Package Outline Dimensions



Symbol	Dimensions (unit:mm)			Symbol	Dimensions (unit:mm)		
	Min	Typ	Max		Min	Typ	Max
A	0.70	0.75	0.85	E1	2.90	3.10	3.25
b	0.24	0.30	0.35	E2	2.35	2.50	2.60
c	0.10	0.17	0.25	e	0.65 BSC		
D	3.10	3.30	3.45	H	0.30	0.40	0.50
D1	2.90	3.05	3.20	L	0.30	0.40	0.50
D2	1.45	1.70	1.95	L1	--	0.13	--
E	3.05	3.25	3.40	theta	0°		14°