

Features

- Advanced high cell density Trench technology
- Super Low Gate Charge
- Excellent CdV/dt effect decline
- 100% EAS Guaranteed
- Green Device Available

Applications

- High Frequency Point-of-Load, Synchronous Buck Converter for MB/NB/UMPC/VGA
- Networking DC-DC Power System
- Load Switch

Product Summary



V_{DS}	30	V
I_D	9	A
$R_{DS(ON)}$ (at $V_{GS}=10V$)	12	m Ω
$R_{DS(ON)}$ (at $V_{GS}=4.5V$)	18	m Ω

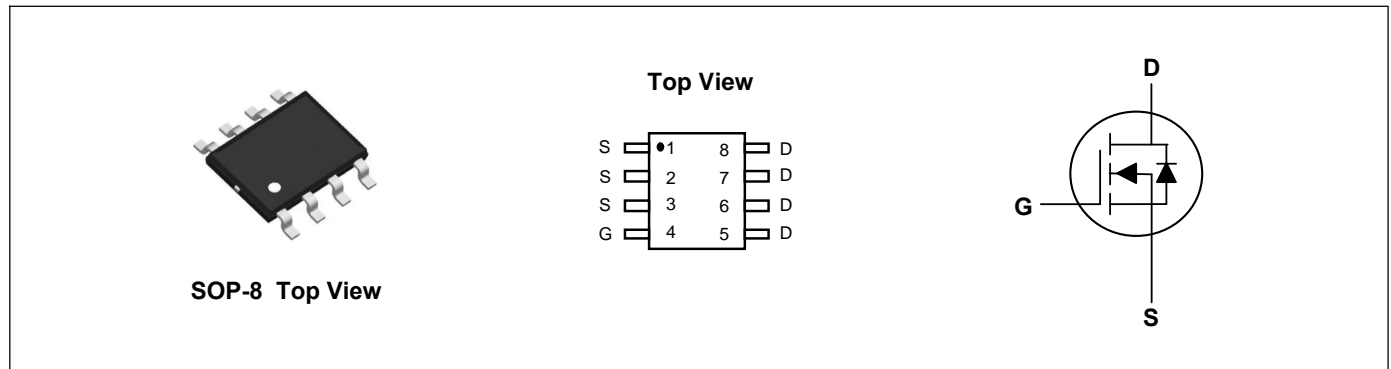

Absolute Maximum Ratings ($T_A=25^{\circ}C$, unless otherwise noted)

Parameter	Symbol	Rating	Units
Drain-Source Voltage	V_{DS}	30	V
Gate-Source Voltage	V_{GS}	± 20	V
Continuous Drain Current, $V_{GS} @ 10V^1$	$I_D @ T_A=25^{\circ}C$	9	A
Continuous Drain Current, $V_{GS} @ 10V^1$	$I_D @ T_A=70^{\circ}C$	7	A
Pulsed Drain Current ²	I_{DM}	36	A
Single Pulse Avalanche Energy ³	EAS	24.2	mJ
Avalanche Current	I_{AS}	22	A
Total Power Dissipation ⁴	$P_D @ T_A=25^{\circ}C$	1.5	W
Storage Temperature Range	T_{STG}	-55 to 150	$^{\circ}C$
Operating Junction Temperature Range	T_J	-55 to 150	$^{\circ}C$

Thermal Characteristics

Parameter	Symbol	Typ	Max	Unit
Thermal Resistance Junction-Ambient ¹	$R_{\theta JA}$	---	85	$^{\circ}C/W$
Thermal Resistance Junction-Case ¹	$R_{\theta JC}$	---	25	$^{\circ}C/W$

Electrical Characteristics (T_J=25°C, unless otherwise noted)

Parameter	Symbol	Conditions	Min	Typ	Max	Unit
Drain-Source Breakdown Voltage	BV _{DSS}	V _{GS} =0V, I _D =250uA	30	---	---	V
BV _{DSS} Temperature Coefficient	ΔBV _{DSS} /ΔT _J	Reference to 25°C, I _D =1mA	---	0.023	---	V/°C
Static Drain-Source On-Resistance ²	R _{DS(ON)}	V _{GS} =10V, I _D =8A	---	10	12	mΩ
		V _{GS} =4.5V, I _D =6A	---	15	18	mΩ
Gate Threshold Voltage	V _{GS(th)}	V _{GS} =V _{DS} , I _D =250uA	1.2	---	2.5	V
V _{GS(th)} Temperature Coefficient	ΔV _{GS(th)}		---	-5.08	---	mV/°C
Drain-Source Leakage Current	I _{DSS}	V _{DS} =24V, V _{GS} =0V, T _J =25°C	---	---	1	uA
		V _{DS} =24V, V _{GS} =0V, T _J =55°C	---	---	5	
Gate-Source Leakage Current	I _{GSS}	V _{GS} =±20V, V _{DS} =0V	---	---	±100	nA
Forward Transconductance	g _{fs}	V _{DS} =5V, I _D =8A	---	24	---	S
Gate Resistance	R _g	V _{DS} =0V, V _{GS} =0V, f=1MHz	---	1.8	3	Ω
Total Gate Charge (4.5V)	Q _g	V _{DS} =15V, V _{GS} =4.5V, I _D =8A	---	9.63	---	nC
Gate-Source Charge	Q _{gs}		---	3.88	---	
Gate-Drain Charge	Q _{gd}		---	3.44	---	
Turn-On Delay Time	T _{d(on)}	V _{DD} =15V, V _{GS} =10V, R _G =1.5Ω, I _D =8A	---	4.2	---	ns
Rise Time	T _r		---	8.2	---	
Turn-Off Delay Time	T _{d(off)}		---	31	---	
Fall Time	T _f		---	4	---	
Input Capacitance	C _{iss}	V _{DS} =15V, V _{GS} =0V, f=1MHz	---	940	---	pF
Output Capacitance	C _{oss}		---	131	---	
Reverse Transfer Capacitance	C _{rss}		---	109	---	

Drain-Source Diode Characteristics

Parameter	Symbol	Conditions	Min	Typ	Max	Unit
Continuous Source Current ^{1,5}	I _S	V _G =V _D =0V, Force Current	---	---	9	A
Pulsed Source Current ^{2,5}	I _{SM}		---	---	36	A
Diode Forward Voltage ²	V _{SD}	V _{GS} =0V, I _S =1A, T _J =25°C	---	---	1	V
Reverse Recovery Time	t _{rr}	I _F =8A, di/dt=100A/μs, T _J =25°C	---	8	---	nS
Reverse Recovery Charge	Q _{rr}		---	2.9	---	nC

Note:

- The data tested by surface mounted on a 1 inch² FR-4 board with 2OZ copper.
- The data tested by pulsed, pulse width ≤ 300us, duty cycle ≤ 2%
- The EAS data shows Max. rating. The test condition is V_{DD}=25V, V_{GS}=10V, L=0.1mH, I_{AS}=22A
- The power dissipation is limited by 150°C junction temperature
- The data is theoretically the same as I_D and I_{DM}, in real applications, should be limited by total power dissipation.

Typical Characteristics

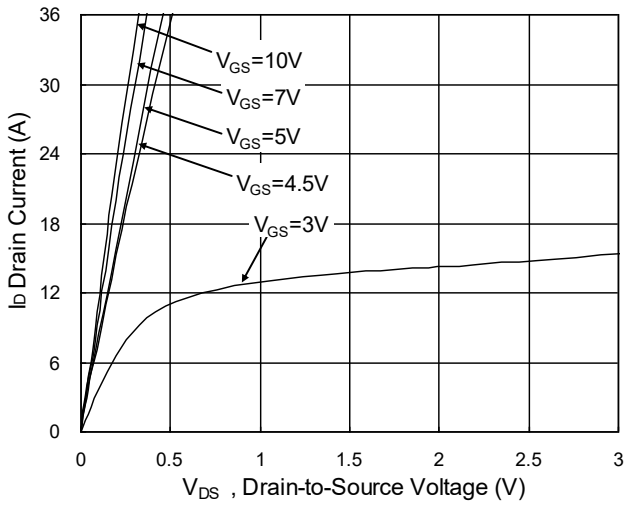

Fig.1 Typical Output Characteristics

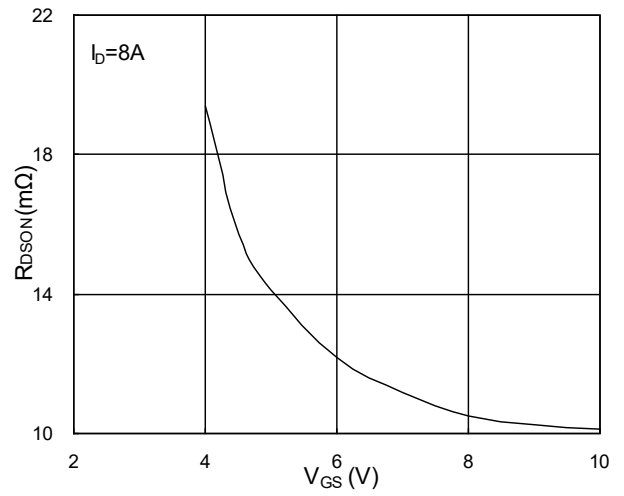

Fig.2 On-Resistance vs. G-S Voltage

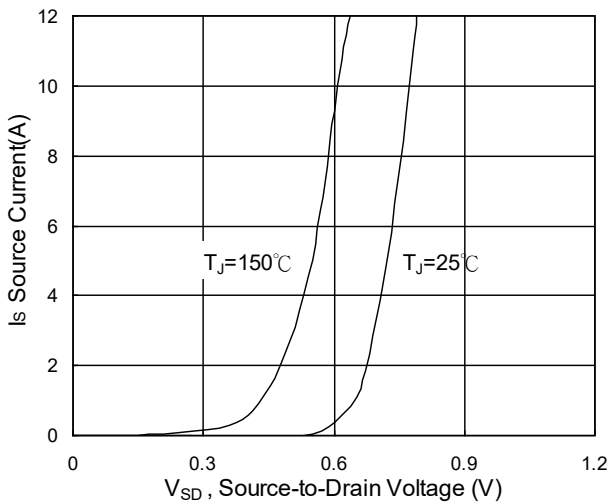

Fig.3 Forward Characteristics of Reverse

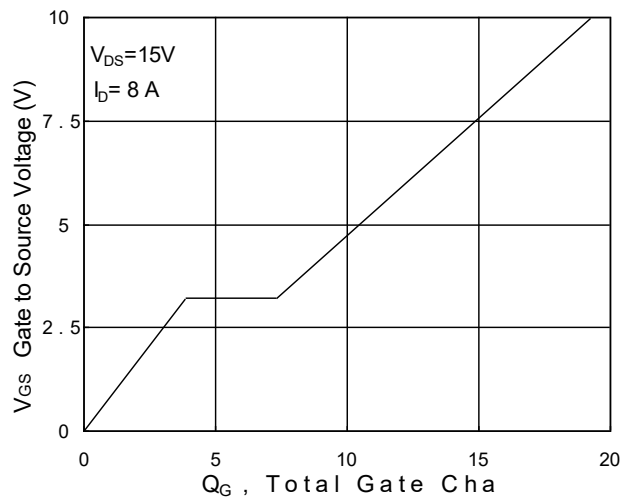

Fig.4 Gate-Charge Characteristics

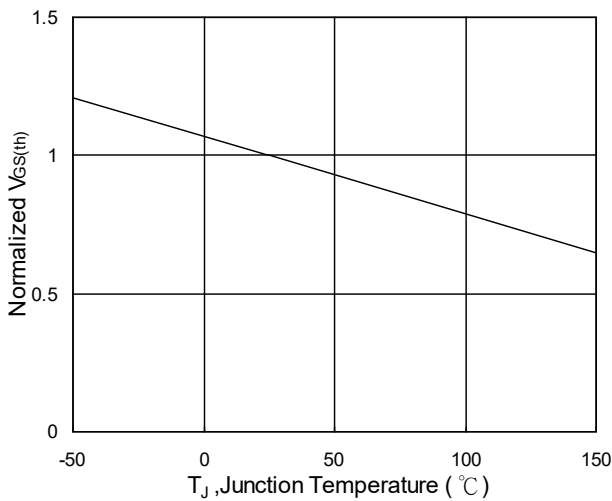

Fig.5 Normalized VGS(th) vs. TJ

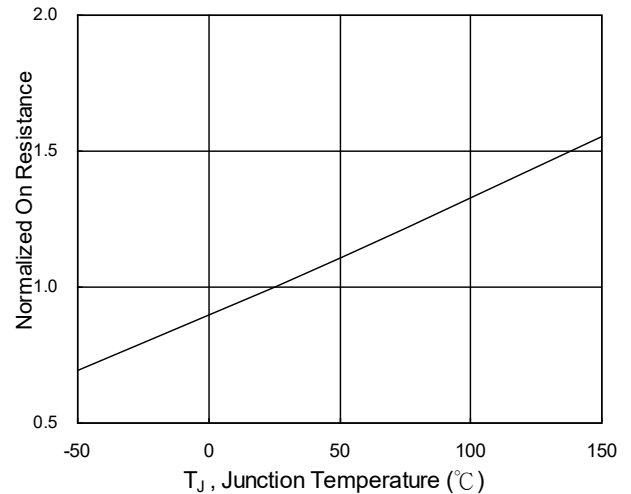

Fig.6 Normalized RDS(on) vs. TJ

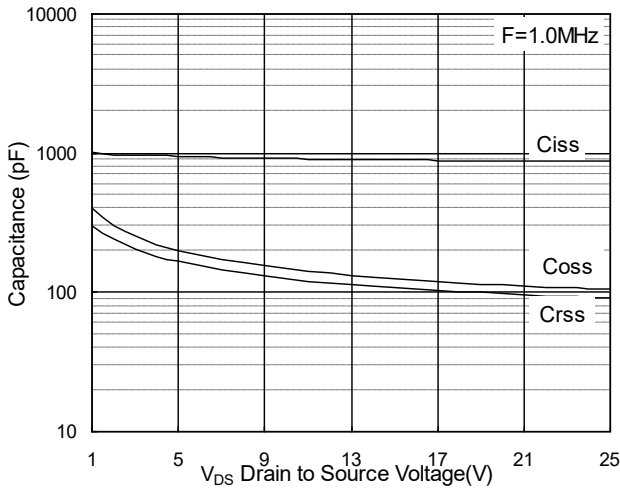

Fig.7 Capacitance

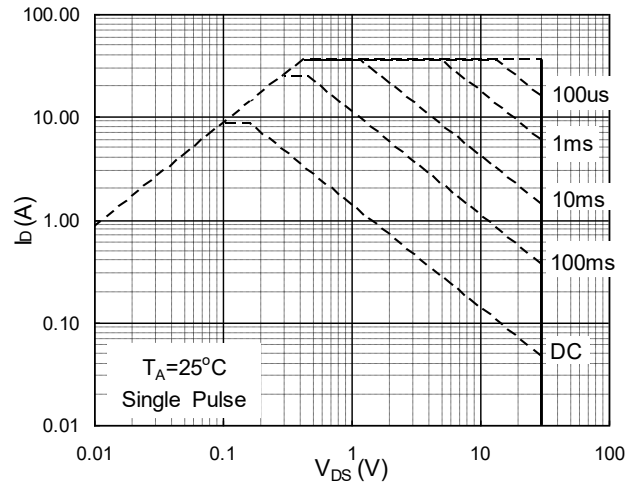

Fig.8 Safe Operating Area

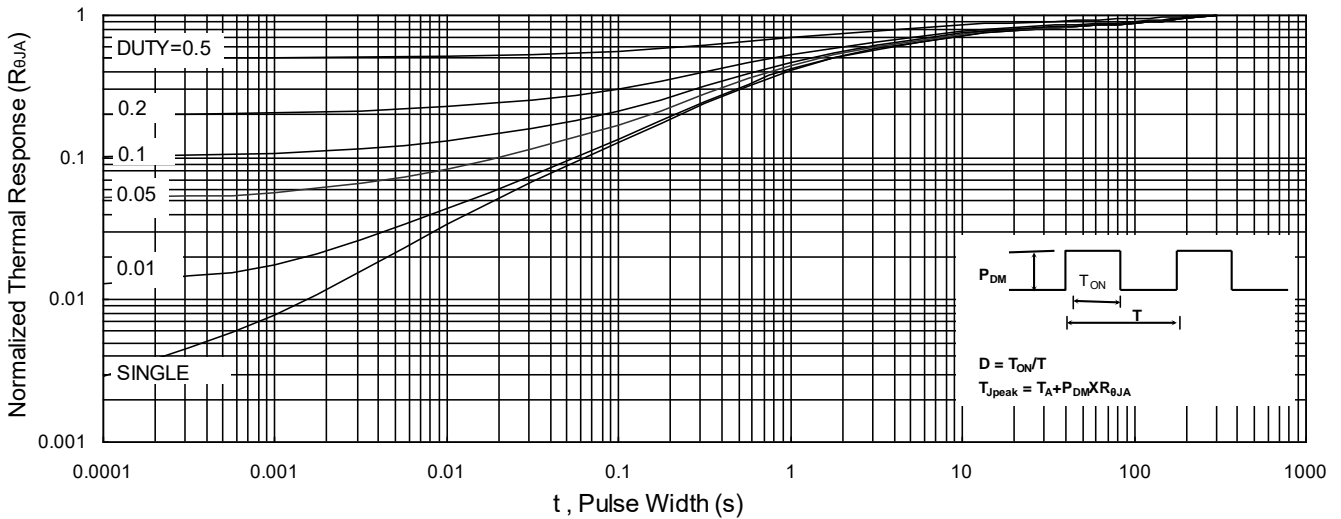

Fig.9 Normalized Maximum Transient Thermal Impedance

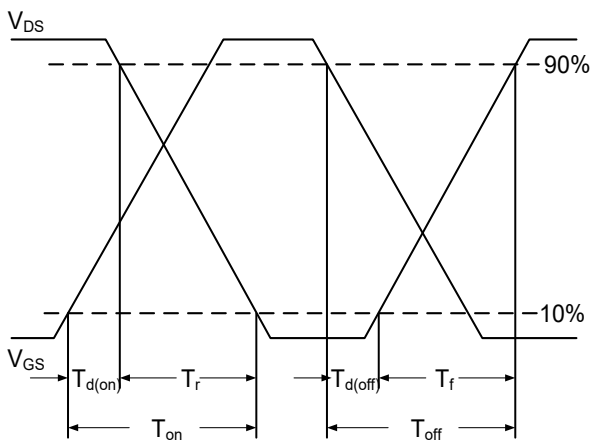

Fig.10 Switching Time Waveform

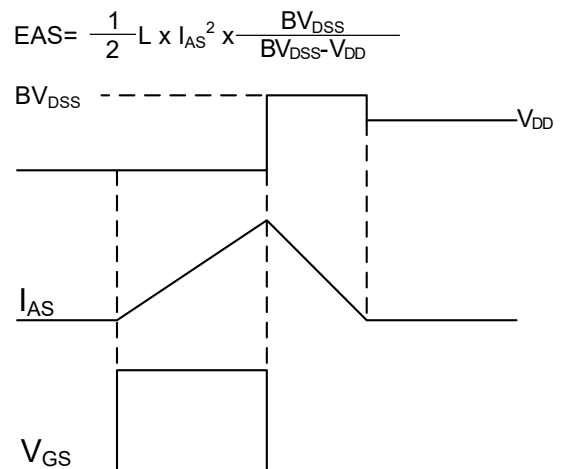
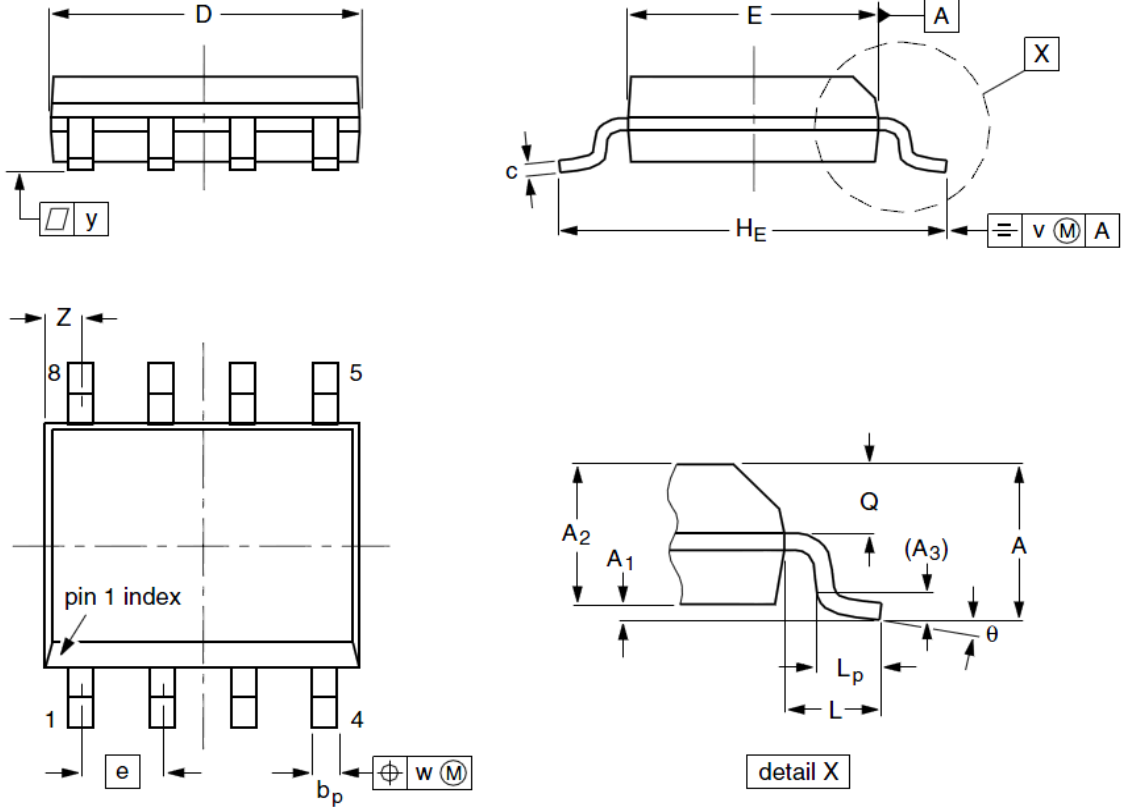

Fig.11 Unclamped Inductive Switching Waveform

SOP-8 Package Outline Dimensions



Symbol	Dimensions (unit:mm)			Symbol	Dimensions (unit:mm)		
	Min	Typ	Max		Min	Typ	Max
A	1.35	1.55	1.75	A₁	0.10	0.18	0.25
A₂	1.25	1.45	1.65	A₃	--	0.25	--
b_p	0.36	0.42	0.51	c	0.19	0.22	0.25
D	4.70	4.92	5.10	E	3.80	3.90	4.00
e	--	1.27	--	H_E	5.80	6.00	6.20
L	--	1.05	--	L_p	0.40	0.68	1.00
Q	0.60	0.65	0.73	v	--	0.25	--
w	--	0.25	--	y	--	0.10	--
Z	0.30	0.50	0.70	θ	0°		8°