

**Features**

- Advanced high cell density Trench technology
- Super Low Gate Charge
- Excellent CdV/dt effect decline
- Green Device Available

**Product Summary**



$V_{DS}$	-60	V
$I_D$	-3	A
$R_{DS(ON)}$ (at $V_{GS}=-10V$ )	200	m $\Omega$
$R_{DS(ON)}$ (at $V_{GS}=-4.5V$ )	266	m $\Omega$

**Applications**

- High Frequency Point-of-Load, Synchronous Buck Converter
- Networking DC-DC Power System
- Load Switch



**Absolute Maximum Ratings ( $T_C=25^\circ C$ , unless otherwise noted)**

Parameter	Symbol	Rating	Units
Drain-Source Voltage	$V_{DS}$	-60	V
Gate-Source Voltage	$V_{GS}$	$\pm 20$	V
Continuous Drain Current <sup>1</sup>	$I_D@T_C=25^\circ C$	-3	A
Continuous Drain Current <sup>1</sup>	$I_D@T_C=100^\circ C$	-1.4	A
Pulsed Drain Current <sup>2</sup>	$I_{DM}$	-7	A
Total Power Dissipation <sup>3</sup>	$P_D@T_C=25^\circ C$	1	W
Storage Temperature Range	$T_{STG}$	-55 to 150	$^\circ C$
Operating Junction Temperature Range	$T_J$	-55 to 150	$^\circ C$

**Thermal Characteristics**

Parameter	Symbol	Typ	Max	Unit
Thermal Resistance Junction-Ambient <sup>1</sup>	$R_{\theta JA}$	---	120	$^\circ C/W$
Thermal Resistance Junction-Case <sup>1</sup>	$R_{\theta JC}$	---	75	$^\circ C/W$

**Electrical Characteristics (T<sub>J</sub>=25°C, unless otherwise noted)**

Parameter	Symbol	Conditions	Min	Typ	Max	Unit
Drain-Source Breakdown Voltage	BV <sub>DSS</sub>	V <sub>GS</sub> =0V, I <sub>D</sub> =-250uA	-60	---	---	V
Static Drain-Source On-Resistance	R <sub>DS(ON)</sub>	V <sub>GS</sub> =-10V, I <sub>D</sub> =-1.5A	---	140	200	mΩ
		V <sub>GS</sub> =-4.5V, I <sub>D</sub> =-1A	---	180	266	mΩ
Gate Threshold Voltage	V <sub>GS(th)</sub>	V <sub>GS</sub> =V <sub>DS</sub> , I <sub>D</sub> =-250uA	-1.0	---	-2.5	V
Drain-Source Leakage Current	I <sub>DSS</sub>	V <sub>DS</sub> =-48V, V <sub>GS</sub> =0V, T <sub>J</sub> =25°C	---	---	1	uA
		V <sub>DS</sub> =-48V, V <sub>GS</sub> =0V, T <sub>J</sub> =55°C	---	---	5	uA
Gate-Source Leakage Current	I <sub>GSS</sub>	V <sub>GS</sub> =±20V, V <sub>DS</sub> =0V	---	---	±100	nA
Total Gate Charge	Q <sub>g</sub>	V <sub>DS</sub> =-20V, V <sub>GS</sub> =-4.5V, I <sub>D</sub> =-1.5A	---	4.6	---	nC
Gate-Source Charge	Q <sub>gs</sub>		---	1.4	---	
Gate-Drain Charge	Q <sub>gd</sub>		---	1.62	---	
Turn-On Delay Time	T <sub>d(on)</sub>	V <sub>DS</sub> =-15V, V <sub>GS</sub> =-10V, R <sub>G</sub> =3.3Ω, I <sub>D</sub> =-1A	---	17.4	---	ns
Rise Time	T <sub>r</sub>		---	5.4	---	
Turn-Off Delay Time	T <sub>d(off)</sub>		---	37.2	---	
Fall Time	T <sub>f</sub>		---	2.4	---	
Input Capacitance	C <sub>iss</sub>	V <sub>DS</sub> =-15V, V <sub>GS</sub> =0V, f=1MHz	---	531	---	pF
Output Capacitance	C <sub>oss</sub>		---	59	---	
Reverse Transfer Capacitance	C <sub>rss</sub>		---	38	---	

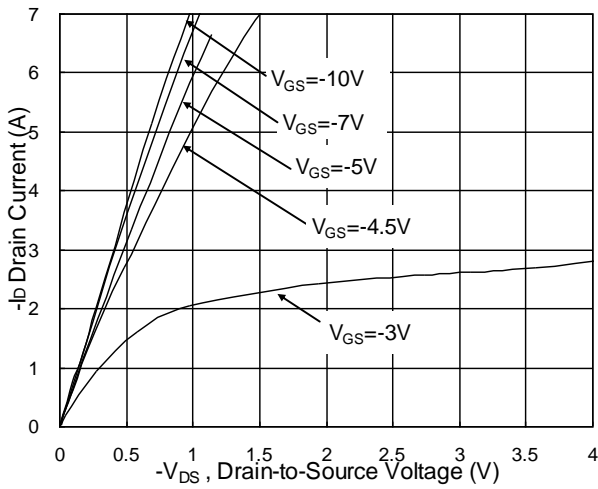
**Drain-Source Diode Characteristics**

Parameter	Symbol	Conditions	Min	Typ	Max	Unit
Continuous Source Current <sup>1</sup>	I <sub>S</sub>	V <sub>G</sub> =V <sub>D</sub> =0V, Force Current	---	---	-1.7	A
Pulsed Source Current <sup>2</sup>	I <sub>SM</sub>		---	---	-7	A
Diode Forward Voltage <sup>2</sup>	V <sub>SD</sub>	V <sub>GS</sub> =0V, I <sub>S</sub> =-1A, T <sub>J</sub> =25°C	---	---	-1.2	V

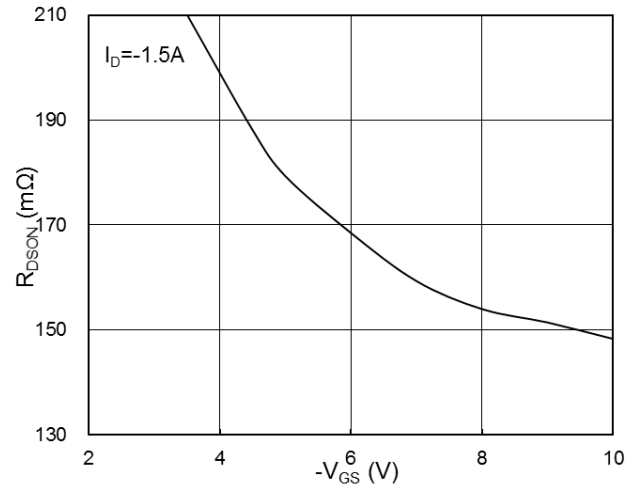
**Note:**

- 1.The data tested by surface mounted on a 1 inch<sup>2</sup> FR-4 board with 2OZ copper.
- 2.The data tested by pulsed, pulse width ≤ 300us, duty cycle ≤ 2%
- 3.The power dissipation is limited by 150°C junction temperature

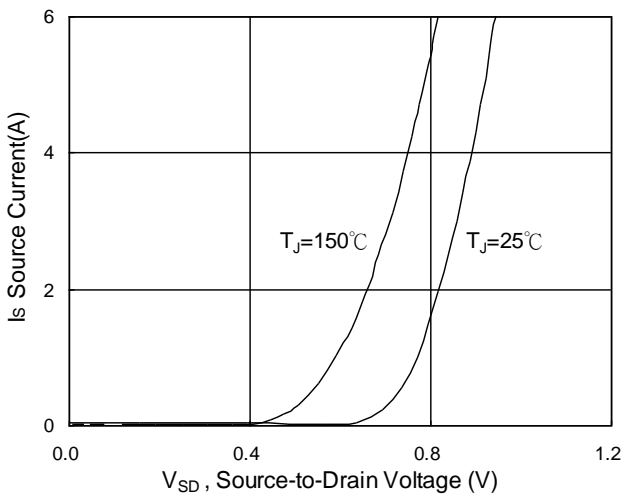
**Typical Characteristics**



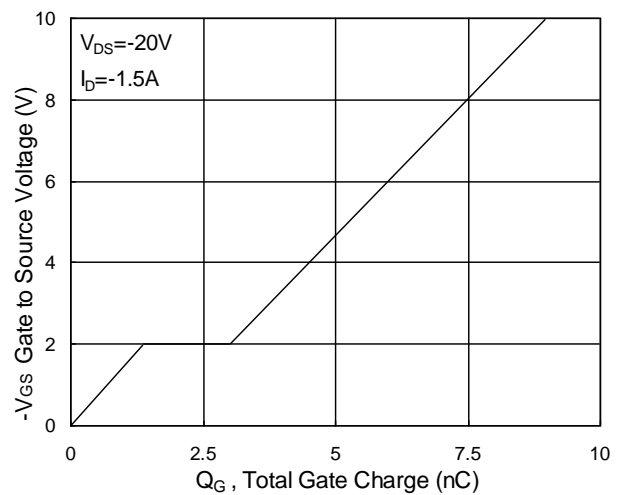
**Fig.1 Typical Output Characteristics**



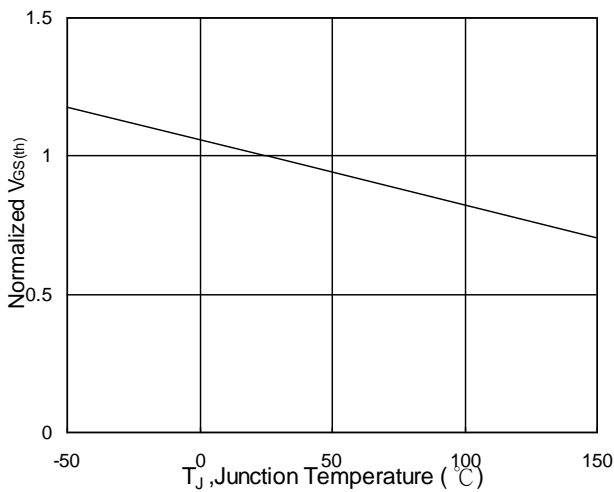
**Fig.2 On-Resistance v.s Gate-Source**



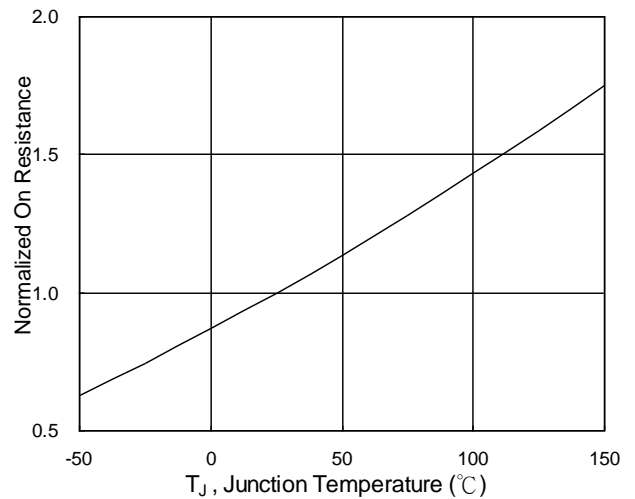
**Fig.3 Forward Characteristics Of Reverse**



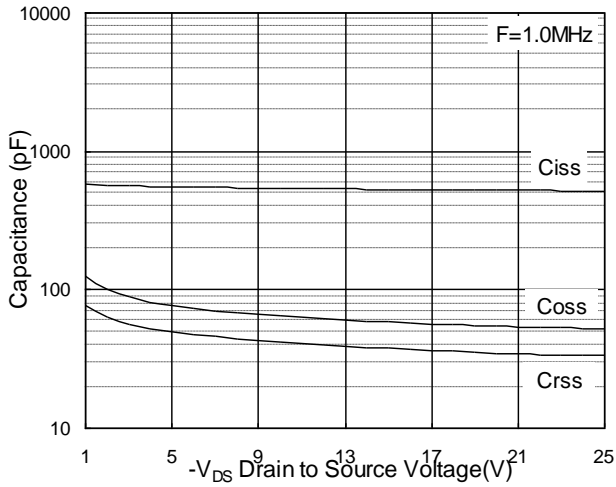
**Fig.4 Gate-Charge Characteristics**



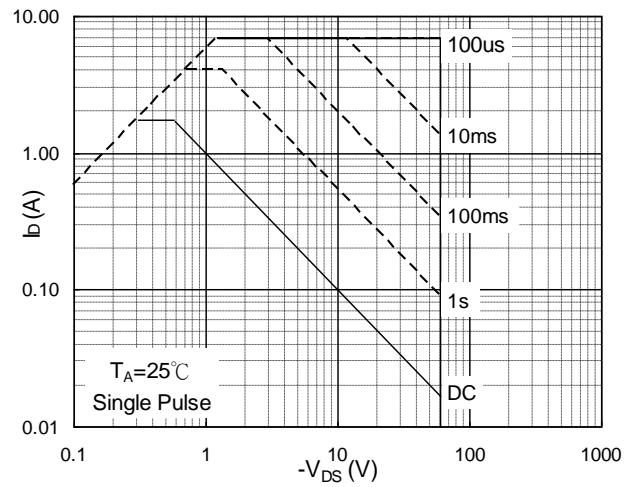
**Fig.5 Normalized  $V_{GS(th)}$  v.s  $T_J$**



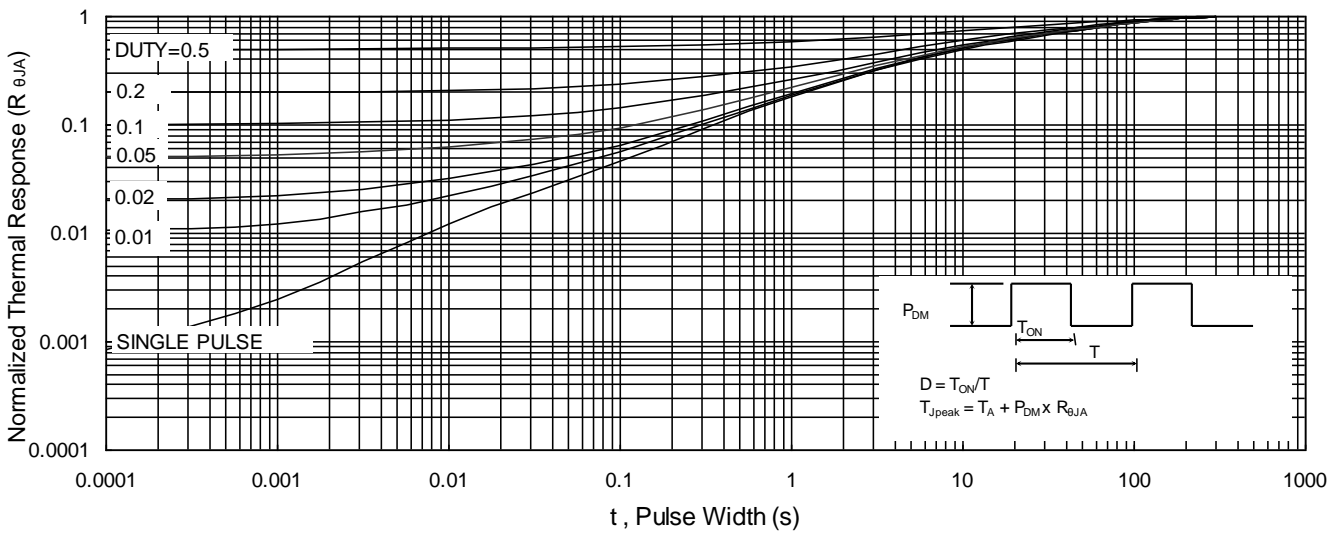
**Fig.6 Normalized  $R_{DS(on)}$  v.s  $T_J$**



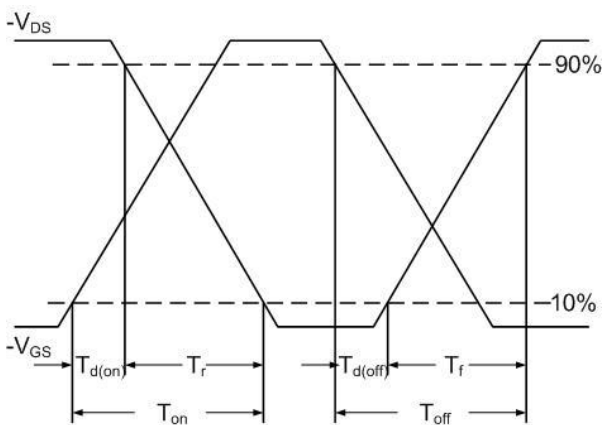
**Fig.7 Capacitance**



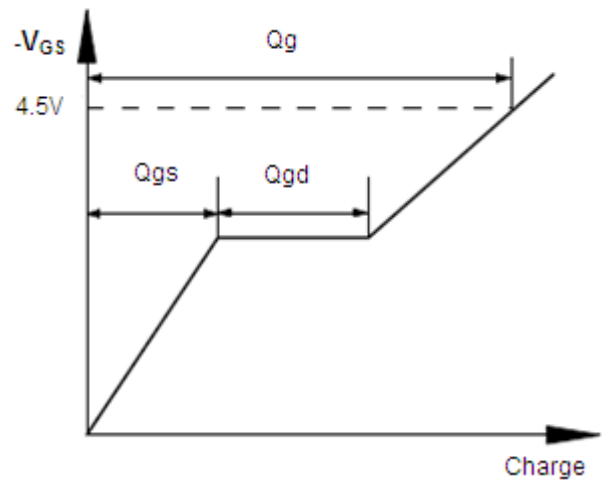
**Fig.8 Safe Operating Area**



**Fig.9 Normalized Maximum Transient Thermal Impedance**

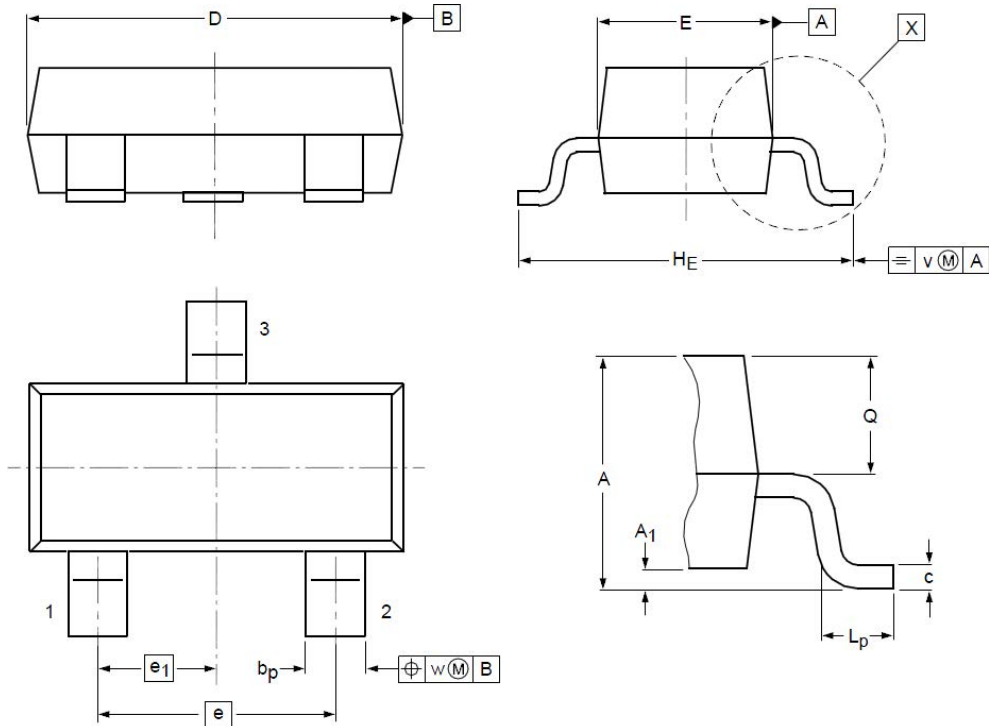


**Fig.10 Switching time waveform**



**Fig.11 Gate Charge waveform**

**SOT23 Package Outline Dimensions**



Symbol	Dimensions (unit:mm)			Symbol	Dimensions (unit:mm)		
	Min	Typ	Max		Min	Typ	Max
<b>A</b>	0.90	1.05	1.20	<b>e<sub>1</sub></b>	--	0.95	--
<b>A<sub>1</sub></b>	0.01	0.05	0.10	<b>H<sub>E</sub></b>	2.10	2.40	2.50
<b>b<sub>p</sub></b>	0.38	0.42	0.48	<b>L<sub>p</sub></b>	0.40	0.50	0.60
<b>c</b>	0.09	0.13	0.15	<b>Q</b>	0.45	0.49	0.55
<b>D</b>	2.80	2.92	3.00	<b>V</b>	--	0.20	--
<b>E</b>	1.20	1.33	1.40	<b>W</b>	--	0.10	--
<b>e</b>	--	1.90	--				