

Features

- Advanced high cell density Trench technology
- Super Low Gate Charge
- Excellent CdV/dt effect decline
- Green Device Available

Product Summary



V_{DS}	-30	V
I_D	-70	A
$R_{DS(ON)}$ (at $V_{GS}=-10V$)	7.2	m Ω
$R_{DS(ON)}$ (at $V_{GS}=-4.5V$)	12	m Ω

Applications

- High Frequency Point-of-Load, Synchronous Buck Converter for MB/NB/UMPC/VGA
- Networking DC-DC Power System
- Load Switch

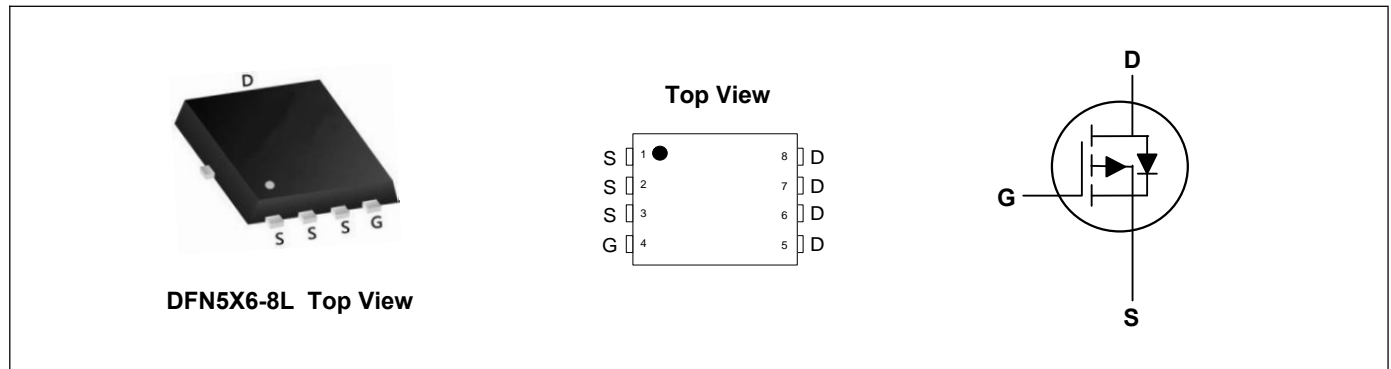

Absolute Maximum Ratings ($T_C=25^\circ\text{C}$, unless otherwise noted)

Parameter	Symbol	Rating	Units
Drain-Source Voltage	V_{DS}	-30	V
Gate-Source Voltage	V_{GS}	± 20	V
Continuous Drain Current, $V_{GS} @ -10V^{1,6}$	$I_D @ T_C=25^\circ\text{C}$	-70	A
Continuous Drain Current, $V_{GS} @ -10V^{1,6}$	$I_D @ T_C=100^\circ\text{C}$	-50	A
Pulsed Drain Current ²	I_{DM}	-200	A
Single Pulse Avalanche Energy ³	EAS	80	mJ
Avalanche Current	I_{AS}	-40	A
Total Power Dissipation ⁴	$P_D @ T_C=25^\circ\text{C}$	90	W
Storage Temperature Range	T_{STG}	-55 to 175	$^\circ\text{C}$
Operating Junction Temperature Range	T_J	-55 to 175	$^\circ\text{C}$

Thermal Characteristics

Parameter	Symbol	Typ	Max	Unit
Thermal Resistance Junction-Ambient ¹ ($t \leq 10s$)	$R_{\theta JA}$	---	20	$^\circ\text{C/W}$
Thermal Resistance Junction-Ambient ¹ (Steady State)		---	50	$^\circ\text{C/W}$
Thermal Resistance Junction-Case ¹	$R_{\theta JC}$	---	1.6	$^\circ\text{C/W}$

Electrical Characteristics (T_J=25°C, unless otherwise noted)

Parameter	Symbol	Conditions	Min	Typ	Max	Unit
Drain-Source Breakdown Voltage	BV _{DSS}	V _{GS} =0V, I _D =-250uA	-30	---	---	V
Static Drain-Source On-Resistance ²	R _{DS(ON)}	V _{GS} =-10V, I _D =-20A	---	6	7.2	mΩ
		V _{GS} =-4.5V, I _D =-15A	---	9.5	12	mΩ
Gate Threshold Voltage	V _{GS(th)}	V _{GS} =V _{DS} , I _D =-250uA	-1.2	-1.5	-2.5	V
Drain-Source Leakage Current	I _{DSS}	V _{DS} =-24V, V _{GS} =0V, T _J =25°C	---	---	-1	uA
		V _{DS} =-24V, V _{GS} =0V, T _J =55°C	---	---	-5	
Gate-Source Leakage Current	I _{GSS}	V _{GS} =±20V, V _{DS} =0V	---	---	±100	nA
Gate Resistance	R _g	V _{DS} =0V, V _{GS} =0V, f=1MHz	---	1.2	---	Ω
Total Gate Charge (-10V)	Q _g	V _{DS} =-15V, V _{GS} =-10V, I _D =-18A	---	60	---	nC
Gate-Source Charge	Q _{gs}		---	9	---	
Gate-Drain Charge	Q _{gd}		---	15	---	
Turn-On Delay Time	T _{d(on)}	V _{DD} =-15V, V _{GS} =-10V, R _G =3.3Ω, I _D =-20A	---	17	---	ns
Rise Time	T _r		---	40	---	
Turn-Off Delay Time	T _{d(off)}		---	55	---	
Fall Time	T _f		---	13	---	
Input Capacitance	C _{iss}	V _{DS} =-25V, V _{GS} =0V, f=1MHz	---	3450	---	pF
Output Capacitance	C _{oss}		---	255	---	
Reverse Transfer Capacitance	C _{rss}		---	140	---	

Drain-Source Diode Characteristics

Parameter	Symbol	Conditions	Min	Typ	Max	Unit
Continuous Source Current ^{1,5}	I _S	V _G =V _D =0V, Force Current	---	---	-70	A
Diode Forward Voltage ²	V _{SD}	V _{GS} =0V, I _S =-1A, T _J =25°C	---	---	-1.2	V
Reverse Recovery Time	t _{rr}	I _F =-20A, di/dt=100A/μs, T _J =25°C	---	22	---	nS
Reverse Recovery Charge	Q _{rr}		---	72	---	nC

Note:

- 1.The data tested by surface mounted on a 1 inch² FR-4 board with 2OZ copper.
- 2.The data tested by pulsed, pulse width ≤ 300us, duty cycle ≤ 2%
- 3.The EAS data shows Max. rating. The test condition is V_{DD}=-50V, V_{GS}=-10V, L=0.1mH, I_{AS}=-40A
- 4.The power dissipation is limited by 150°C junction temperature
- 5.The data is theoretically the same as I_D and I_{DM}, in real applications, should be limited by total power dissipation.
- 6.The maximum current rating is package limited.

Typical Characteristics

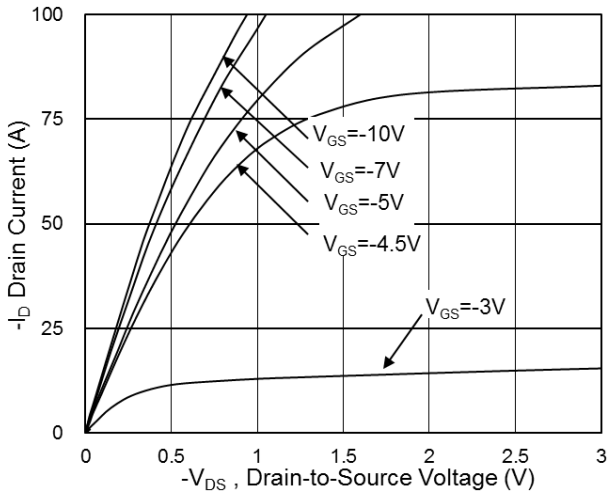

Fig.1 Typical Output Characteristics

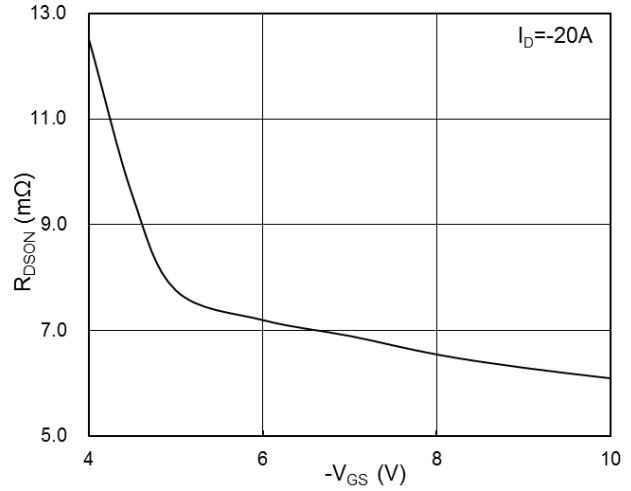

Fig.2 On-Resistance vs. Gate-Source Voltage

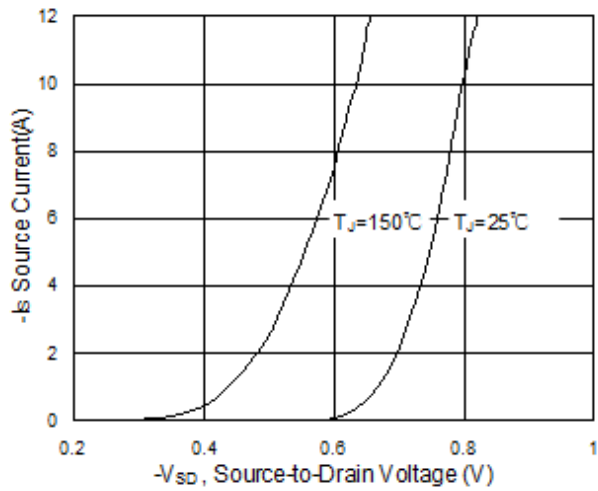

Fig.3 Forward Characteristics of Reverse

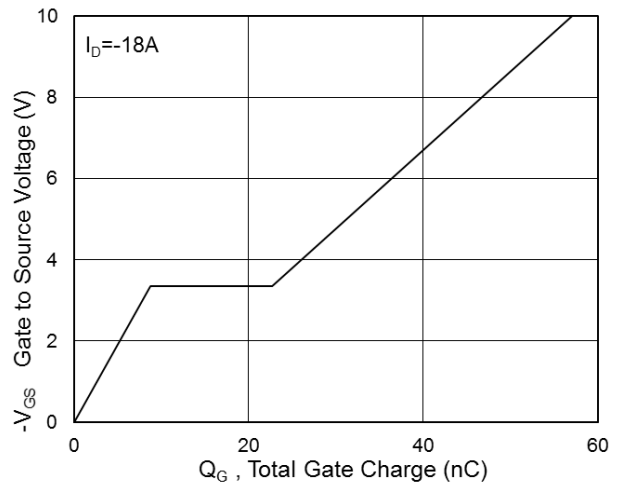

Fig.4 Gate-Charge Characteristics

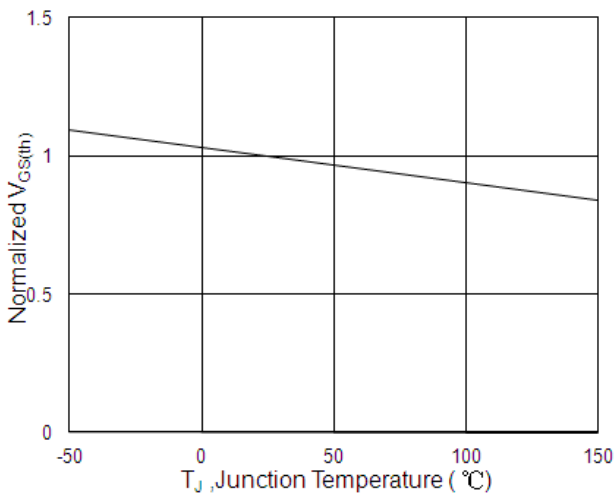

Fig.5 Normalized $-V_{GS(th)}$ vs. T_J

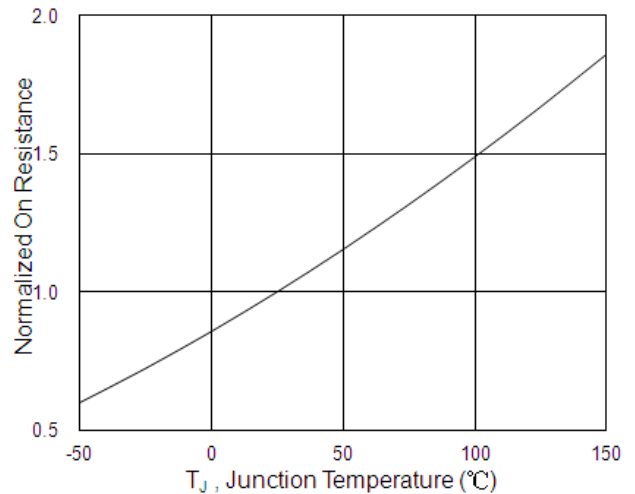

Fig.6 Normalized $R_{DS(on)}$ vs. T_J

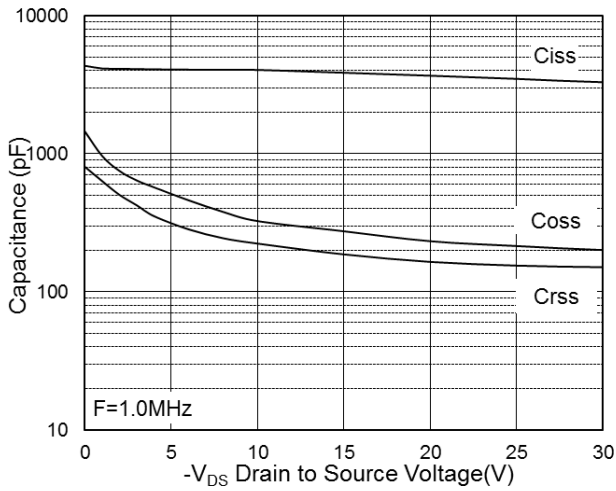

Fig.7 Capacitance

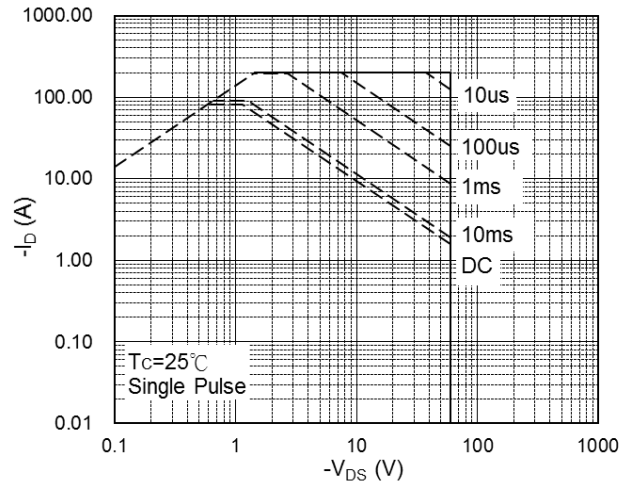

Fig.8 Safe Operating Area

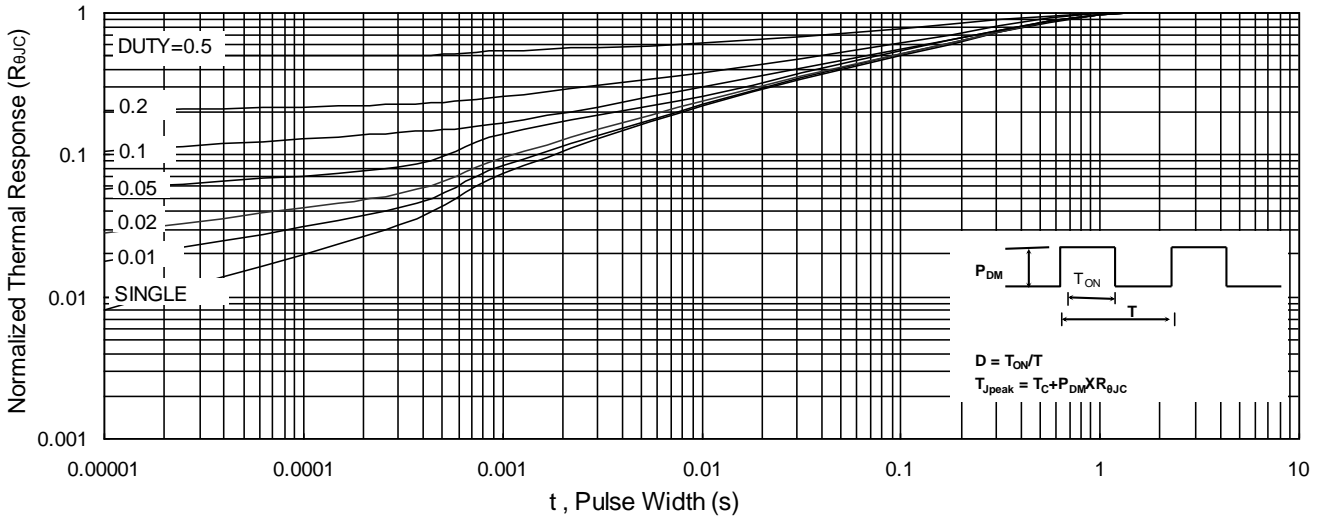

Fig.9 Normalized Maximum Transient Thermal Impedance

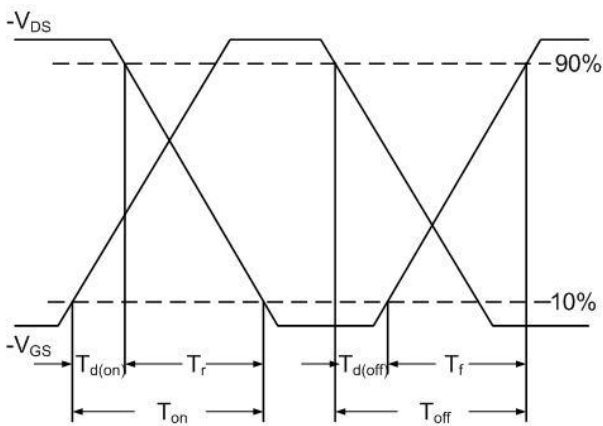

Fig.10 Switching Time Waveform

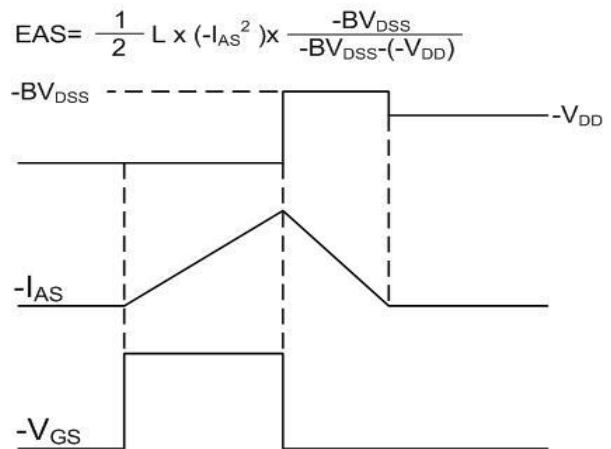
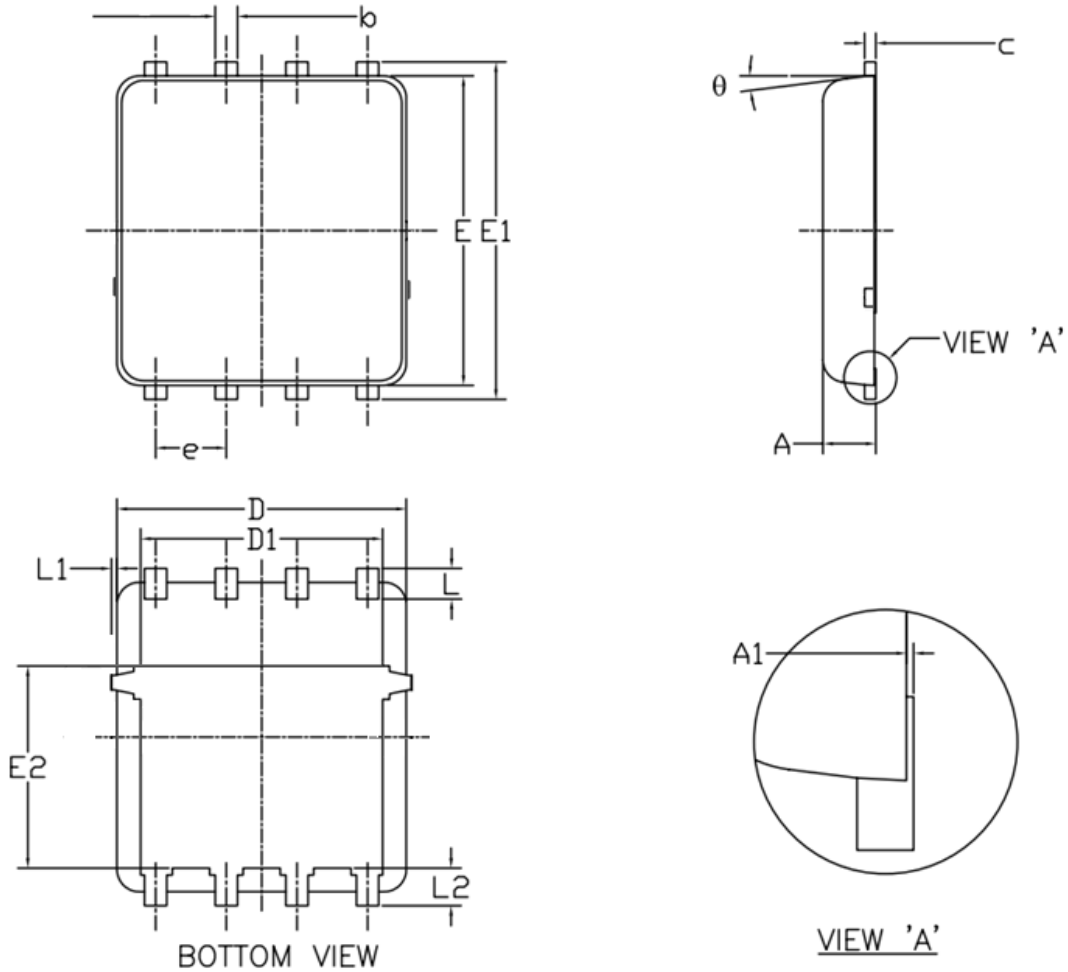

Fig.11 Unclamped Inductive Waveform

DFN5X6-8L Package Outline Dimensions



Symbol	Dimensions (unit:mm)			Symbol	Dimensions (unit:mm)		
	Min	Typ	Max		Min	Typ	Max
A	0.90	1.00	1.20	E1	5.90	6.10	6.35
A1	0.00	--	0.05	E2	3.38	3.58	3.92
b	0.30	0.40	0.51	e	1.27 BSC		
c	0.20	0.25	0.33	L	0.51	0.61	0.71
D	4.80	4.90	5.40	L1	--	--	0.15
D1	3.61	4.00	4.25	L2	0.41	0.51	0.61
E	5.65	5.80	6.06	θ	0°	--	12°