

**Features**

- Advanced high cell density Trench technology
- Super Low Gate Charge
- Excellent CdV/dt effect decline
- 100% EAS Guaranteed
- Green Device Available

**Applications**

- High Frequency Point-of-Load, Synchronous Buck Converter
- Networking DC-DC Power System
- Load Switch

**Product Summary**



$V_{DS}$	-30	V
$I_D$	-50	A
$R_{DS(ON)}$ (at $V_{GS}=-10V$ )	7	m $\Omega$

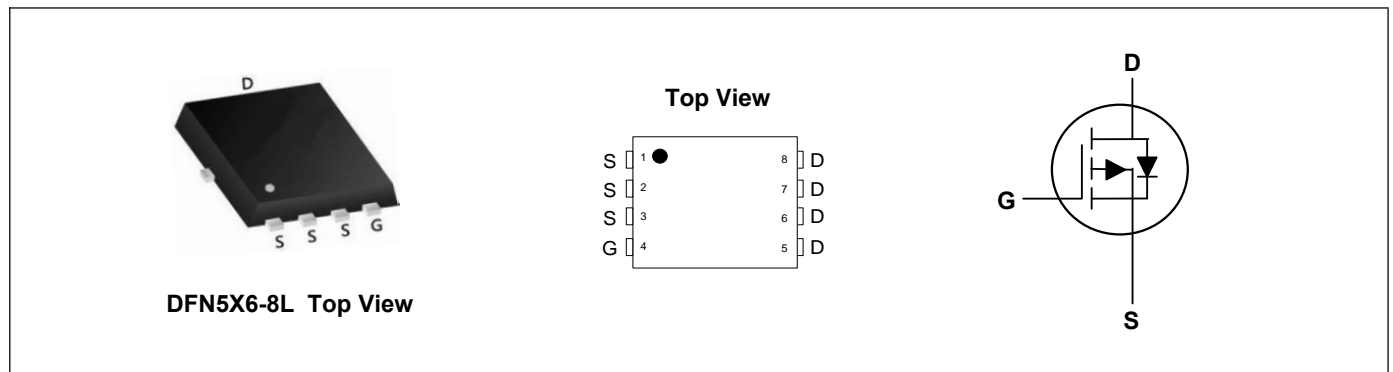

**Absolute Maximum Ratings( $T_c=25^{\circ}C$ , unless otherwise noted)**

Parameter	Symbol	Rating	Units
Drain-Source Voltage	$V_{DS}$	-30	V
Gate-Source Voltage	$V_{GS}$	$\pm 20$	V
Continuous Drain Current <sup>1</sup>	$I_D$	-50	A
Pulsed Drain Current <sup>2</sup>	$I_{DM}$	-70	A
Single Pulse Avalanche Energy <sup>3</sup>	EAS	300	mJ
Total Power Dissipation <sup>4</sup>	$P_D$	35	W
Storage Temperature Range	$T_{STG}$	-55 to 150	$^{\circ}C$
Operating Junction Temperature Range	$T_J$	-55 to 150	$^{\circ}C$

**Thermal Characteristics**

Parameter	Symbol	Typ	Max	Unit
Thermal Resistance Junction-Case <sup>1</sup>	$R_{\theta JC}$	---	3.6	$^{\circ}C/W$

**Electrical Characteristics ( $T_J=25^{\circ}\text{C}$ , unless otherwise noted)**

Parameter	Symbol	Conditions	Min	Typ	Max	Unit
Drain-Source Breakdown Voltage	$BV_{DSS}$	$V_{GS}=0V, I_D=-250\mu A$	-30	---	---	V
Static Drain-Source On-Resistance <sup>2</sup>	$R_{DS(ON)}$	$V_{GS}=-10V, I_D=-10A$	---	4.4	7	m $\Omega$
Gate Threshold Voltage	$V_{GS(th)}$	$V_{GS}=V_{DS}, I_D=-250\mu A$	-1.0	-1.5	-2.2	V
Drain-Source Leakage Current	$I_{DSS}$	$V_{DS}=-30V, V_{GS}=0V, T_J=25^{\circ}\text{C}$	---	---	-1	$\mu A$
Gate-Source Leakage Current	$I_{GSS}$	$V_{GS}=\pm 20V, V_{DS}=0V$	---	---	$\pm 100$	nA
Forward Transconductance	$g_{fs}$	$V_{DS}=-10V, I_D=-15A$	---	20	---	S
Total Gate Charge	$Q_g$	$V_{DS}=-15V, V_{GS}=-10V, I_D=-10A$	---	84	---	nC
Gate-Source Charge	$Q_{gs}$		---	11.7	---	
Gate-Drain Charge	$Q_{gd}$		---	25	---	
Turn-On Delay Time	$T_{d(on)}$	$V_{DD}=-15V, V_{GS}=-10V, R_G=6\Omega, I_D=-10A$	---	13	---	ns
Rise Time	$T_r$		---	12	---	
Turn-Off Delay Time	$T_{d(off)}$		---	50	---	
Fall Time	$T_f$		---	14	---	
Input Capacitance	$C_{iss}$	$V_{DS}=-15V, V_{GS}=0V, f=1\text{MHz}$	---	3590	---	pF
Output Capacitance	$C_{oss}$		---	695	---	
Reverse Transfer Capacitance	$C_{rss}$		---	660	---	

**Drain-Source Diode Characteristics**

Parameter	Symbol	Conditions	Min	Typ	Max	Unit
Continuous Source Current <sup>1</sup>	$I_S$	$T_C=25^{\circ}\text{C}$	---	---	-50	A
Diode Forward Voltage <sup>2</sup>	$V_{SD}$	$V_{GS}=0V, I_S=-10A, T_J=25^{\circ}\text{C}$	---	-0.85	-1.2	V
Reverse Recovery Time	$t_{rr}$	$I_F=-10A, di/dt=100A/\mu s, T_J=25^{\circ}\text{C}$	---	---	45	nS
Reverse Recovery Charge	$Q_{rr}$		---	---	43	nC

**Note:**

1. The data tested by surface mounted on a 1 inch<sup>2</sup> FR-4 board with 2OZ copper.
2. The data tested by pulsed, pulse width  $\leq 300\mu s$ , duty cycle  $\leq 2\%$
3. The EAS data shows Max. rating. The test condition is  $V_{DD}=-15V, V_{GS}=-10V, L=0.5\text{mH}$
4. The power dissipation is limited by 150 $^{\circ}\text{C}$  junction temperature

**Typical Characteristics**

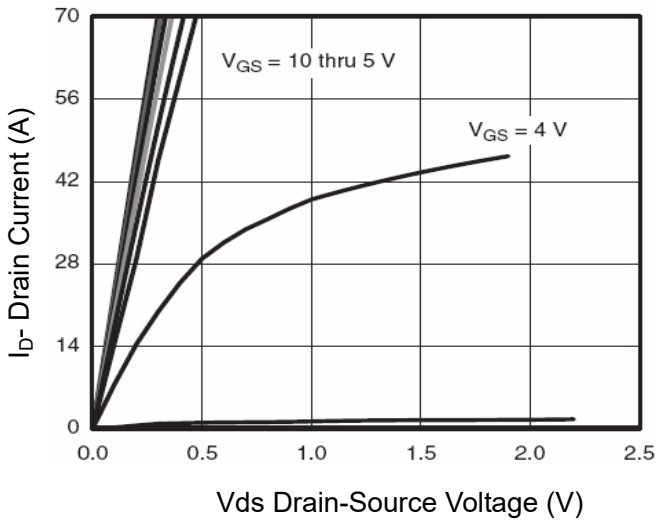

**Figure 1 Output Characteristics**

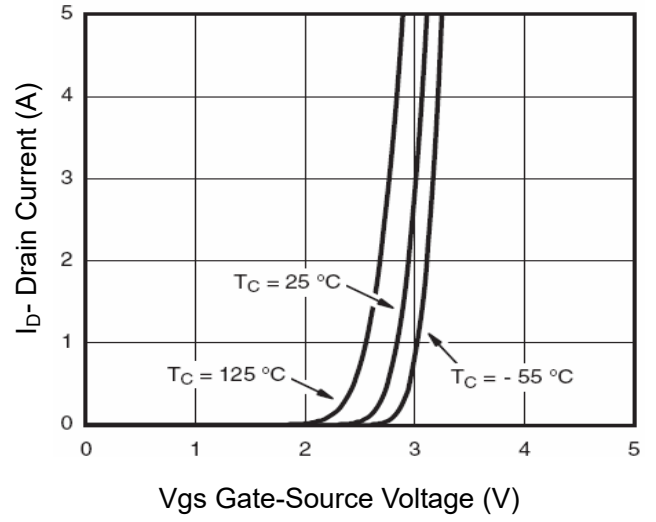

**Figure 2 Transfer Characteristics**

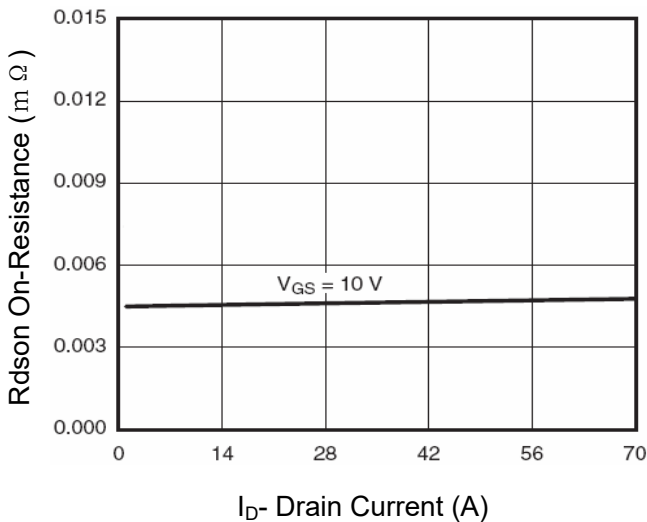

**Figure 3 Rdson- Drain Current**

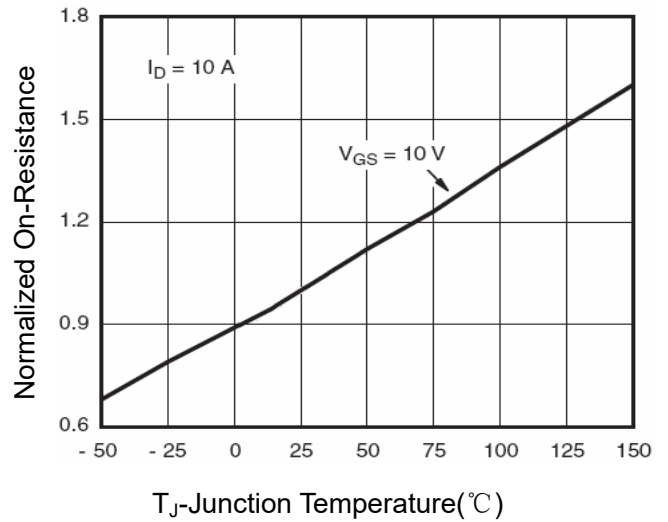

**Figure 4 Rdson-Junction Temperature**

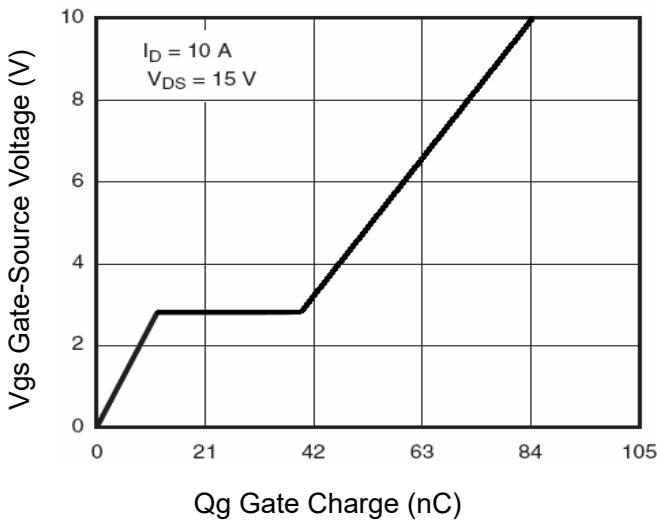

**Figure 5 Gate Charge**

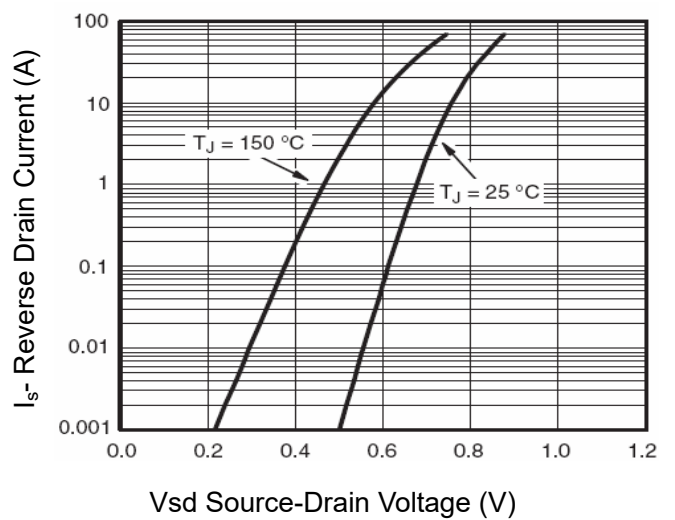

**Figure 6 Source- Drain Diode Forward**

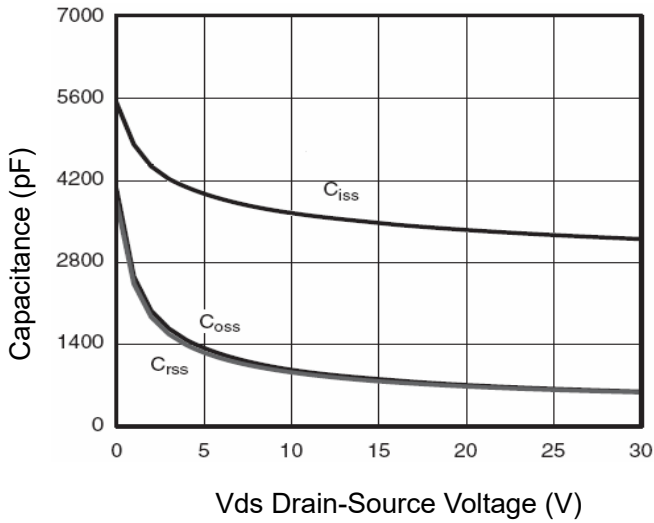

Vds Drain-Source Voltage (V)  
**Figure 7 Capacitance vs Vds**

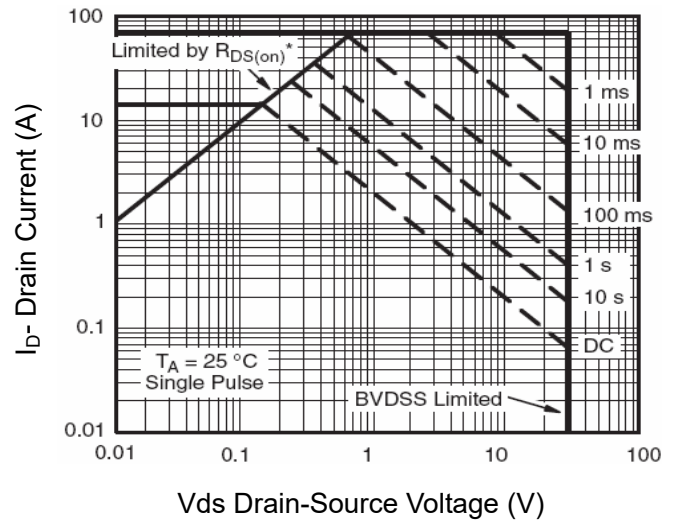

Vds Drain-Source Voltage (V)  
**Figure 8 Safe Operation Area**

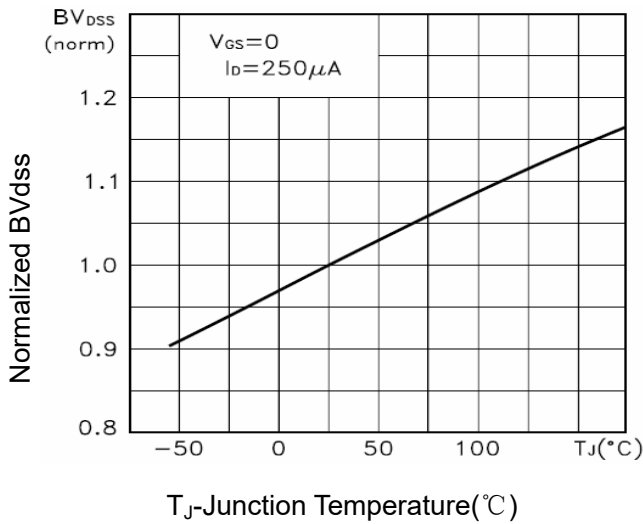

T<sub>J</sub>-Junction Temperature(°C)  
**Figure 9 BV<sub>DSS</sub> vs Junction Temperature**

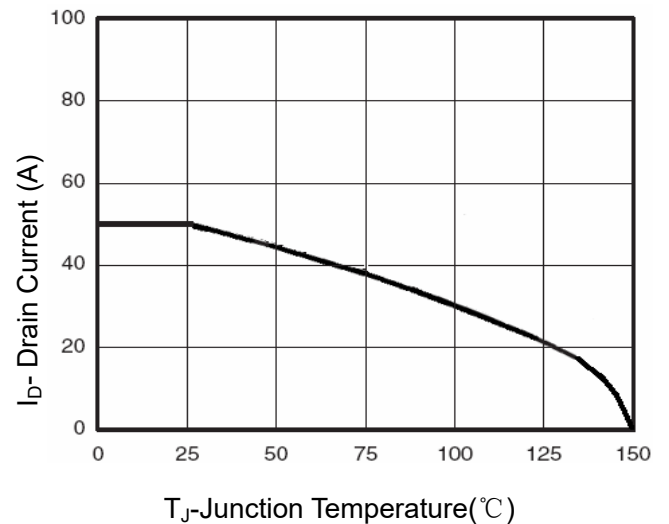

T<sub>J</sub>-Junction Temperature(°C)  
**Figure 10 ID Current Derating vs Junction Temperature**

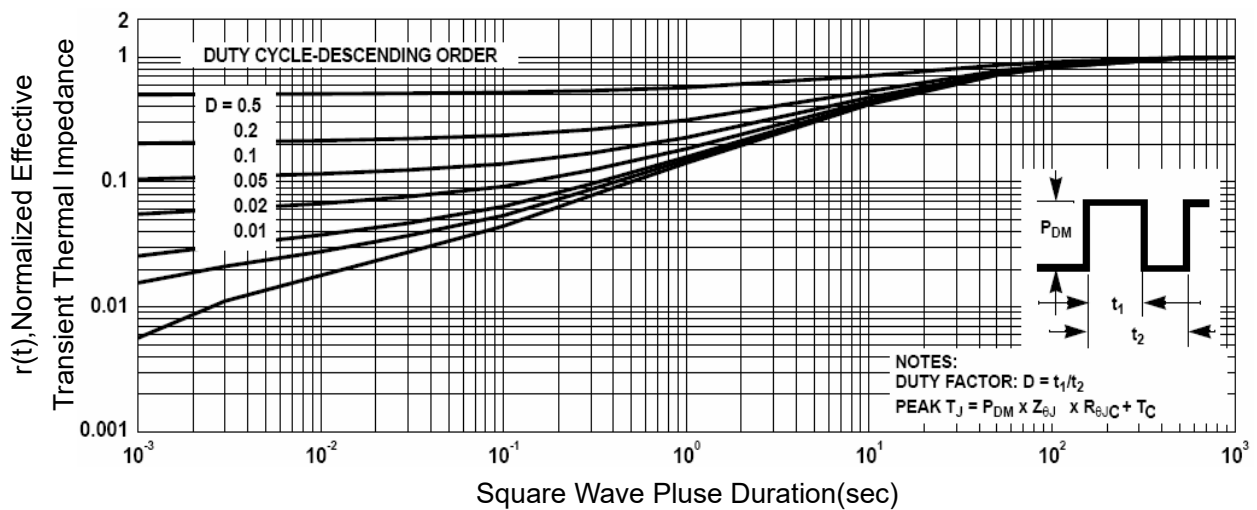

**Figure 11 Normalized Maximum Transient Thermal Impedance**

**DFN5X6-8L Package Outline Dimensions**

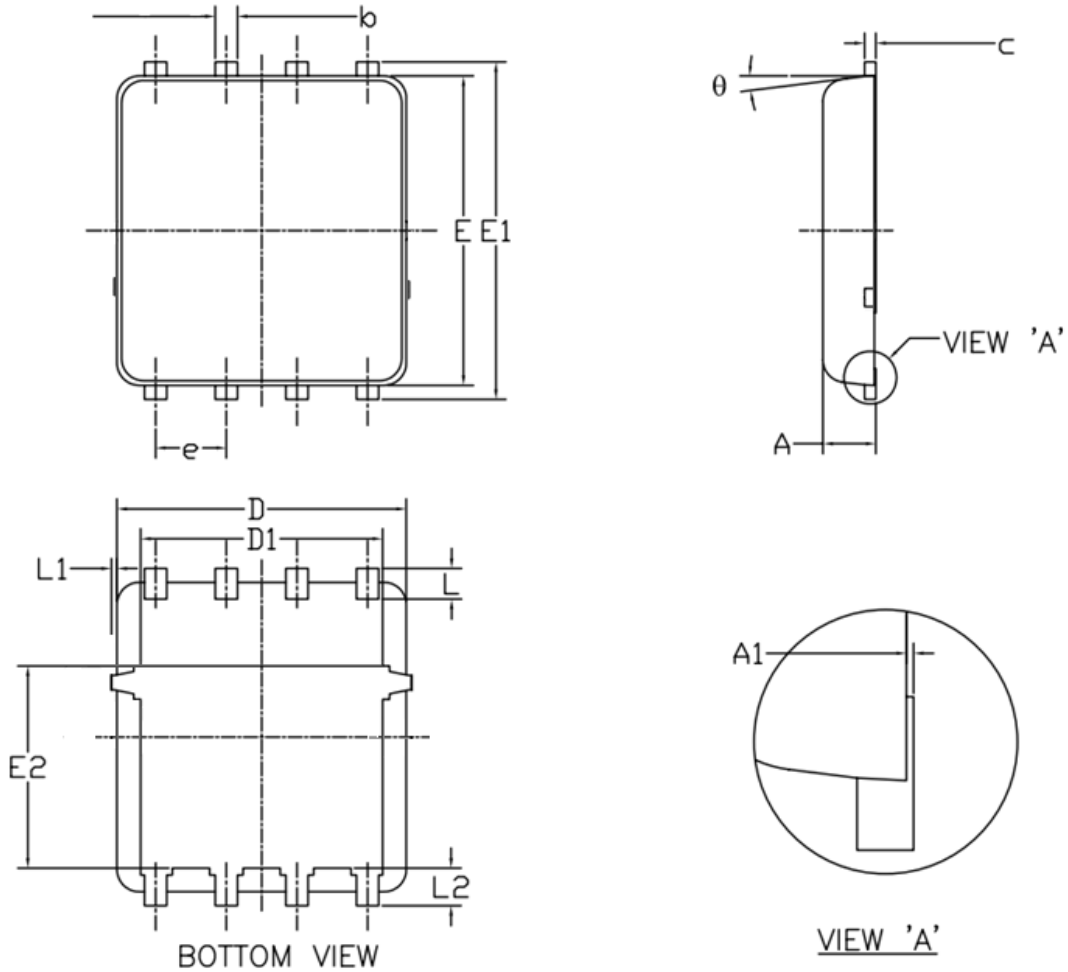

Symbol	Dimensions (unit:mm)			Symbol	Dimensions (unit:mm)		
	Min	Typ	Max		Min	Typ	Max
<b>A</b>	0.90	1.00	1.20	<b>E1</b>	5.90	6.10	6.35
<b>A1</b>	0.00	--	0.05	<b>E2</b>	3.38	3.58	3.92
<b>b</b>	0.30	0.40	0.51	<b>e</b>	1.27 BSC		
<b>c</b>	0.20	0.25	0.33	<b>L</b>	0.51	0.61	0.71
<b>D</b>	4.80	4.90	5.40	<b>L1</b>	--	--	0.15
<b>D1</b>	3.61	4.00	4.25	<b>L2</b>	0.41	0.51	0.61
<b>E</b>	5.65	5.80	6.06	<b>theta</b>	0°	--	12°