

**Features**

- Advanced high cell density Trench technology
- Super Low Gate Charge
- Excellent CdV/dt effect decline
- Green Device Available

**Product Summary**



$V_{DS}$	-30	V
$I_D$	-25	A
$R_{DS(ON)}$ (at $V_{GS}=-10V$ )	7	m $\Omega$

**Applications**

- High Frequency Point-of-Load, Synchronous Buck Converter
- Networking DC-DC Power System
- Load Switch

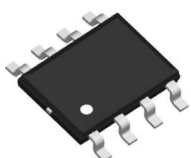

**SOP-8 Top View**

**Top View**

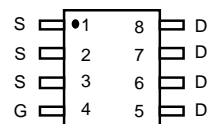

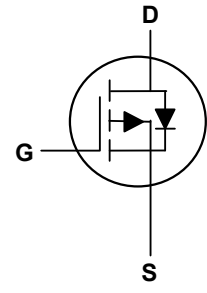

**Absolute Maximum Ratings( $T_A=25^{\circ}C$ , unless otherwise noted)**

Parameter	Symbol	Rating	Units
Drain-Source Voltage	$V_{DS}$	-30	V
Gate-Source Voltage	$V_{GS}$	$\pm 20$	V
Continuous Drain Current	$I_D$	-25	A
Pulsed Drain Current <sup>2</sup>	$I_{DM}$	-70	A
Total Power Dissipation <sup>3</sup>	$P_D$	3.5	W
Storage Temperature Range	$T_{STG}$	-55 to 150	$^{\circ}C$
Operating Junction Temperature Range	$T_J$	-55 to 150	$^{\circ}C$

**Thermal Characteristics**

Parameter	Symbol	Typ	Max	Unit
Thermal Resistance Junction-Ambient <sup>1</sup>	$R_{\theta JA}$	---	36	$^{\circ}C/W$

**Electrical Characteristics ( $T_J=25^\circ\text{C}$ , unless otherwise noted)**

Parameter	Symbol	Conditions	Min	Typ	Max	Unit
Drain-Source Breakdown Voltage	$BV_{DSS}$	$V_{GS}=0V, I_D=-250\mu A$	-30	-33	---	V
Static Drain-Source On-Resistance <sup>2</sup>	$R_{DS(ON)}$	$V_{GS}=-10V, I_D=-15A$	---	5	7	m $\Omega$
Gate Threshold Voltage	$V_{GS(th)}$	$V_{GS}=V_{DS}, I_D=-250\mu A$	-1.0	-1.5	-2.5	V
Drain-Source Leakage Current	$I_{DSS}$	$V_{DS}=-30V, V_{GS}=0V, T_J=25^\circ\text{C}$	---	---	-1	$\mu A$
Gate-Source Leakage Current	$I_{GSS}$	$V_{GS}=\pm 20V, V_{DS}=0V$	---	---	$\pm 100$	nA
Forward Transconductance	$g_{fs}$	$V_{DS}=-10V, I_D=-15A$	30	---	---	S
Total Gate Charge	$Q_g$	$V_{DS}=-15V, V_{GS}=-10V, I_D=-10A$	---	65	---	nC
Gate-Source Charge	$Q_{gs}$		---	12	---	
Gate-Drain Charge	$Q_{gd}$		---	14	---	
Turn-On Delay Time	$T_{d(on)}$	$V_{DD}=-15V, V_{GS}=-10V, R_G=3\Omega, I_D=-10A$	---	20	---	ns
Rise Time	$T_r$		---	13	---	
Turn-Off Delay Time	$T_{d(off)}$		---	55	---	
Fall Time	$T_f$		---	21	---	
Input Capacitance	$C_{iss}$	$V_{DS}=-15V, V_{GS}=0V, f=1\text{MHz}$	---	3960	---	pF
Output Capacitance	$C_{oss}$		---	489	---	
Reverse Transfer Capacitance	$C_{rss}$		---	268	---	

**Drain-Source Diode Characteristics**

Parameter	Symbol	Conditions	Min	Typ	Max	Unit
Diode Forward Voltage <sup>2</sup>	$V_{SD}$	$V_{GS}=0V, I_S=-2A, T_J=25^\circ\text{C}$	---	---	-1.2	V

**Note:**

1. The data tested by surface mounted on a 1 inch<sup>2</sup> FR-4 board with 2OZ copper.
2. The data tested by pulsed, pulse width  $\leq 300\mu s$ , duty cycle  $\leq 2\%$
3. The power dissipation is limited by 150 $^\circ\text{C}$  junction temperature

**Typical Characteristics**

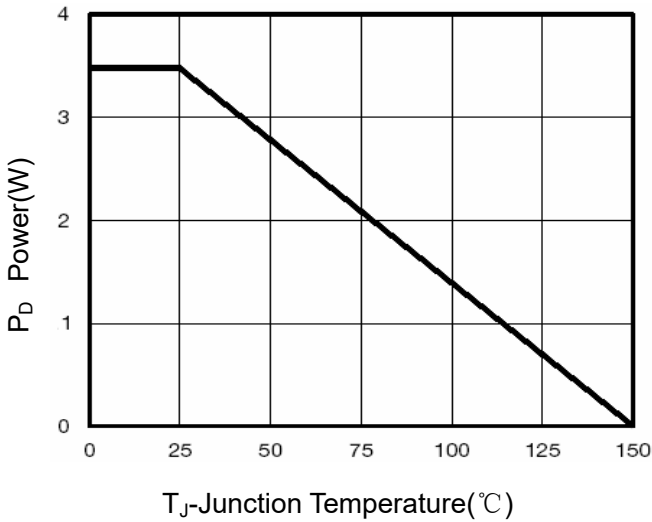

**Figure 1 Power Dissipation**

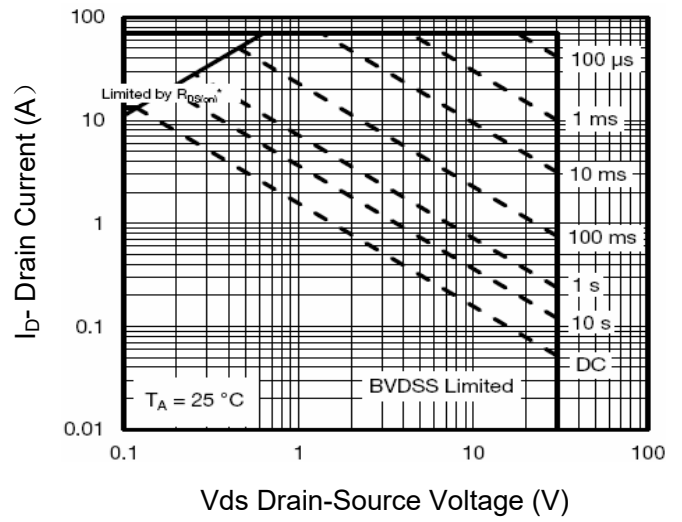

**Figure 2 Safe Operation Area**

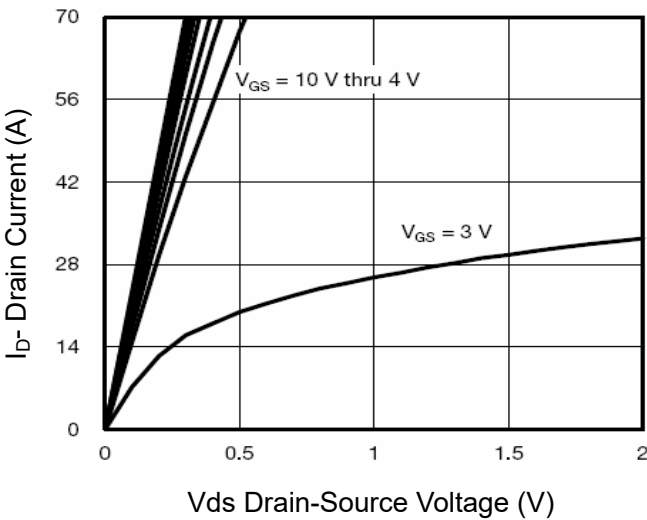

**Figure 3 Output Characteristics**

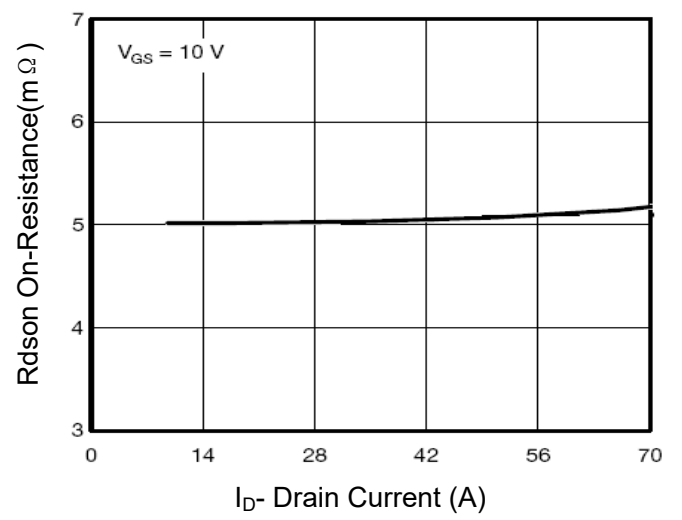

**Figure 4 Drain-Source On-Resistance**

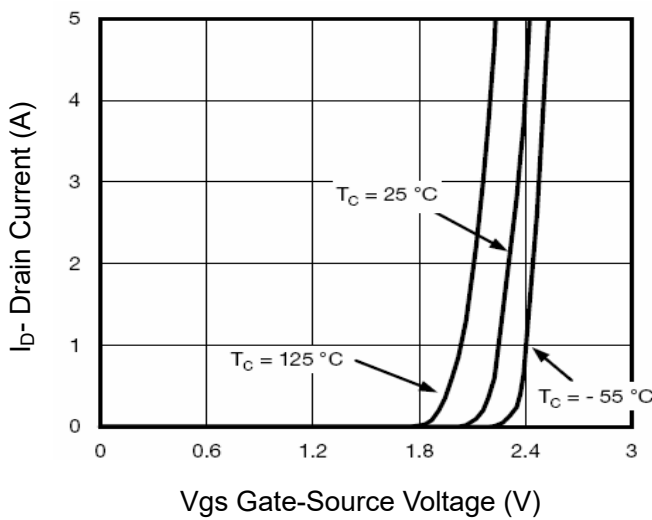

**Figure 5 Transfer Characteristics**

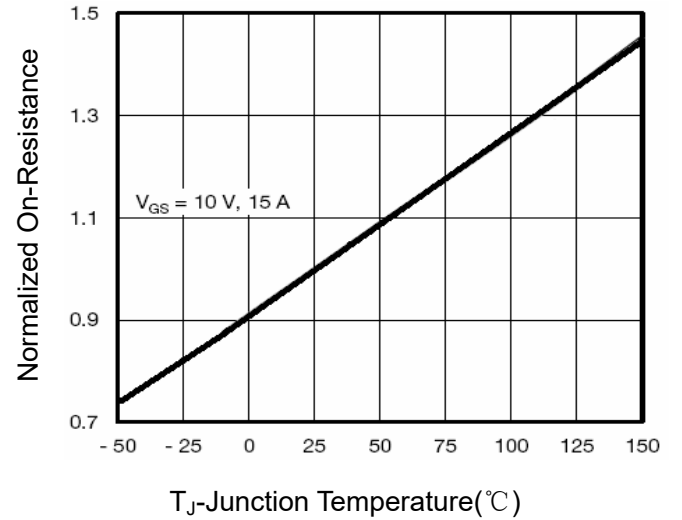

**Figure 6 Drain-Source On-Resistance**

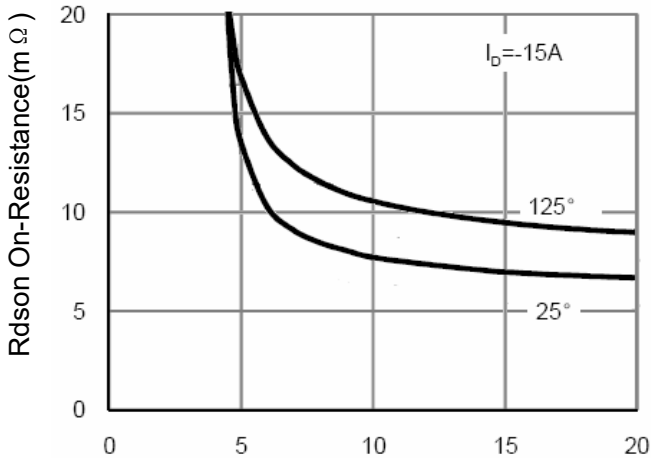

Vgs Gate-Source Voltage (V)  
**Figure 7 Rdson vs Vgs**

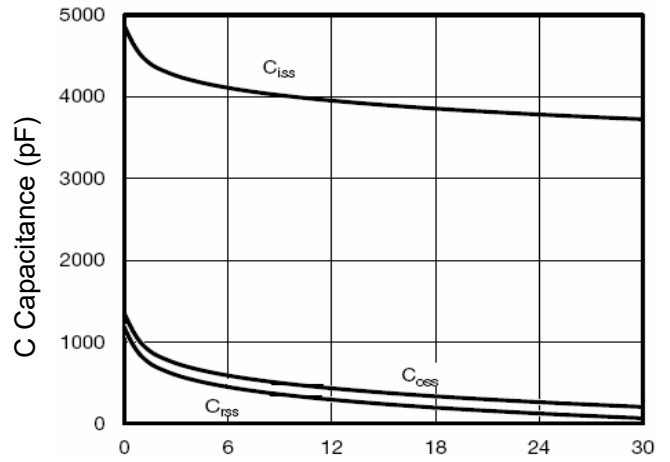

Vds Drain-Source Voltage (V)  
**Figure 8 Capacitance vs Vds**

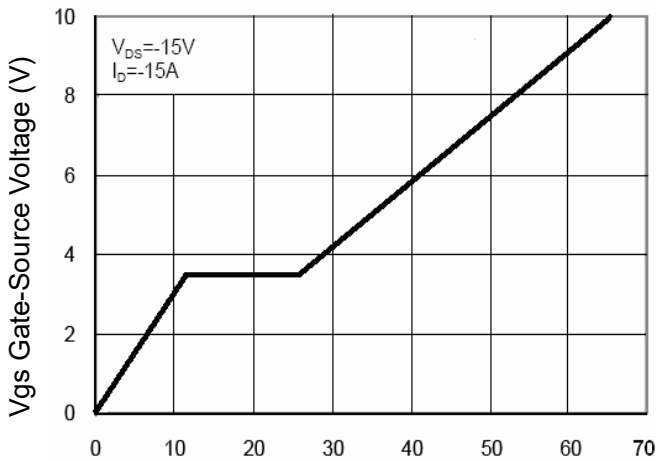

Qg Gate Charge (nC)  
**Figure 9 Gate Charge**

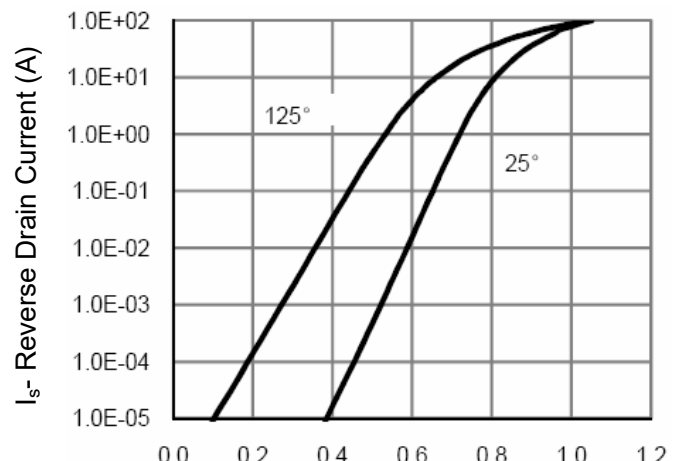

Vsd Source-Drain Voltage (V)  
**Figure 10 Source-Drain Diode Forward**

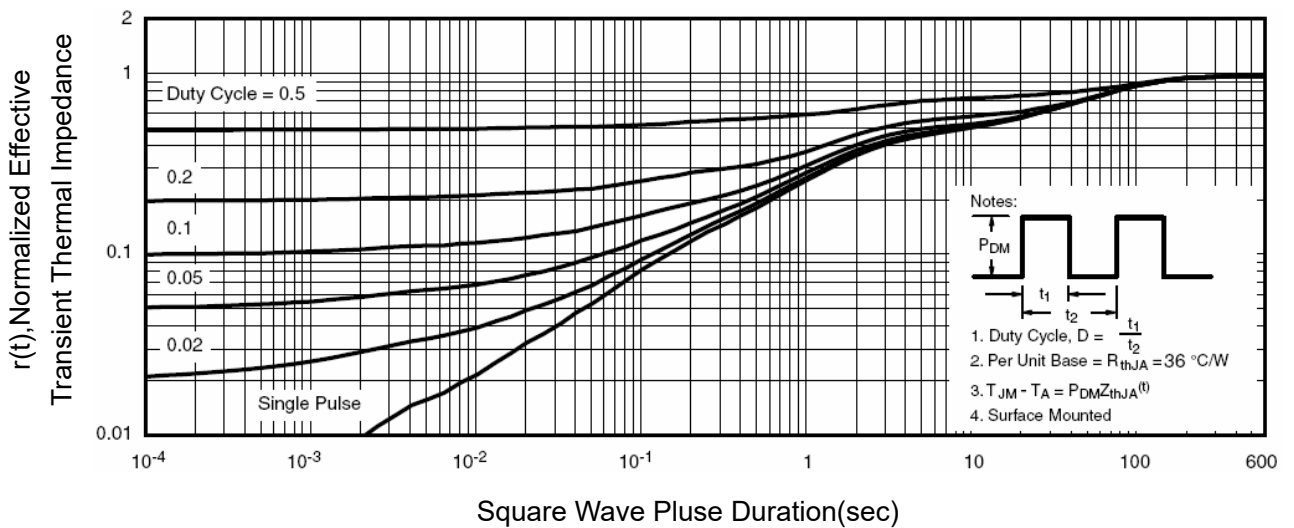

Square Wave Pluse Duration(sec)  
**Figure 11 Normalized Maximum Transient Thermal Impedance**

**SOP-8 Package Outline Dimensions**

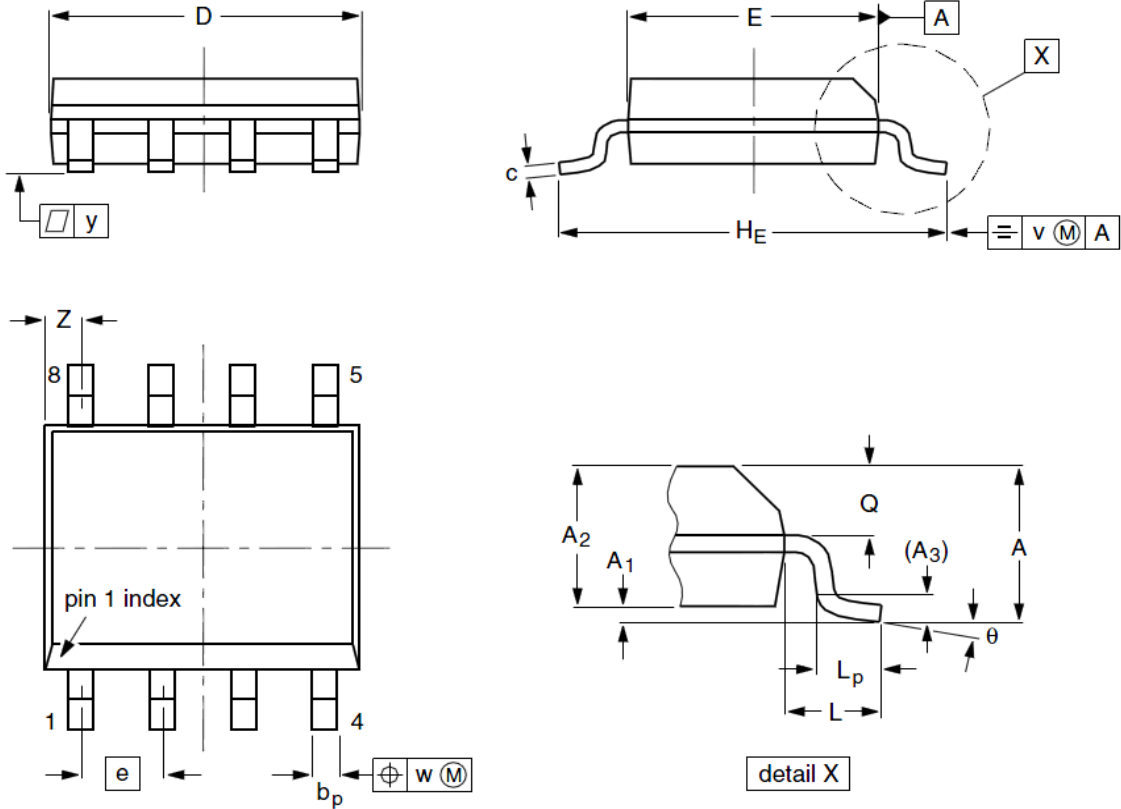

Symbol	Dimensions (unit:mm)			Symbol	Dimensions (unit:mm)		
	Min	Typ	Max		Min	Typ	Max
<b>A</b>	1.35	1.55	1.75	<b>A<sub>1</sub></b>	0.10	0.18	0.25
<b>A<sub>2</sub></b>	1.25	1.45	1.65	<b>A<sub>3</sub></b>	--	0.25	--
<b>b<sub>p</sub></b>	0.36	0.42	0.51	<b>c</b>	0.19	0.22	0.25
<b>D</b>	4.70	4.92	5.10	<b>E</b>	3.80	3.90	4.00
<b>e</b>	--	1.27	--	<b>H<sub>E</sub></b>	5.80	6.00	6.20
<b>L</b>	--	1.05	--	<b>L<sub>p</sub></b>	0.40	0.68	1.00
<b>Q</b>	0.60	0.65	0.73	<b>v</b>	--	0.25	--
<b>w</b>	--	0.25	--	<b>y</b>	--	0.10	--
<b>Z</b>	0.30	0.50	0.70	<b>θ</b>	0°		8°